

Design and Fabrication of Wind Energy Water Pump

MR. S. Saravanan¹, D. Anbazahan², G. S. Manikandan³, M. Mathavan⁴, A. Mohamed Afrith⁵, K. Prakash⁶

1,2. Assistant professor, Department of Mechanical Engineering, Gnanamani College of Technology

3,4,5,6 III year, BE, Department of Mechanical Engineering, Gnanamani College of Technology

Abstract: - In our project wind energy is used to rotate the wind blades. This blade coupled to the shaft. At the end of shaft the flywheel is placed. The eccentric arrangement is provided in the flywheel. When the blade rotates automatically fly wheel also rotates. Due to the eccentric arrangement the rotation motion of the flywheel is converted into linear motion. This reciprocating motion is given to the handle of the pumping system. The up down motion of the handle is given to the piston, where the water is sucked using pressure variation from lower ground. Finally the water is supplied to the outlet. Wind blade provides the continuous motion which helps to supply the water continuously. Since time immemorial, the main source of energy has been coal, oil, natural gas, nuclear energy, wood and coal. However, all these sources are limited and are the main cause of pollution and this has led to development and more focus on sustainable energy supply with minimum pollution effects. Hence research and analysis has shown that wind energy, solar energy and biomass are the most prominent solutions to the above problems because they are eco-friendly and readily available in nature.

Keywords: Fly wheel, Reciprocating pump, Blade, and etc....

INTRODUCTION:

Energy from the air can be utilized in multi various ways. It can be tapped directly from air in the form of electrical energy. The contribution of these sources in the total consumption of energy in the world is about 15%. The scope for application of air energy now stands inherently enhanced through intensive research and development carried out all over the world. Air can be directly utilized for the purpose of cooking and drying. By the same time, it can be also used for boiling of water, air heating and refrigeration. Furthermore wind energy can be utilized for driving motors for pollution free riding at this time, where air pollution plays a major problem for environmentalist

EXPERIMENTAL PROCEDURE :

The experimental analysis of this project started with a detailed study of various mechanisms that could be used in this project and their practical applications. Since this project involves the effective utilization of energy derived when a nature air the design aspects may not actually coincide with the requirements for the fabrication and practical applications. Hence, the method of **Reverse Engineering** was adopted in this project.

As per this method the tower was first fabricated based on the requirements with standard parts keeping in mind

various safety precautions. Testing and then the basic designing of the parts followed this. If any of the parts was found to possess strength lesser than the required, it was replaced by a standard part of greater strength. the wind energy is converted into mechanical energy. Initially this project had a nature air area and tower with a fly wheel leaf reciprocating pump arrangement. Also the rotation of the flywheel was not found to be satisfactory, reducing the efficiency of the leaf. This flywheel and leaf has a velocity ratio of 1:1. leaf is attached to the flywheel. Windmills generally consist of two basic types with the classification being based on the orientation of the axis of the rotor. The main classifications are discussed below



Fig.1 vertical wind plates

Vertical Axis Wind Turbine (VAWT)

This has blades which are arranged on the vertical axis and are rotated by wind and therefore it doesn't require a yaw mechanism since it can harness wind from any direction. It does not rely on the direction of the wind to generate power as in the case of the horizontal axis.

They usually operate closer to the ground which has an advantage of allowing for placement or replacement of heavy equipment. However this is a disadvantage as winds are lower near ground level hence less power output.

There are two main types of the VAWT namely:
Savonius

It operates like a water wheel which uses drag forces. It has a simple design and is therefore relatively simple and

cheaper to build. It is mostly used in situations that do not require large amounts of power. However, it is less powerful than most HAWT because it uses drag to rotate itself and has a higher power to weight ratio. The total amount of turning torque of the mechanism relies on the drag force on each blade.

Darrieus

It uses blades similar to those used in the horizontal axis wind turbine (HAWT). It has two or more curved blades that depend on wind in order to revolve around a central column. It functions by generating a lift using the rotating motion of the blades. The wind acting on the blade creates a rearward momentum change which propels the blade in the direction of rotation. This cannot occur unless the blades are already rotating and therefore they require a separate means of starting i.e. they are not self-starting.

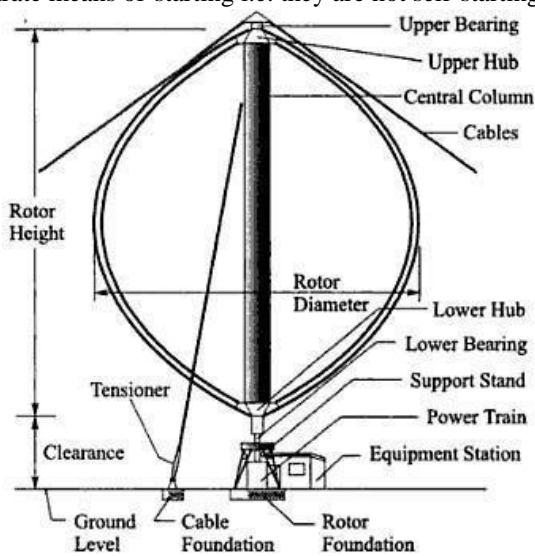

Fig.2 Vertical Axis Wind Turbine

Horizontal Axis Wind Turbine (HAWT)

It has blades that are similar in design to aircraft propellers where air flow over the airfoil shaped blades produces a lifting force that turns the rotor. They should be placed on towers to ensure maximum use of the winds at higher levels.

For large scale types, they have an active yaw mechanism with wind direction sensors and motors that will rotate the nacelle. In both upwind and downwind the rotors should be perpendicular to the direction of wind and if the rotor is held in a fixed position, only 21% of the wind energy will be captured (Wortman, 1983). For upwind type, the rotor rotation is accomplished by using a vane to measure the direction of the wind and then the information is communicated to the yaw drive. The yaw drive then drives the rotor so that the turbine is facing the direction of wind for maximum harness. They don't suffer from wind shade phenomenon as the wind is tapped early enough before obstruction by the tower. For downwind types, they don't use a yaw drive because the wind itself orients the turbine. The blades are situated on the downwind side and therefore capture the wind and rotate following its direction. These

designs are prone to "wind shade" a process in which the wind flow is obstructed by an object e.g. the tower thus reducing amount of wind and therefore a reduction in the power output

BEVEL GEARS:



Fig.3 Bevel gear

Bevel gears are used as the main mechanism for a hand drill. As the handle of the drill is turned in a vertical direction, the bevel gears change the rotation of the chuck to a horizontal rotation

PUMP:



Fig.4 pump

Hand pumps are manually operated pumps; they use human power and mechanical advantage to move fluids or air from one place to another. They are widely used in every country in the world for a variety of industrial, marine, irrigation and leisure activities.

SLIDER CRANK:

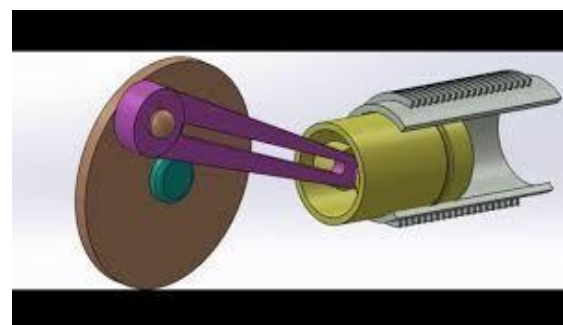

Fig.5 slider crank

A **crank** is an arm attached at a right angle to a rotating shaft by which **reciprocating motion** is imparted to or received from the shaft. It is used to convert **circular motion** into reciprocating motion, or vice versa. The arm may be a bent portion of the shaft, or a separate arm or disk attached to it. Attached to the end of the crank by a pivot is a rod, usually called a **connecting rod**. The end of the rod attached to the crank moves in a circular motion, while the other end is usually constrained to move in a **linear sliding motion**.

DESCRIPTION :

Field of the Invention

The present invention relates generally to the recovery of water from an underground source through the use of a reciprocating pump system. The present invention relates more specifically to an improved water pumping system adapted to be driven by a windmill that utilizes an air lift fluid pump for generating a flow of water to the surface

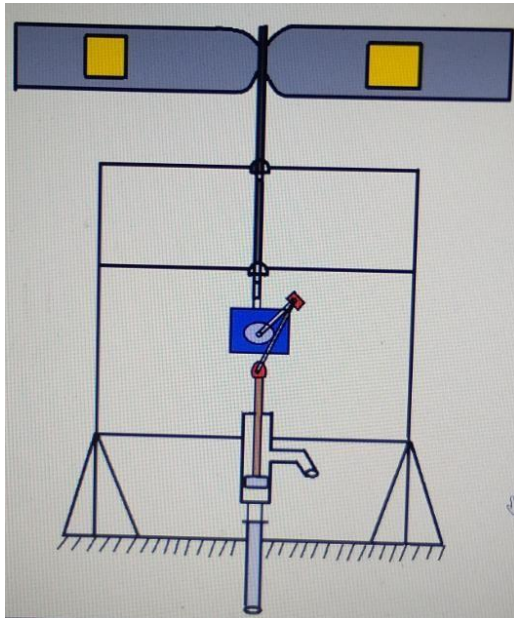

Fig.6 Block diagram

Description of the Related Art

Water pumping windmills may be found on farms and ranches worldwide and provide critical water supply for domestic and livestock use, especially in areas where electrical and fuel driven pumps are not practical. The type of technology associated with these windmill water pumps has enjoyed continuous use since the late 19th Century and may be generally illustrated by U.S. Pat. No. 1,632,188 assigned to the Dempster Mill Manufacturing Company (1927). This type of windmill pumps water by means of a positive displacement, reciprocating pump, submerged below the static water level of a drilled well. The pump is conventionally connected and supported by a water discharge pipe which leads to the surface and a reservoir for the water. The pump is driven by a reciprocating rod, typically made of wood or fiberglass, which reaches down from the windmill's transmission to

the pump through the discharge pipe.

It is typical in reciprocating water pumps of this type to utilize a barrel or cylinder within which a piston is moved in a reciprocating motion by the pump rod. Both the piston and the bottom of the pump barrel incorporate check valves that allow water to flow only in the upper direction. The check valve at the bottom of the cylinder is commonly called the foot valve, while the valve in the piston is commonly called the lift valve.

When the piston is lifted by the pump rod attached to the surface windmill, the lift valve closes and the piston lifts the entire column of water above it until water overflows out of the discharge pipe at the surface. At the same time a slight suction is formed under the piston causing the foot valve to open and water to flow in under the piston. During the next half of the cycle the piston moves down causing the foot valve to close and the lift valve to open such that water flows through the piston into a position to be lifted during the next half cycle.

Water flow valves, such as those described above, must be periodically replaced. The lift valve, which is typically made of leather or rubber, eventually wears due to particles of sand or earth in the water. Other check valves involved with the system also have finite useful lives and must be replaced on a regular basis. Replacement typically involves the removal of the pump rod, discharge pipe and pump by lifting the entire assembly up from the drilled well in order to access the valves. Such replacement efforts involve considerable labor and expense and greatly affect the down time of the windmill pumping system.

Obviously many efforts have been made in the past to replace the windmill pumping system powered by electrical motors and internal combustion engines. The present concern relates only to such efforts that have sought to improve upon wind driven pumping systems. One effort in the past is described in U.S. Pat. No. 3,367,281 issued to Gray on Feb. 6, 1968 entitled apparatus for pumping water from wells using wind power. The Gray patent discloses a water pumping device in which compressed air is generated by a windmill, stored in a tank, controlled through a pressure regulator, and delivered to a displacement type water pump. This invention, although not overly complex, is not directly adaptable to the typical windmill structure.

The Gray disclosure describes a down stroke of a windmill pump rod as the compression stroke which does not lend itself well to application in conjunction with typical windmills that are designed to apply force and power on the upstroke of the pump rod. The pump rod conventionally made of wood would likely snap if used to compress air on the down stroke. The Gray invention also utilizes solenoid valves that are electrically controlled to effectuate the air compression cycle. Such electrically controlled valves are typically not practical in remote windmill locations. Finally, the Gray invention further requires the use of an air hold-up means and a pressure regulator.

U.S. Pat. Nos. 4,385,871 and 4,358,250

provide further examples of inventions generally related to the conversion of wind energy into compressed air for the purpose of water pumping. These earlier efforts, however, also do not address an appropriate adaptation of the air

compressing mechanism to the typical windmill structure or to the utilization of the same in conjunction with an air injection type water pump.

SELECTION OF SITE TO WORKING:

The viability of a windmill is greatly affected by its location. The site must have sufficient wind power to move the windmill and also be away from obstructions that might cause turbulence. The speed of wind for a given location is not constant and thus the climatic condition of the site should be examined for over on a year and recorded on a wind map which is then used to analyze the suitability of the sit. To avoid distractions, most windmills are located on hilly areas or the rigs are tall enough to ensure the rotor is far above the obstacles. The site of our windmill had been identified and there was no need for selection of another site. However we did an analysis on the site to determine its suitability and the findings were as follows. The location of the windmill is strategically away from tall buildings and tree.

CONCLUSION:

The total torque output of the windmill is **106.4572 Nm** and this is sufficient to sustain the desired flow rate of **(0.1736 X 10⁻³) m³ per second** with a maximum head of **30m**, and also to overcome other barriers to 5motion e.g. friction. The number of blades used is **24** with a total surface area of **0.5585 m²** and this gives a solidity of **0.8**, the minimum (optimum) value of solidity for a windmill and therefore ensures conformity with the standard specifications. Gears and bearings are subject to very high heat losses due to friction and this will be greatly minimized by application of oil and grease and therefore greatly improving the efficiency. All materials used are locally available and at a low cost making the model economically viable.

REFERENCES

1. Wind Power Plants: Fundamentals, Design, Construction and Operation, R. Gasch, J. Twele, et al., Springer Verlag, 2012
2. Performance Test on Helical Savonius Rotor, S.B. Kedare, 2003.
3. Wind Power Fundamentals: Alex Kalmikov and Katherine Dykes With contributions from: Kathy Araujo PhD Candidates, MIT Mechanical Engineering, Engineering Systems and Urban Planning MIT Wind Energy Group &Renewable Energy Projects in Action
4. Wind pump handbook (pilot edition) prepared by S.K Tewari and R.P. Gupta, Tata Energy Research Institute, 1982.
5. Thermodynamic and Transport Properties of Fluids SI Units arranged by G. F. C. Rogers and Y. R. Mayhew Fifth Edition Blackwell Publishing, 1995, Oxford, U.K.
6. Water pumping design, NYANGASI, George Oduwo, 2012.
7. Kenya Wind Atlas, Kenya Meteorological Department, 2010.