

Design and Fabrication of Tesla Bladeless Turbine to Convert the Waste Pressure Energy into Electricity

Omkar Jigjini

Third Year Engineering Student

Mechanical Engineering Department

Dr. Vishwanath Karad MIT World Peace University
Pune, Maharashtra, India

Nikhil Karwa

Third Year Engineering Student

Mechanical Engineering Department

Dr. Vishwanath Karad MIT World Peace University
Pune, Maharashtra, India

Abstract— This paper focuses at design and analysis of bladeless turbine, Tesla turbine is also known as the boundary layer turbine, because it uses boundary layer effect and not a fluid impinging upon the blades as in a conventional turbine. Bioengineering researchers have referred to it as a multiple disk centrifugal pump. This Tesla turbine is a bladeless turbine which consists of disks instead of blades. This is a portable and efficient system which uses the waste pressure energy of exhaust gases/fluids to produce energy or electricity. Also the goal is to improve the efficiency of the turbine and get the best possible efficiency. Software like Auto-cad and Unigraphics Nx-8 were used to do modelling of the parts.

Keywords— Turbine, Bladeless, Disk, Boundary layer.

1. INTRODUCTION

Tesla Turbine consists of smooth disks, applies a moving fluid to the edge of the disk. The fluid flows on the disk with its velocity and adhesion of the surface layer of fluid. As fluid slows down its speed or becomes slow and adds energy to the disks, it spirals into the center exhaust. Since the rotor has no protrusion, it is very firm.

This Turbine can also be positively applied to condensing plants by using vacuum. In such case, with the great expansion ratio, the exhaust mixture will be at low temperature and suitable for admission to condenser. Better fuel has to be used and special pumping facilities to be provided. This construction allows the free expansion and contraction of each plate individually under the varying influence of heat and centrifugal force and contains various other advantages which are of considerable practical importance. Maximum active plate area and more power is obtained for a given width, improving efficiency. Disks are not rigidly fixed as they are protected against damage caused by vibration or excessive speed.

A Tesla Turbine is,

1. Able to start with steam alone.
2. A disk type adapted to work with fluids at high temperature.
3. Disks must be very thin to prevent drag and turbulence.

I. ABOUT THE PUMP

Similar set of disks and a housing with an involute shape, can be used as a pump. In pump a motor is attached to the shaft. The fluid enters near the center, and gets energy by the disks, then exits at the periphery. Tesla Turbine doesn't use friction in conventional sense instead it uses adhesion. It utilizes the boundary layer effect on the disk blades.

Smooth rotor disks were originally used, but they give poor starting torque.

Tesla turbine has not been widespread commercially use since its invention. However, the Tesla Pump has been commercially available since 1982 and is used to pump fluids that are abrasive, viscous, shear sensitive, contain solid, or are otherwise difficult to handle for other various pumps.

II. GOALS

1. Design of low-pressure turbine with electric generator to extract waste energy from gases and convert them into useful energy.
2. Design of low-cost solution to energy generation problem.

III. LITERATURE SURVEY

The industrial sector consumes 1/3 of the total energy in the world and is responsible for 1/3 of the fossil fuel related to greenhouse gas emissions. According to current estimates somewhere between 20 to 50% of the total energy input is lost in the form of waste pressure energy and pressure energy of exhaust gases. Continuous efforts of the industrial sector to improve its energy efficiency and to recover waste pressure energy losses lucrative opportunity for developing an emission free and less costly energy resource.

This paper aims to study various sources of waste pressure energy and pressure energy and recognize the effectiveness of a counter flow vortex tube applied to recover the waste energy. This technique is to enhance economic feasibility and increase recovery efficiency of waste pressure. A bottom-up perspective is used to investigate quantity and quality of waste energy, recovery methods and complications in path of improving their efficiency. The results from this investigation help to understand the state of waste pressure energy and

pressure energy and recommend re-design of energy recovery mechanisms.

IV. POWER RECOVERY TURBINES FOR ENERGY RECOVERY

There are applications in process industry where, the processing of a fluid stream (gas/air) requires its pressure to be reduced. This pressure reduction is usually accomplished through use of a throttling valve.

This paper includes the design and development of a bladeless turbine, decrease in the weight of the energy generating mechanism is the major factor driving towards the global bladeless wind turbines market. As bladeless wind turbines fluctuate when responding to vortices, the risk of bulky/heavy structural damage is comparatively low. Moreover, as bladeless wind turbines contain few parts, they emit less noise and also pose no harm/threat to birds.

The inclusion of fewer moving parts also makes construction of bladeless wind turbines more reliable than the conventional ones. They are also less expensive as compared to the traditional ones and are also easy to install.

V. PRINCIPLE OF OPERATION

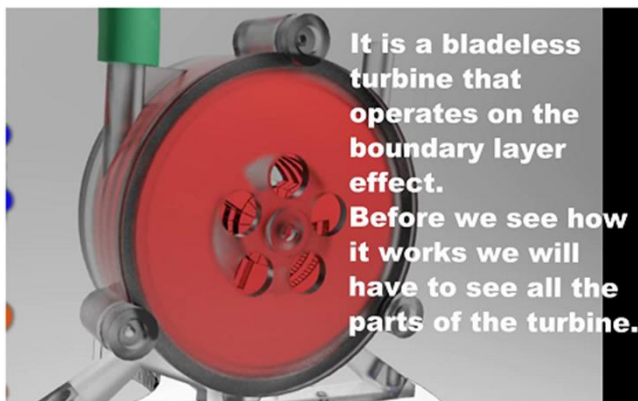

A. Step wise construction and working of Tesla Turbine

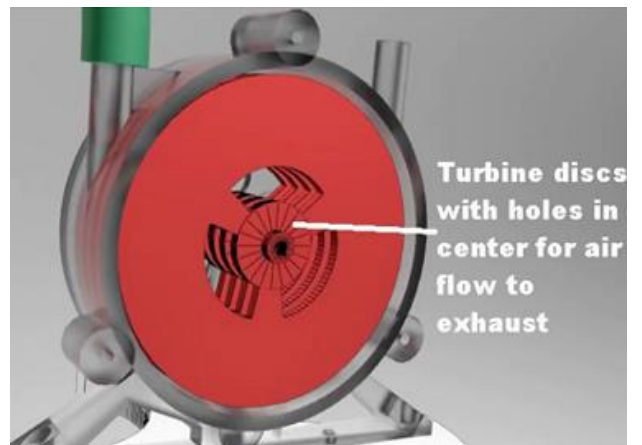
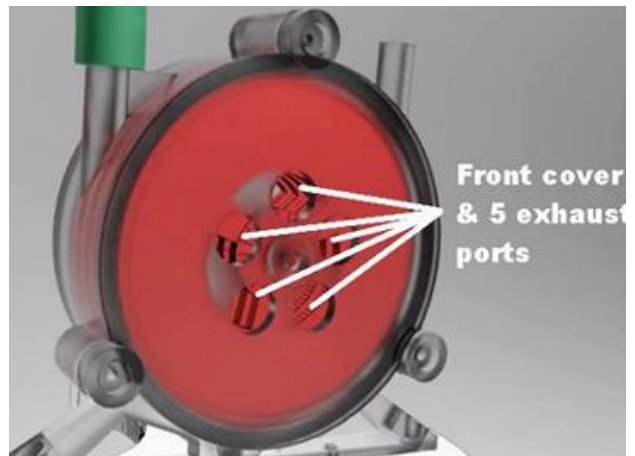
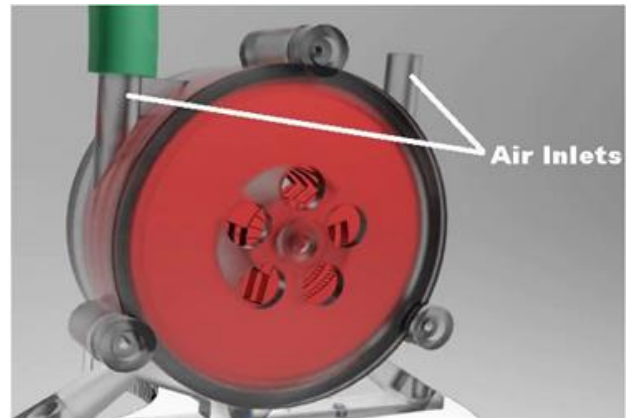

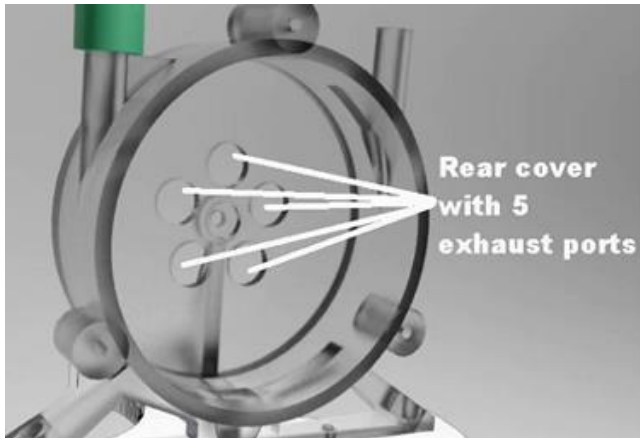

Rear cover with 5 exhaust ports

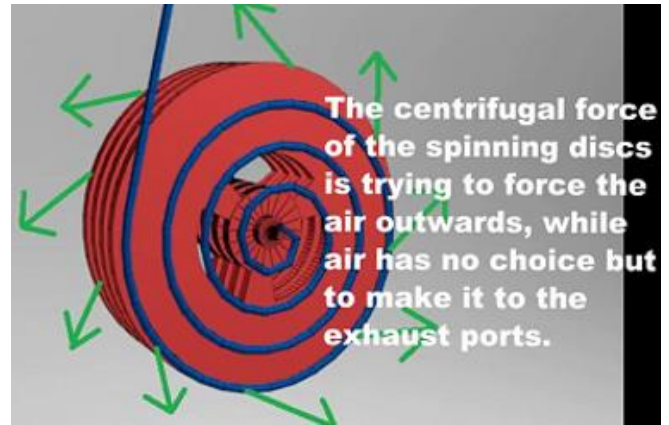

The centrifugal force of the spinning discs is trying to force the air outwards, while air has no choice but to make it to the exhaust ports.

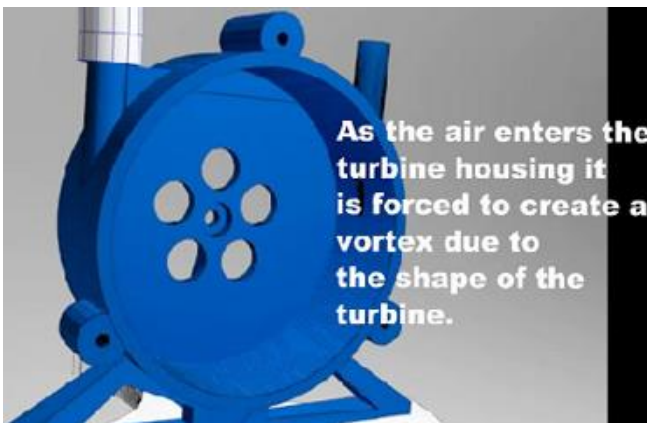

As the air enters the turbine housing it is forced to create a vortex due to the shape of the turbine.

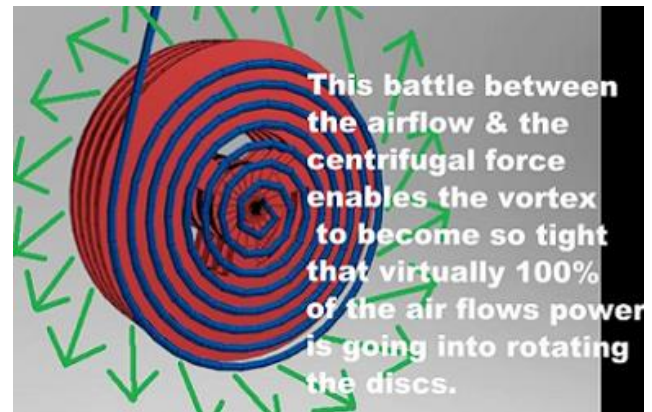

This battle between the airflow & the centrifugal force enables the vortex to become so tight that virtually 100% of the air flow's power is going into rotating the discs.



Remember that the front cover would also be in place so the air has no choice but to exit through the front or rear exhaust ports.

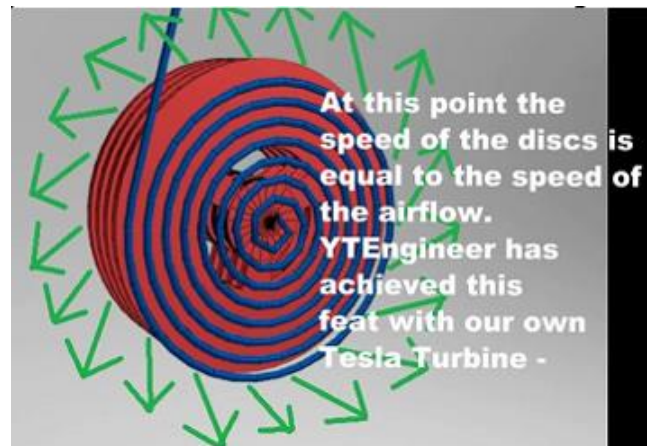

At this point the speed of the discs is equal to the speed of the airflow. YTEngineer has achieved this feat with our own Tesla Turbine -

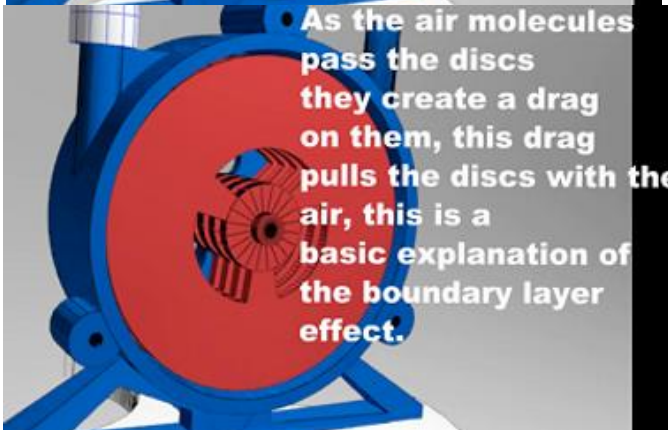

As the air molecules pass the discs they create a drag on them, this drag pulls the discs with the air, this is a basic explanation of the boundary layer effect.

VI. RISK MANAGEMENT

The project work is focused towards development of a low-pressure turbine that will operate at 2.5 bar to 6 bar pressure so the following risk management techniques may apply:

- a) To avoid excessive pressure above 10 bar
- b) Excessive flow rate will unnecessarily increase the turbine speed, resulting into failure of generator.
- c) Avoid high temperature gases as it may damage the bearings and seals.

A. Constraints

- 1. Turbine cannot handle high pressure.
- 2. Turbine cannot handle high temperatures.

3. Turbine cannot handle very high speeds.

B. Experimental setup-



VII. CALCULATIONS OF SYSTEM POWER

A- *Pressure Gas Power:* A positive displacement pneumatic motor can be ideally represented (case without truncating the intake) by a piston in an infinitely long cylinder, in which case the power is proportional to the product of the pressure time the flow.

Power (HP) = Pressure (psi) X Flow (cfm) / 229
 (As an example: 1 HP = 10 cfm at 22.9 psi)
 or (1 m3 / min = 35.3 cfm):
 Power (kW) = Pressure (bar) X Flow (m3/min) X 1.70
 (As an example: 1 kW = 0.294 m3/min at 2 bar)

If the intake pressure increases, the flow (rpm) increases also, such that generally the engine power increases as the square of the pressure.

Remember there may be a significant difference between the pressure applied at the engine intake and the actual pressure into the engine chambers. Furthermore, no engine is 100 % efficient.

B- *Minimum Input Conditions:* In our case the **minimum pressure and flow conditions are:**

Pressure (min) = 2 bar
 Flow min = 1.2 cfm = 0.034 m3/min
 Power (min) ((kW) = Pressure (bar) X Flow (m3/min) X 1.70
 = 2 x 0.034 x 1.70 = 0.115 Kw = 115 watt.
 Hence minimum power output from engine for given input conditions = 115watt

C- *Maximum Input Conditions:* In our case the **maximum pressure and flow conditions are:**

Pressure (min) = 5bar
 Flow min = 1.8 cfm = 0.050 m3/min
 Power (min) ((kW) = Pressure (bar) X Flow (m3/min) X 1.70
 = 5x 0.05 x 1.70 = 0.425 Kw = 425 watt.
 Hence minimum power output from engine for given input conditions = 425 watt

D- *Torque Analysis:* Torque at spindle is given by;

$$T_s = \frac{975 N}{n}$$

where;

$$T_s = \text{Torque at spindle (kg.m)}$$

$$N = \text{POWER (Kw)}$$

$$n = \text{Speed (rpm)}$$

Maximum power output = 425 watt at 8000 rpm

$$\Rightarrow T_s = \frac{975 \times 0.425}{8000}$$

$$T_s = 0.0517 \text{ kg .m}$$

$$\Rightarrow T_s = 0.508 \text{ N.m}$$

Considering 100 % overload;

$$T_{\text{design}} = 2 T_s$$

$$= 1.016 \text{ N-m}$$

$$= 1.016 \text{ N.m}$$

$$\Rightarrow T_{\text{design}} = 1.016 \text{ N.m}$$

$$T_{\text{Design}} = 1.016 \text{ Nm.}$$

E- *Design of Main Shaft-*

Selection of main shaft material

Table 1-

Designation	Ultimate Tensile Strength N/mm ²	Yield strength N/mm ²
EN 24 (40 N; 2 cr 1 Mo 28)	720	600

Using ASME code of design;

Allowable shear stress;

$f_{s_{all}}$ is given stress;

$$f_{s_{all}} = 0.30 \text{ syt} = 0.30 \times 600 = 180 \text{ N/mm}^2$$

$$f_{s_{all}} = 0.18 \times \text{Sult} = 0.18 \times 720 = 130 \text{ N/mm}$$

Considering minimum of the above values;

$$f_{s_{all}} = 130 \text{ N/mm}^2$$

As we are providing DIMPLE on shaft;

Reducing above value by 25%.

$$\Rightarrow f_{s_{all}} = 0.75 \times 130 = 97.5 \text{ N/mm}^2$$

a) Considering pure torsional load;

Minimum section on the spindle as per system drawing is 8mm.

$$T T_{\text{design}} = \frac{\pi}{16} f_{s_{act}} d^3$$

$$f_{s_{act}} = \frac{16 \times T}{\pi \times d^3}$$

$$f_s_{act} = \frac{16 \times 1.016 \times 10^3}{\pi \times 8^3}$$

$$f_s_{act} = 10.2 \text{ N/mm}^2$$

As $f_s_{act} < f_s_{all}$

Spindle is safe under pure torsional load.

F- Design of Gear Pair-1: GEAR PAIR DETAILS

Table 2.1- SUN GEAR

MODULE	1
NO OF TEETH	40
ADDENDUM DIAMETER	42
PITCH CIRCLE DIAMETER	40

Table 2.2-PLANET GEAR

MODULE	1 mm
NO OF TEETH	60
ADDENDUM DIAMETER	62
PITCH CIRCLE DIAMETER	60

Material of gears =Nylon 66

Sultimate = 240 N/mm²

The tangential tooth load on the input gear = 1.016 x 10³/(40/2) = 50.8 N

Sultpinion = Sult gear = 240N/mm²

Service factor (Cs) = 1.5

$$\Rightarrow P_t = 50.8 \text{ N.}$$

P efficiency is given as:

$$\left(\frac{P_t \times C}{C_v} \right) = \left(\frac{50.8 \times 1.5}{C_v} \right) \quad 1.5$$

Now,

$$C_v = \frac{3}{3 + v}$$

$$v = \pi DN = \frac{\pi \times 40 \times 10^{-3} \times 8000}{60}$$

$$= 16.7 \text{ m/sec}$$

$$\Rightarrow C_v = 0.15$$

$$P_{eff} = \left[\frac{225.6 \times 1.5 \times 1.5}{0.56} \right]$$

$$P_{eff} = \left[\frac{76}{\quad} \right] \text{ ----(A)}$$

Lewis Strength equation

WT = S_{bym}

Where;

$$Y = 0.484 - 2.86Z$$

$$\Rightarrow y_p = 0.484 - \frac{2.86}{40}$$

$$= 0.4125$$

$$\Rightarrow S_{yp} = 99$$

$$W_T = (S_{yp}) \times b \times m$$

$$= 99 \times 10 \text{ m} \times m$$

$$W_T = 990 \text{ m}^2 \text{ -----(B)}$$

Equation (A) & (B)

$$990 \text{ m}^2 = 762$$

$$\Rightarrow m = 0.87$$

selecting standard module = 1 mm.

G- Selection of Main spindle Bearing -I

Selection of Bearing (6003ZZ)

We will use ball bearings for our application.

Selecting; Single Row deep groove ball bearing as follows.

Series 60

Table-3.1 SKF Bearing Designation-

IsI No	Bearing of basic Design No (SKF)	d	D1	D	D ₂	B	Basic capacity	
20AC03	6003	17	19	35	33	10	2850	4650

$$P = X F_r + Y F_a$$

For our application $F_a = 0$

$$\Rightarrow P = X F_r + Y F_a$$

As; $F_a / F_r < e \Rightarrow X = Y = 1$

$$\Rightarrow P = F_r = 50.8$$

Max radial load = $F_r = 50.8 \text{ N.}$

$$\Rightarrow P = 50.8 \text{ N}$$

Calculation dynamic load capacity of bearing

$$L = \frac{(C)^p}{P}$$

where p= 3 for ball bearings

When P for ball bearing

For m/c used for eight hours of service per day;

$$L_H = 12000 - 20000 \text{ hr}$$

$$\text{But; } L = \frac{60 n L_H}{10^6}$$

$$L = 240 \text{ mm}$$

$$\text{Now; } 240 = \frac{(C)^3}{50.8}$$

$$\Rightarrow C = 315.6 \text{ N.}$$

\Rightarrow As the required dynamic capacity of bearing is less than the rated dynamic capacity of bearing;

H- Selection of Main spindle Bearing -2

Selection of Bearing (6002ZZ)

We will use ball bearings for our application.

Selecting; Single Row deep groove ball bearing as follows.

Series 60

Table 3.2 SKF Bearing Designation-

ISI No	Bearing of basic Design No (SKF)	d	D1	D	D ₂	B	Basic capacity
15AC02	6002	15	17	32	30	9	2550 4400

$$P = X F_r + Y F_a$$

For our application $F_a = 0$

$$\Rightarrow P = X F_r + Y F_a$$

As; $F_a / F_r < e \Rightarrow X = Y = 1$

$$\Rightarrow P = F_r = 50.8$$

Max radial load = $F_r = 50.8$ N.

$$\Rightarrow P = 50.8$$

Calculation dynamic load capacity of bearing

$$L = \frac{(C)^p}{P}$$

where $p = 3$ for ball bearings

When P for ball bearing

For m/c used for eight hours of service per day;

$$L_H = 12000 - 20000 \text{ hr}$$

$$\text{But; } \frac{L - 60 n L_H}{10^6}$$

$$L = 240 \text{ mm}$$

$$\text{Now; } 240 = \frac{(C)^3}{50.8}$$

$$\Rightarrow C = 315.6 \text{ N.}$$

\Rightarrow As the required dynamic capacity of bearing is less than the rated dynamic capacity of bearing.

I- Design of Planet Gears:

MATERIAL SELECTION:

Table-4

DESIGNATION	TEXTILE STRENGTH N/mm ²	YEILD STRENGTH N/mm ²
EN 24	800	680

PLANET GEAR PINS are located in three holes on carrier disk at an PCD of 100 mm. These pins engage in the ball bearings placed in the transmission links and act as transmission elements.

'Three pins' transmit the entire torque;
 These pins are located at PCD (D_p) = 100mm

$$\text{Tangential force on each bolt } (F_b) = \frac{T}{D_p \times n}$$

Now;

$$\text{Shear stress} = \frac{\text{Shear force}}{\text{Shear area}}$$

$$f_{s_{act}} = \frac{F_b}{\frac{\pi}{4} \times d^2}$$

$$\Rightarrow F_b = f_{s_{act}} \times \frac{\pi}{4} d^2$$

$$T = n \times \frac{(f_{s_{act}} \times \pi \times d^2)}{4} \times \frac{D_p}{2}$$

Assuming Pin diameter = 6 mm, as planet gear id is 6mm

$$1.016 \times 10^3 = 2 \times \frac{(f_{s_{act}} \times \pi \times 6^2)}{4} \times \frac{100}{2}$$

$$\Rightarrow f_{s_{act}} = 0.717 \text{ N/mm}^2$$

As, $f_{s_{act}} < f_{s_{all}}$

\Rightarrow Pins are safe under shear load.

VIII. CAD DIAGRAMS:

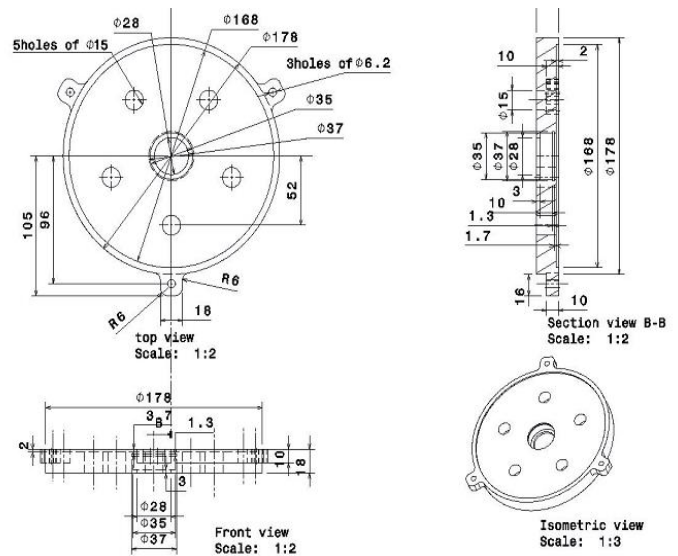

A- TURBINE DISK-

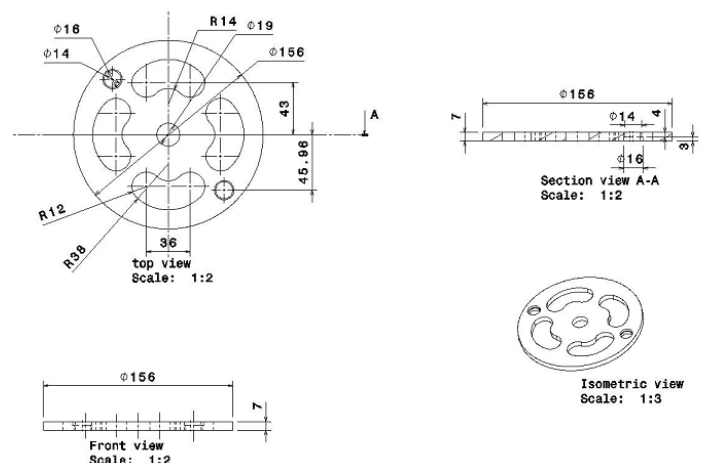

B- STRUCTURE-

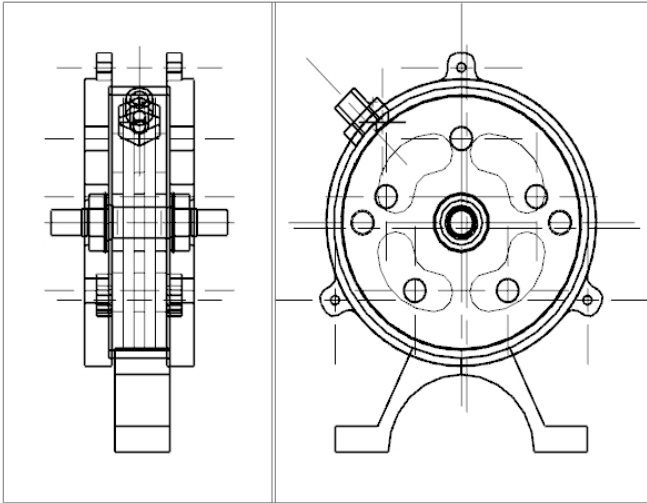

D- FRONT COVER-

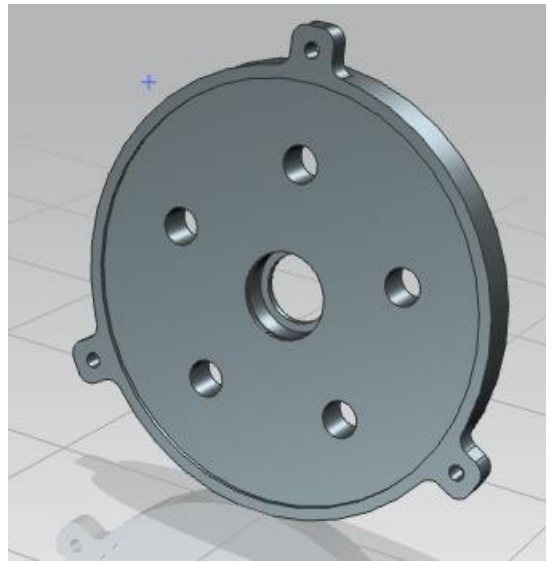
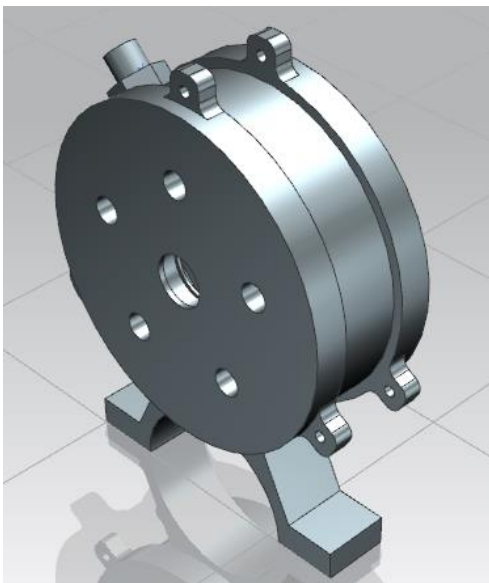
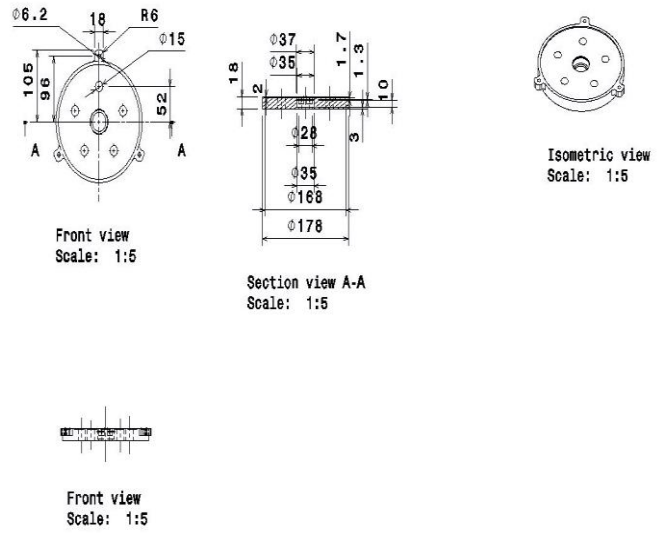

C- MAIN SHAFT-

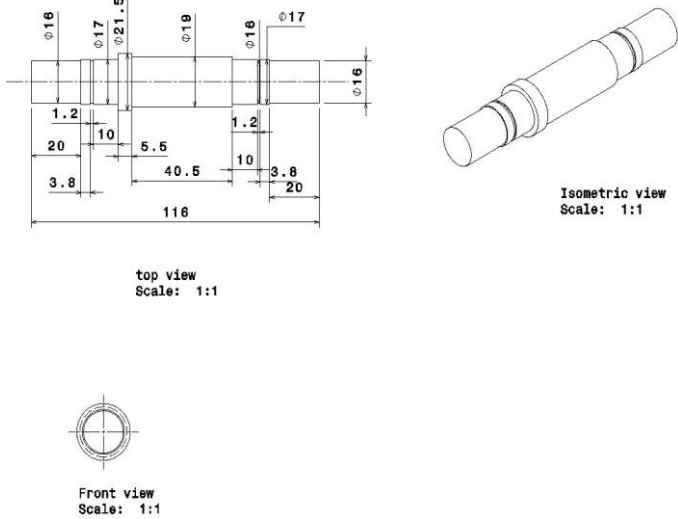

E- DISC PLATE-

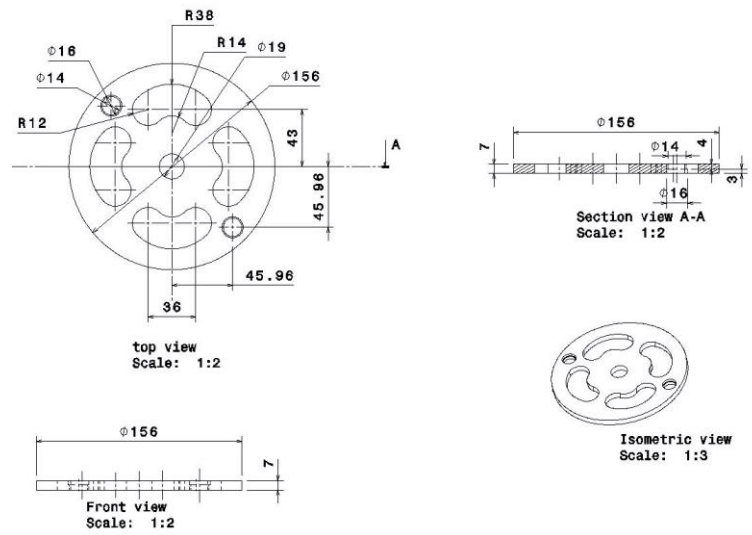

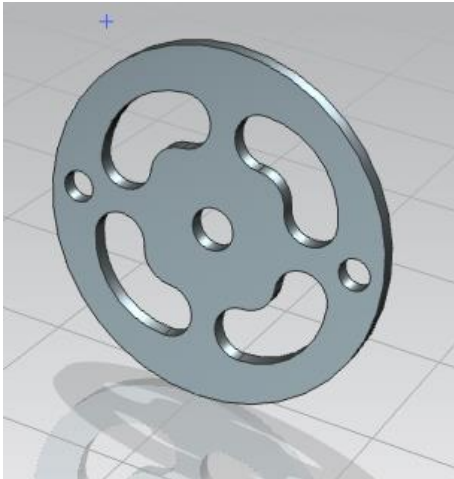

IX-CONCLUSION-

Low pressure bladeless turbine is conceived after careful literature review and literature gap being that there is absence of any such low-pressure energy recovery device. Casting process was selected as manufacturing process so as to produce the turbine in lowest possible cost, and make it operatable at various low pressures. 3-D modelling of parts

was done using Unigraphics Nx-8, Auto-cad and drafting was done to prepare working drawings. Testing was done to find power produced at various input pressure.

REFERENCES-

- [1] Nikola Tesla, "Fluid Propulsion" (Nikola Tesla Original patent), Pub. No.: US 1913/1,061.
- [2] W. Rice, "An Analytical and Experimental Investigation of Multiple Disk Turbines," *Journal of Engineering for Power*, vol. 87, pp. 29-36, 1965.
- [3] Bloudiček P. Design of Tesla turbine. In: *Theses conference*. Brno (Czech Republic): Institute of Solid Mechanics, Mechatronics and Biomechanics; 2007.
- [4] Thawichsri K and Nilnont W. A study on performance comparison of two-size Tesla turbines application in organic Rankine cycle machine. *Int J Adv Cult Tech* 2015; 3: 67–76.
- [5] Armstrong JH. An investigation of the performance of a modified Tesla turbine. Master's Thesis, Georgia Institute of Technology, Atlanta, GA, 1952.
- [6] Schosser C, Pfitzner M. A numerical study of the three-dimensional incompressible rotor airflow within a Tesla turbine. In: *Conference on modelling fluid flow (CMFF'15)*; 2015.
- [7] D. R. F. V. Jan Peirs, "A microturbine for electric power generation," *Sensors and Actuators A*, vol. 113, pp. 86-93, 2004.
- [8] Bao G, Shi Y, Cai N. Numerical modelling research on the boundary layer turbine using organic working fluid. In: *Proceeding of international conference on power engineering (ICOPE-13)*. Wuhan (China), 2013.