

# Design and Development of Condenser Coil Bending Machine

Smit S. Makani<sup>1</sup>, Prince G. Goti<sup>2</sup>, Yash D. Desai<sup>3</sup>, Shivam N. Sain<sup>4</sup>, Soham N. Miske<sup>5</sup>, Sandeep S. Patil<sup>6</sup>  
<sup>1,2,3,4,5</sup> Student (6<sup>th</sup> Semester- Mechanical Engg. Dept.) Tapi Diploma Engg. College, Surat, Gujarat, India-395006  
<sup>6</sup>Lecturer (Mechanical Engg. Dept.) Tapi Diploma Engg. College, Surat, Gujarat, India-395006

**Abstract - In the manufacturing of condenser coils, dimensions are extremely crucial because they directly affect the performance and efficiency of the condenser. During visits to several small-scale industries, we observed a major issue in the coil bending process. Multiple workers were assigned to perform the single task of condenser coil bending manually. This practice was highly inefficient, as it required more manpower and still failed to provide accurate and uniform bending. Since the bending was done manually, the coils often lacked precision and consistency, which could negatively impact the overall performance of the condenser.**

**To overcome these problems, this project focuses on the development of a Condenser Coil Bending Machine that is affordable, efficient, and specifically designed for this application. The machine aims to reduce manual labor, improve bending accuracy, ensure uniformity in coil dimensions, and increase productivity while remaining cost-effective for small-scale industries.**

**Key Words:** Manual Coil Bending Machine, Table height adjustment mechanism, Powerless Solution, Mechanical Design

## 1. INTRODUCTION

Condensers are widely used in refrigeration and air-conditioning systems, where the accuracy of condenser coil dimensions plays a crucial role in overall system performance. In many small-scale industries, condenser coil bending is still carried out manually, which often results in poor precision, uneven bends, higher labor requirements, and safety risks for workers.

To overcome these limitations, this project focuses on the design and development of a low-cost condenser coil bending machine specifically for small-scale industries. The proposed machine is designed to provide accurate and uniform bending while reducing manpower, production time, and material wastage. The machine consists of a simple mechanical setup including a roller, locking mechanism, and movable plank for efficient coil bending.

The developed system improves bending accuracy, enhances worker safety, and offers an economical alternative to expensive industrial machines. Experimental testing showed improved precision and reduced labor dependency, making the machine suitable for practical industrial applications.

## 2. LITERATURE REVIEW

### 2.1 “Automatic Serpentine Tube Bending Machine”: [1]

The paper details the design or development of an automated machine. This machine bends tubes into serpentine shapes. Serpentine tubes are winding, continuous S-shaped curves. They are commonly used in heat exchangers, radiators, and refrigeration cooling coils. Automation improves bending accuracy, reduces human error, and increases production speed compared to manual bending methods

### 2.2 “Homogeneous charge compression ignition combustion: Advantages and challenges”: [2]

This research paper includes detailed information about analysed combustion and thermal systems, highlighting the importance of heat transfer components such as condensers. Studies on gear motor optimization.

### 2.3 “Analysis of Roller Mechanism in Tube and Pipe Bending Machines”: [3]

This paper analyzes the function of rollers in pipe and tube bending machines. The researchers studied the effect of roller diameter and material on bend quality and surface finish. Results showed that proper roller design reduces deformation and improves bending accuracy. This paper helped in understanding the PVC roller design used in the condenser coil bending machine.

### 2.4 “Design and Fabrication of Pipe Bending Machine”: [4]

This paper explains the design and fabrication of a manually operated pipe bending machine used for industrial applications. The researchers focused on reducing human effort and improving bending accuracy. Different machine components such as rollers, frame structure, and bending handles were analysed. The study showed that a properly designed bending mechanism can improve productivity and reduce pipe damage during operation. This paper helped in understanding the basic working principle of manual bending systems.

## 2.5 “Development of a Low-Cost Tube Bending Machine for Small Scale Industries”: [5]

The paper presents the development of an economical tube bending machine specially designed for small-scale industries. The authors emphasized low manufacturing cost, easy operation, and reduced labor requirements. The machine was capable of producing accurate bends with less material wastage. This research is closely related to the present project because it also focuses on affordability and industrial usability.

## 2.6 “Design and Structural Analysis of Mechanical Bending Machine Using SOLIDWORKS”: [6]

The authors designed a bending machine using SOLIDWORKS software and carried out structural analysis of machine components. Stress analysis and load-bearing capacity of the machine were studied to ensure durability and safe operation. The paper demonstrated how virtual modelling and simulation help reduce design errors before fabrication. This research was useful during the design stage of the condenser coil bending machine.

## 2.7 “Design of Adjustable Height Worktable Mechanism Using Mechanical Locking System”: [7]

This paper explains the design of an adjustable height mechanism using locking pins, sprockets, and manual lifting arrangements. The mechanism was designed to improve operator comfort and machine flexibility. The study focused on stability, ease of operation, and safety during adjustment. This paper was useful for understanding the table height adjustment mechanism used in the condenser coil bending machine.

## 2.8 “Comparative Study of Mild Steel and Aluminium for Machine Frame Applications”: [8]

This paper compares mild steel and aluminum materials used in machine frames based on strength, cost, and fabrication properties. The results showed that mild steel provides better rigidity and lower cost for heavy-duty applications. The paper justified the use of M.S. pipes for machine fabrication in industrial applications.

## 2.9 “Material Selection in Mechanical Design Using Ashby’s Approach”: [9]

This reference explains systematic methods for selecting materials in mechanical design applications. Properties such as strength, hardness, corrosion resistance, cost, and manufacturability were analysed for different engineering materials. The study provides guidelines for selecting suitable materials for machine components. This reference was helpful in selecting M.S. pipes, PVC rollers, GI sheets, and steel rods for the project.

## 3. DESIGN

### 3.1 3D design of machine

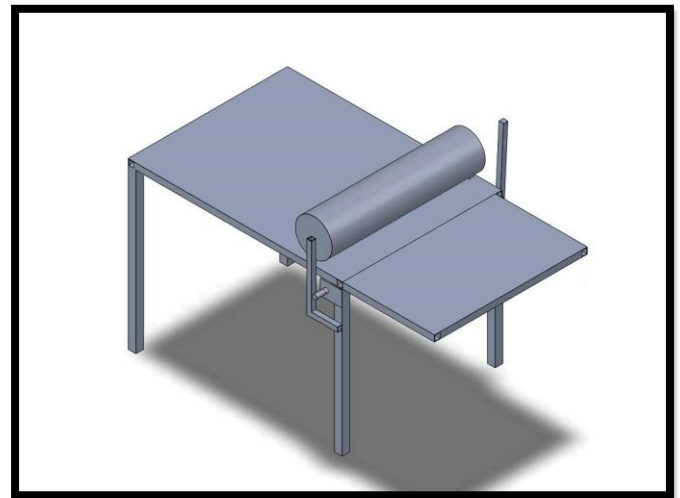

Fig -1: 3D Design

### 3.2 Table (upper body)

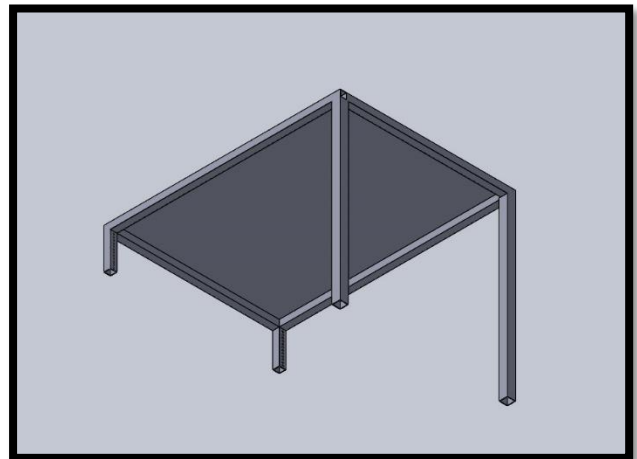

Fig -2: 3D design of Table (upper body)

The upper body of the machine acts as the primary structural framework on which all the major mechanisms and components are mounted. It is fabricated using Mild Steel (M.S.) square pipes with a Galvanized Iron (G.I.) sheet fixed on the top surface to provide rigidity and a smooth working platform. The rear legs of the frame are fixed, while the front legs contain holes for the sprocket-based height adjustment mechanism. The frame is designed to withstand operational loads during the bending process and maintain dimensional stability.

#### Functions:

Supports the complete machine structure.  
Holds the roller, moving plank, and locking mechanism.

Provides a stable working surface for positioning condenser coils.

**Specifications:**

Material: Mild Steel square pipe and G.I. sheet  
Dimensions: Length = 35 inches, Width = 25 inches, Height = 25 inches  
G.I. Sheet Thickness: 24 gauge  
Hole Diameter on Front Legs: 6 mm  
Hole Spacing: 10 mm

**3.3 Table (lower body)**

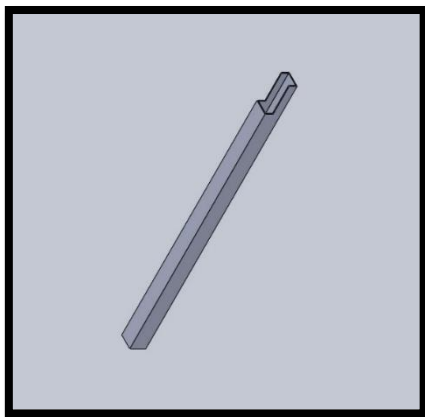

**Fig -3:** 3D design of Table (lower body)

The lower body is the supporting section of the machine that enables vertical movement of the upper frame for coil locking and height adjustment. It consists of larger diameter M.S. pipes into which the upper body legs slide smoothly.

**Functions:**

Supports the upper body.  
Allows height adjustment of the working table.  
Acts as a base for the locking mechanism and handle assembly.

**Specifications:**

Material: Mild Steel Pipe  
Pipe Size: 1.25 inch  
Fabrication Method: Pipe cutting and arc welding

**3.4 Moving Plank**

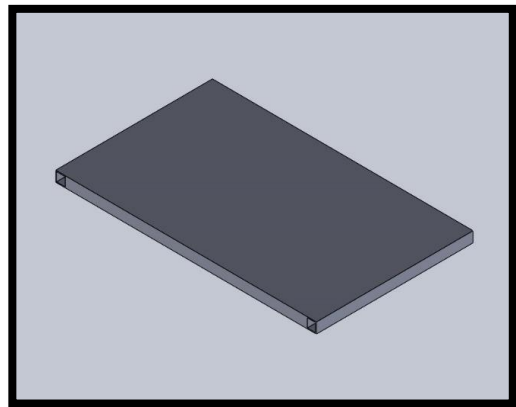

**Fig -4:** 3D design of Moving Plank

The moving plank is the main bending member of the machine. It is attached to the table frame using hinges and rotates through a quarter-circle motion to bend the condenser coil to the required angle. The plank is constructed from M.S. square pipes and covered with a G.I. sheet surface.

**Functions:**

Applies bending force on the condenser coil.  
Produces accurate and uniform bend angles.  
Ensures smooth bending operation.

**Specifications:**

Material: M.S. square pipe with G.I. sheet  
Dimensions: Length = 15 inches, Width = 25 inches  
Motion: Rotational (pivoted movement)

**3.5 Roller**

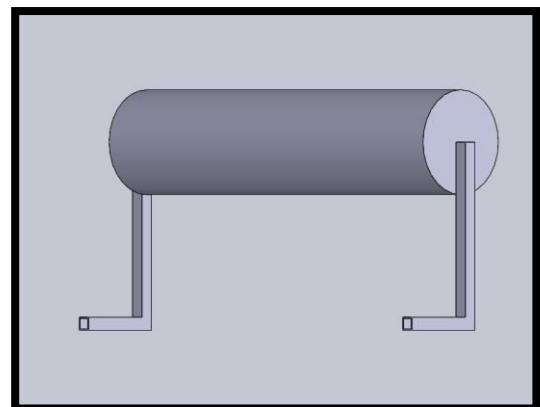

**Fig -6:** 3D design of Roller

The roller is a cylindrical component responsible for providing the required bending radius to the condenser coil. A high-strength PVC pipe is used to manufacture the roller due to its rigidity, crack resistance, and lightweight nature.

**Functions:**

Guides the condenser coil during bending.

Maintains uniform bend radius.  
Prevents deformation of the coil surface.

**Specifications:**

Material: PVC Pipe  
Diameter: 6 inches  
Length: 25 inches  
Radius: 3 inches

**3.6 Handle**

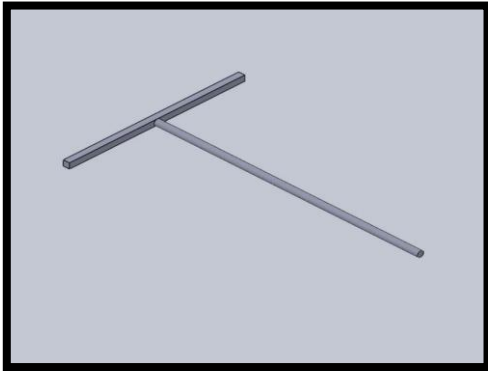

**Fig -6:** 3D design of Handle

The handle is a manually operated component connected to the height adjustment and locking mechanism. It is fabricated using a steel rod and acts as the shaft for the sprocket gear.

**Functions:**

Operates the height adjustment mechanism.  
Controls locking and unlocking of the coil.  
Transmits manual rotational force to the sprocket assembly.

**Specifications:**

Material: Steel Rod  
Diameter: 18 mm  
Manufacturing Process: Cutting and welding

**3.7 Support plate**

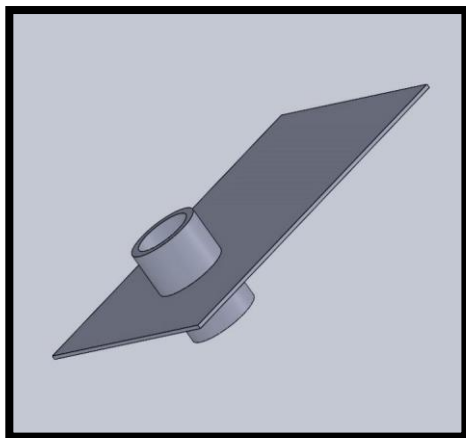

**Fig -7:** 3D design of Support plate

The support plate is an important element of the locking mechanism and provides structural support to the handle assembly. It consists of G.I. sheet with copper pipe inserts.

**Functions:**

Supports the handle shaft.  
Maintains alignment of moving components.  
Reduces friction during movement.

**Specifications:**

Material: G.I. Sheet and Copper Pipe  
Hole Diameter: 20 mm  
Copper Pipe Length: 1.5 inches

**3.8 Locking Mechanism**

The locking mechanism is used to clamp the condenser coil securely before the bending process begins. It operates by raising the upper table body upward, eliminating clearance between the roller and the coil.

**Functions:**

Locks the condenser coil in position.  
Prevents movement during bending.  
Improves bending accuracy and safety.

**Main Components:**

Handle  
Sprocket Gear  
Support Plates

**4. ADVANTAGES**

1. No electricity required
2. Cost-effective
3. Portable and durable
4. Suitable for rural applications

**5. CONCLUSIONS**

The research work titled “**Design and Development of Condenser Coil Bending Machine**” was successfully completed with the aim of developing an economical, efficient, and user-friendly solution for condenser coil bending operations used in refrigeration and air-conditioning industries. The project mainly focused on addressing the problems faced by small-scale industries, where condenser coils are generally bent manually, resulting in poor dimensional accuracy, higher labor dependency, increased production time, and risk of coil damage.

The developed machine successfully demonstrated the practical implementation of simple mechanical engineering concepts to achieve accurate and uniform condenser coil bending. The machine consists of major components such as the upper table body, lower table body, moving plank, roller, locking mechanism, handle, support plates, and sprocket-based table height adjustment mechanism. Each component was carefully designed and fabricated using suitable materials to ensure strength, durability, ease of operation, and low manufacturing cost.

The PVC roller provided a smooth and uniform bending radius, while the moving plank enabled controlled bending of the condenser coil at the desired angle. The locking mechanism ensured proper holding of the workpiece during operation, which improved bending precision and reduced the chances of coil deformation. The use of Mild Steel pipes and G.I. sheets provided sufficient rigidity and structural stability to the machine during bending operations.

Testing of the machine showed several improvements over the traditional manual bending method. The machine reduced manpower requirements, improved safety for workers, enhanced bend accuracy, and reduced production time. It was also observed that smaller condenser coils could be bent simultaneously, thereby increasing productivity. Since the machine does not require electricity for operation, it can be effectively used in small workshops and rural industrial applications where low-cost and portable solutions are preferred.

The project also provided valuable practical knowledge in the fields of machine design, material selection, fabrication, welding, assembly, and testing. The use of SOLIDWORKS software for 3D modelling helped in visualizing the machine components and minimizing design errors before fabrication. Overall, the project proved to be a successful attempt at developing a low-cost condenser coil bending machine that can serve as a practical and economical solution for small-scale industries.

### ACKNOWLEDGEMENT

We would like to express our sincere gratitude and heartfelt appreciation to everyone who directly and indirectly contributed to the successful completion of our research paper and project titled **“Design and Development of Condenser Coil Bending Machine.”**

First and foremost, we express our deepest sense of gratitude to our respected project guide,

**Mr. Sandeep S. Patil**, Lecturer, Mechanical Engineering Department, for his continuous guidance, encouragement, technical support, and valuable suggestions throughout the entire duration of this project. His knowledge, motivation, and practical approach helped us overcome various difficulties during the design, fabrication, and testing phases of the machine. Without his constant supervision and support, this project would not have been possible.

We are highly thankful to the Head of the Mechanical Engineering Department, **Mr. Jayesh D. Ramani**, for his encouragement, valuable guidance, and continuous support during the development of this project and preparation of the research paper. His motivation inspired us to complete the work successfully and efficiently.

We would also like to express our sincere thanks to our respected Principal, **Dr. Y. S. Choupare**, for providing the necessary facilities, infrastructure, workshop environment, and academic support required for carrying out this project work successfully. His support created a positive learning atmosphere that encouraged innovation and practical implementation of engineering concepts.

We are especially grateful to the management and Director of VERTI STAND for granting us permission and patent usage rights for incorporating the “Table Height Adjustment Mechanism” into our project. Their cooperation and support significantly contributed to the successful implementation of the machine design and mechanism development.

We also extend our heartfelt thanks to all faculty members of the Mechanical Engineering Department for introducing us to research methodology, engineering design principles, and practical manufacturing techniques.

Special thanks are also due to the workshop staff and technicians who assisted us during fabrication processes such as welding, drilling, cutting, grinding, and assembly work. Their practical guidance and support helped us complete the machine fabrication safely and effectively.

Finally, we would like to thank all our team members, friends, classmates, and everyone who directly or indirectly contributed to the successful completion of this project through their cooperation, suggestions, encouragement, and teamwork. Their continuous support played an important role in making this project and research paper successful.

### REFERENCES

- [1] **“Automatic Serpentine Tube Bending Machine”** by Chandrakant Balkrushna Jadhav, Digvijay Chudmunge, Rajvardhan Dalvi, Prafull Holkar, and Akshay Dhanawade, was published in the International Journal for Scientific Research and Development (IJSRD), Volume 5, Issue 2, pages 1121-1123.
- [2] **“Homogeneous charge compression ignition combustion: Advantages and challenges”** M.M. Hasan and M.M. Rahman, was published in the Renewable and Sustainable Energy Reviews, Volume 57, pages 282–291.
- [3] **“Analysis of Roller Mechanism in Tube and Pipe Bending Machines”** Y. Chen, L. Wang, was published in the Journal of Manufacturing Science and Engineering, Volume 142, Issue 6, pages 061005-1 – 061005-8.
- [4] **“Design and Fabrication of Pipe Bending Machine”** S. B. Patil, R. R. Kulkarni, was published in the International Journal of Mechanical Engineering and Technology (IJMET), Volume 9, Issue 5, pages 112–118
- [5] **“Development of a Low-Cost Tube Bending Machine for Small Scale Industries”** A. Kumar, P. Singh, was published in the International Research Journal of Engineering and Technology (IRJET), Volume 7, Issue 8, pages 1450–1456
- [6] **“Design and Structural Analysis of Mechanical Bending Machine Using SOLIDWORKS”** by M. R. Shaikh, A. Deshmukh, was published in the International Journal of Engineering Research & Technology (IJERT), Volume 11, Issue 4, pages 540–547.
- [7] **“Design of Adjustable Height Worktable Mechanism Using Mechanical Locking System”** by P. R. Mehta, D. Shah, was published in the International Journal of Engineering Research and Applications (IJERA), Volume 9, Issue 7, pages 44–50.
- [8] **“Comparative Study of Mild Steel and Aluminium for Machine Frame Applications”** by R. Jain, V. Patel, was published in International Journal of Engineering Research & Technology (IJERT), Volume 10, Issue 9, pages 411–417.
- [9] **“Material Selection in Mechanical Design Using Ashby’s Approach”** by M. F. Ashby, was published in the Book (Materials Selection in Mechanical Design), 5<sup>th</sup> edition, Year 2017, Page No 35–68