

# Design and Comparative Study of Plate Fin Heat Sink for Fan-less Cooling in CPU

Bhushan G. Pawar<sup>1</sup>  
<sup>1</sup>ME Student,  
Mechanical Engineering Department,  
Oriental College of Technology,  
RGPV, Bhopal, India

Kunal S. Marathe<sup>3</sup>  
Associate Professor,  
Mechanical Engineering Department,  
L. G. M. Institute of Engineering Education & Research,  
Nasik, India,

Dharmendra Yadav<sup>2</sup>  
Associate Professor,  
Mechanical Engineering Department,  
Oriental College of Technology,  
RGPV, Bhopal, India,

**Abstract** –Modern portable electronic devices are becoming more compact in space, The exponential increase in thermal load in air cooling devices require the thermal management system (i.e. heat sink) to be optimized to attain the highest performance in the given space. In this work, experimentation is performed for high heat flux condition. The heat sink mounted on the hot component for cooling the component under forced convection. The two different orientation of fan i.e. “fan-on-top” and “fan-on-side” are tested for different air mass flow rate and cooling rate is validated with numerical results for the same amount of heat flux. The numerical simulation is performed using computational fluid dynamics (CFD). The primary goal of this work is to do the thermal analysis and comparison of fan orientation on cooling efficiency and to find the optimum parameters for a natural air-cooled heat sink at which the system will continue its operation in natural convection mode (i.e. Fan-failed condition). The CFD simulations are performed for optimization of heat sink parameters with objective function of maximization of heat transfer coefficient.

**Keywords** - Heat sink, experimentation, computational fluid dynamics, heat transfer coefficient

## I. INTRODUCTION

It is observed that components of modern portable electronic devices with increasing heat loads with decrease in the space available for heat dissipation. The increasing heat load of the device needs to be removed otherwise overheating situation could affect both the stability and performance of the working device. The exponential increase in thermal load in air cooling devices requires the thermal management system (i.e. heat sink) to be optimized to attain the highest performance in the given space. Over the past few decades there is increasing interest in the development of the heat sink process for heat dissipation and many design methodologies regarding optimization of heat sink have been proposed. Kyoungwoo Park [1] used Kriging method and CFD tool to an optimization of heat sink. Matthew B. de. Stadler [2] figure out difficulty in using fixed temperature boundary condition for hot surfaces and role of cellular materials while optimization of heat sinks. Some unknown Characterize the performance of several fan heat sink designs and find out a theoretical methodology that would accurately predict both optimization point for a given space as well as the performance of the solution. Dong-Kwon Kim [3] check the thermal performance of plate fin heat sink with variable fin thickness and observes thermal resistance was reduced as much as 15 % compared to uniform fin thickness heat sink. Adriano A.Koga.et.al [4]

proposed development of heat sink device by topology optimization. Sidy Ndao et.al [5] concluded from multi objective thermal design optimization and comparative analysis of electronic cooling technologies that Single objective optimization of either the thermal resistance or pumping power may not necessarily yield optimum performance. The multiple-objective optimization approach is preferable as it provides a solution with different trade-offs among which designers can choose from to meet their cooling needs. The choice of a coolant has a significant effect on the selection of a cooling technology for a particular cooling application. Chayi-Tsong Chen, and Hung-I Chen observed that direction based genetic algorithm is very effective in locating the pareto front of the multi objective design The optimally designed heat sink by the proposed approach is shown to be superior in heat dissipation than those reported in literature. Lin Lin et.al [6] observes Increasing the pumping power, volumetric flow rate or Pressure drop can enhance the cooling performance of double layer MCHS, however this enhancement effect becomes weaker at higher pumping powers, volumetric flow rates, and pressure drops. Paulo Canhoto and A Heitor Reis [7] address the optimization of a heat sink formed by parallel circular ducts or non circular ducts in a finite volume and found that The optimum dimensionless thermal length and optimum hydraulic diameter were found for achieving maximum heat transfer density at fixed pumping power. Dong-Kwon Kim et.al [8] shown that optimized pin-fin heat sinks possess lower thermal resistances than optimized plate-fin heat sinks when dimensionless pumping power is small and the dimensionless length of heat sinks is large. On the contrary, the optimized plate-fin heat sinks have smaller thermal resistances when dimensionless pumping power is large and the dimensionless length of heat sinks is small. R.Mohan and Dr. P. Govindrajan [9] did thermal analysis of CPU with pin fin and slot parallel plate heat sinks with copper and carbon carbon composites. Ravi Kandasamy *et.al* [10] investigated application of novel PCM package for thermal management of portable electronic devices experimentally for studying effect of various parameters under cyclic steady condition. Maciej Jaworski [11] address thermal performance of heat spreader for electronic cooling with incorporated phase change materials.

In this work experimentation is performed to find out better orientation of fan and no fan (Fan failed) condition the results of the experiment are validated by CFD .The objective of this work is to find out optimum parameters for naturally air cooled heat sink at which the system will continue its operation smoothly in natural convection mode. And comparisons of optimized heat sink with commercially available heat sink on the basis of various thermal and geometrical properties.

II. EXPERIMENTAL SETUP

Fig.1 represents the experimental testing set up which consist of a 80mm×60mm plate heater attached below the heat sink using a thin layer of thermal conducting paste Omegatherm 201.This attachment reduces the contact resistance and air gap between the surfaces, thus enhancing thermal conductivity during heat transfer. The heater can provide input power up to 80W to simulate the heat source. An adjustable DC power supply is connected to the heater. The maximum voltage across heater is 24V DC.

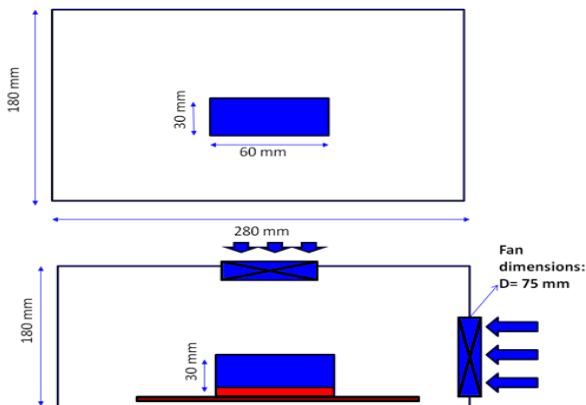

Fig. 1. Front view of experimental set up

The heat sink with attached heater is enclosed in a cabinet (280X150X180) and made of 5 mm thick acrylic, which has a melting temperature of 170°C and a thermal conductivity of 0.2W/mK. Two axial fans of SIBAS (V=220 V, I=0.09 A, P=17 W, N=2500 rpm) are screwed to the cabinet casing out of which first one is mounted the top side of the heat sink and second one on right side in order to enhance the heat transfer. The heater is insulated from the casing using a backlilte plate of 10 mm thickness followed by mica sheet of 1 mm thickness and ceramic wool of 10 mm thickness. This prevents heat loss from the heater to the acrylic plastic casing. To study the natural convection phenomenon inside the test set up, upper surface has not given any insulation. Rubber ‘O’ rings are placed on the both sides of the heat sinks before the device is sealed with M3 screws and epoxy. The metal screws hold the heat-transferring blocks tightly to the aluminum heat sink in order to avoid the contact resistance due to air gap. The setup is placed inside a black box to reduce environmental effects due to lights, flows from air-conditioning fans and other disturbance. Four omega-type thermocouples are used for testing. First thermocouple is attached around the external surface of the heat sink. Second thermocouple is attached in between the heater and the heat sink. Third and fourth thermocouples are placed inside the cabinet near to the fans. The second end of each thermocouple is dipped in an ice bath for thermocouple calibration.

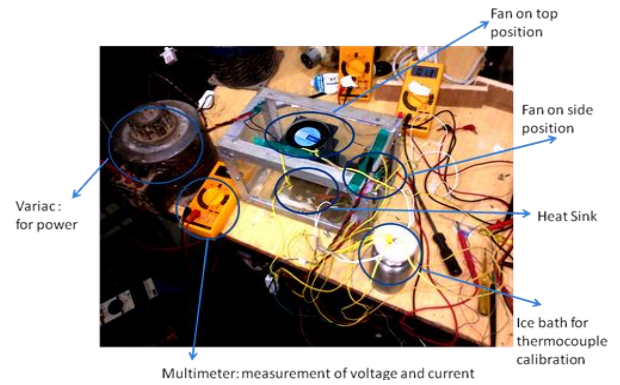

Fig.2.experimental set up

The opposite end of each thermocouple is attached to multimeter in order to record the temperature of each thermocouple.

III. PROCEDURE

In this experiment the readings are taken for three main conditions i.e fan on side (FOS), fan on top (FOT) and no fan (fan failed) condition. Different heat inputs are given to the heater through power source and variac is used to regulate power supply and for giving different heat inputs. The temperature across the components is recorded after steady state is reached. The experimentation is performed for the above mentioned conditions with varying mass flow rate of air and at different heat inputs.

IV. RESULTS & DISCUSSION

In this experiment the primary goal was to study the heating effect in the system at different input powers and with different fan orientation (i.e. FOT and FOS). The first set of readings was taken for finding heat sink temperature at 25 W and 65 W resp. for fan on side condition, with varying mass flow rate of air. The same set of readings was taken for the fan on top condition.

Table I  
Readings of Mass Flow Rate And Heat Sink Temperature At 25w

Mass Flow Rate(m <sup>3</sup> /s)	Fan On Side Heat Sink Temperature	Fan On Top Heat Sink Temperature
0.0145	53	88.02
0.0217	41.3	81.96
0.0434	31.7	69.2

Table II  
Readings of Mass Flow Rate and Heat Sink Temperature At 65w

Mass Flow Rate(m <sup>3</sup> /s)	Fan On Side Heat Sink Temperature	Fan On Top Heat Sink Temperature
0.0145	68.7	90.4
0.0217	59.1	83.2
0.0434	49.5	79

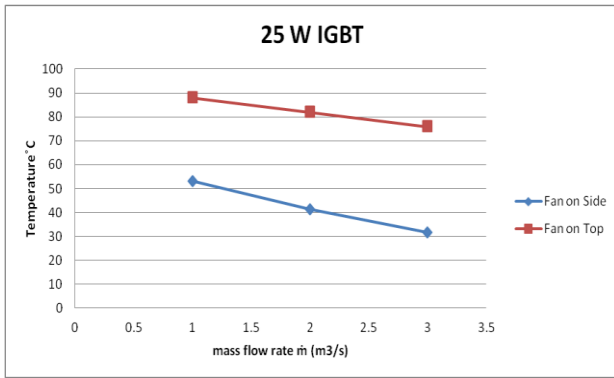

Fig. 3. Temp. Vs mass flow rate at 25 W

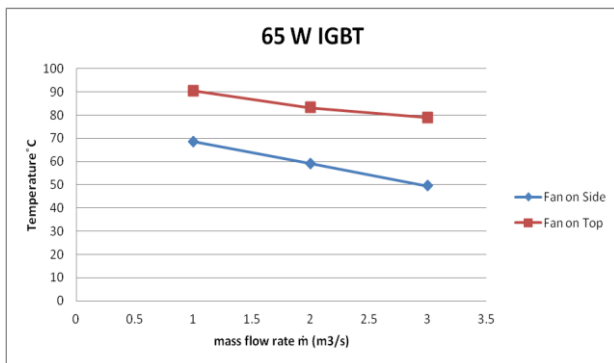

Fig. 4. Temp. Vs mass flow rate at 65 W

From the above graphs it is observed that in “fan on side” condition max temp of heat sink is 31.7 °C for 25 W heat source and 49.5 °C for 65W heat source for given air flow rate of 0.0434. For “fan on top condition” max temp of heat sink is 69 °C for 25 W heat source and 79 °C for 65W heat source for given air flow rate of 0.0434. From the above results it can be concluded that “Fan on side” condition is best orientation condition for minimizing the temp of heat sink. Hence “Fan on side” condition is the best orientation condition for given experimental setup.

*Fan failed condition*

In most of the electronic components it is observed that when the temperature in the device exceeds the IGBT permissible temperature there may be unstable performance of the system due to improper functioning of fan (i.e fan failed condition). Further study is carried out to observe the behavior of the heat sink under no fan condition (i.e fan failed condition). The IGBT permissible temperatures and actual temperatures of component are recorded experimentally.

Table III

Igbt Temperature and Actual Temperature of Component At 25w and 65w

Power Input (W)	IGBT Permissible Temp. (°C)	Actual Temp. of the component (°C)
25	85	90
65	105	112

From the above table it is observed that actual temperature at the heat sink exceeds the permissible temperature of IGBT component. Same results are validated numerically using computational fluid dynamics study.

*CFD Validation of Experimental Results*

For this study set of equations are solved. These equations are

- Coordinates : (x, y, z)
- Time : t
- Pressure : p
- Heat Flux : q
- Velocity Components : (u, v, w)
- Density : ρ
- Stress : ζ
- Reynolds No. : Re.
- Total Energy : ET
- Prandtl No. : Pr.

Continuity Equation:

$$\frac{\partial \rho}{\partial t} + \frac{\partial(\rho u)}{\partial x} + \frac{\partial(\rho v)}{\partial y} + \frac{\partial(\rho w)}{\partial z} = 0$$

X Momentum Equation

$$\frac{\partial(\rho u)}{\partial t} + \frac{\partial(\rho u^2)}{\partial x} + \frac{\partial(\rho uv)}{\partial y} + \frac{\partial(\rho uw)}{\partial z} = -\frac{\partial p}{\partial x} + \frac{1}{Re} \left[ \frac{\partial \zeta_{xx}}{\partial x} + \frac{\partial \zeta_{xy}}{\partial y} + \frac{\partial \zeta_{xz}}{\partial z} \right]$$

Y Momentum Equation

$$\frac{\partial(\rho v)}{\partial t} + \frac{\partial(\rho uv)}{\partial x} + \frac{\partial(\rho v^2)}{\partial y} + \frac{\partial(\rho vw)}{\partial z} = -\frac{\partial p}{\partial y} + \frac{1}{Re} \left[ \frac{\partial \zeta_{xy}}{\partial x} + \frac{\partial \zeta_{yy}}{\partial y} + \frac{\partial \zeta_{yz}}{\partial z} \right]$$

Z Momentum Equation

$$\frac{\partial(\rho w)}{\partial t} + \frac{\partial(\rho uw)}{\partial x} + \frac{\partial(\rho vw)}{\partial y} + \frac{\partial(\rho w^2)}{\partial z} = -\frac{\partial p}{\partial z} + \frac{1}{Re} \left[ \frac{\partial \zeta_{xz}}{\partial x} + \frac{\partial \zeta_{yz}}{\partial y} + \frac{\partial \zeta_{zz}}{\partial z} \right]$$

Energy Equation

$$\frac{\partial(E_T)}{\partial t} + \frac{\partial(uE_T)}{\partial x} + \frac{\partial(vE_T)}{\partial y} + \frac{\partial(wE_T)}{\partial z} = -\frac{\partial(Up)}{\partial x} - \frac{\partial(vp)}{\partial y} - \frac{\partial(wp)}{\partial z} - \frac{1}{RePr} \left[ \frac{\partial q_x}{\partial x} + \frac{\partial q_y}{\partial y} + \frac{\partial q_z}{\partial z} \right] + \frac{1}{Re} \left[ \frac{\partial}{\partial x} (u\zeta_{xx} + v\zeta_{xy} + w\zeta_{xz}) + \frac{\partial}{\partial y} (u\zeta_{xy} + v\zeta_{yy} + w\zeta_{yz}) + \frac{\partial}{\partial z} (u\zeta_{xz} + v\zeta_{yz} + w\zeta_{zz}) \right]$$

Set of equations are solved using pressure based model. Staggered grid arrangement is taken for study. For pressure velocity coupling SIMPLE algorithm is considered. Second order upwind scheme is considered for discretising the momentum equation. For turbulence modeling K-E model is considered. For meshing the geometry, fine sgrid is used to near Fan, velocity boundary layer is need to be captured for getting accurate profile. Fine grid is also used near heat sink fins in order to capture thermal boundary layer. In rest of the domain where physics change is not prominent, coarse grid is used to save computational time.



For "Fan on side condition" and at 25 W (IGBT)

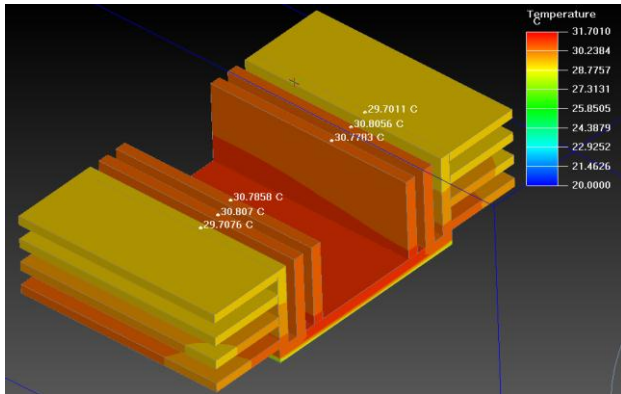

Fig. 5. Thermal image of Heat sink for Fan on side condition at 25 W

From the above contours it is seen that maximum temperature reached is 29.7°C. Same Case when examined experimentally shows maximum temperature of 31.7 °C.

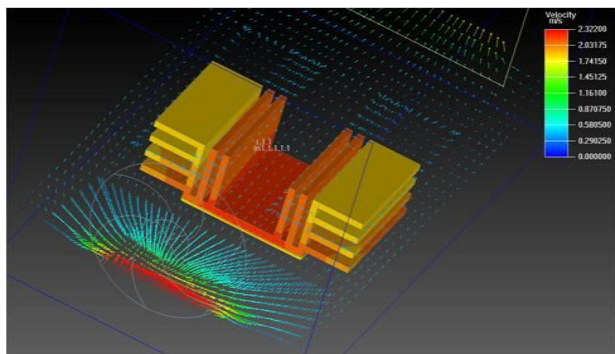

Fig. 6. Thermal image of Heat sink for Fan on side condition at 25 W

For Fan on Top condition and at 25 W (IGBT)

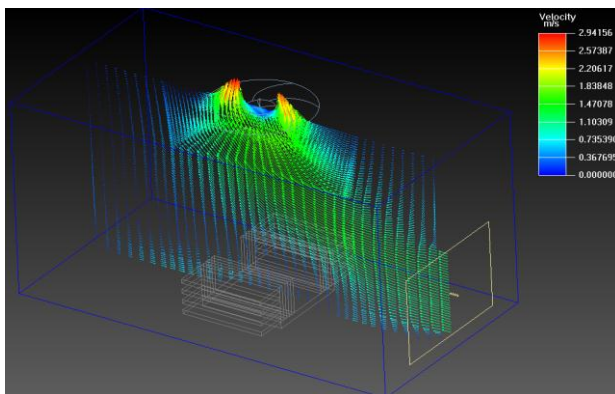

Fig. 7. Velocity vector image of Heat sink for Fan on Top condition at 25 W  
From the above contours it is seen that maximum temperature reached is 71.7 °C. Same Case when examined experimentally shows maximum temperature of 69.2 °C.

For Fan on Side condition and at 65 W (IGBT)

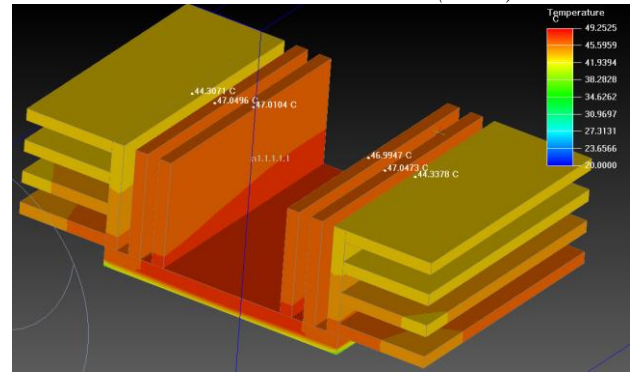

Fig. 8. Thermal image of Heat sink for Fan on side condition at 65 W

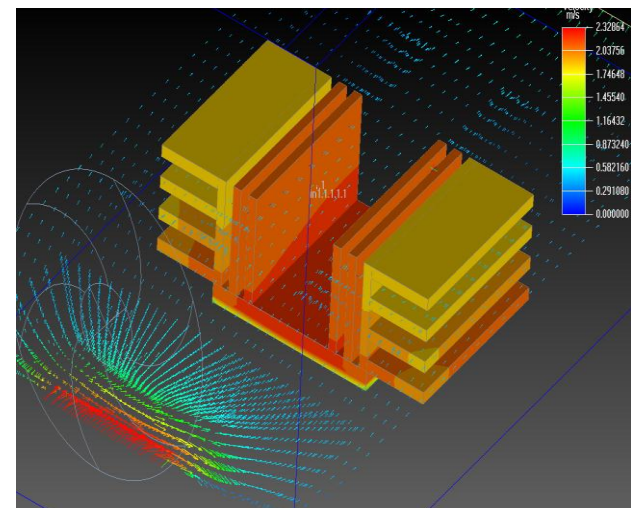

Fig. 9. Velocity vector image of Heat sink for Fan on side condition at 65 W

From the above contours it is seen that maximum temperature reached is 47 °C. Same Case when examined experimentally shows maximum temperature of 49.5 °C.

For Fan on Top condition and at 65 W (IGBT)

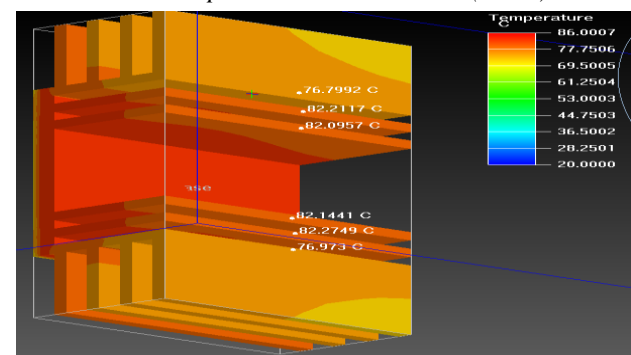

Fig. 10. Thermal image of Heat sink for Fan on Top condition at 65 W

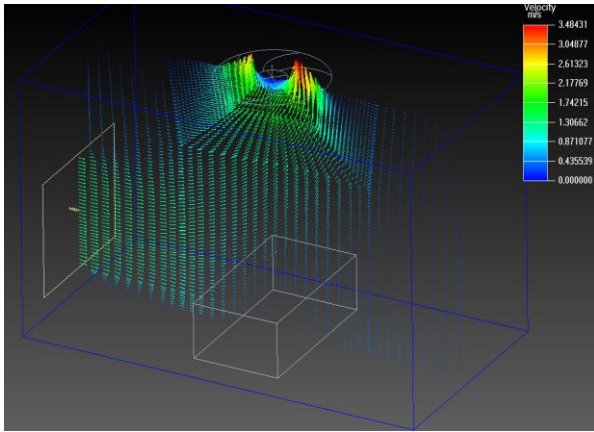

Fig. 11. Velocity vector image of Heat sink for Fan on side condition at 65W

From the above contours it is seen that maximum temperature reached is 97.37°C. Same Case when examined experimentally shows maximum temperature of 90 °C.

For 65 W

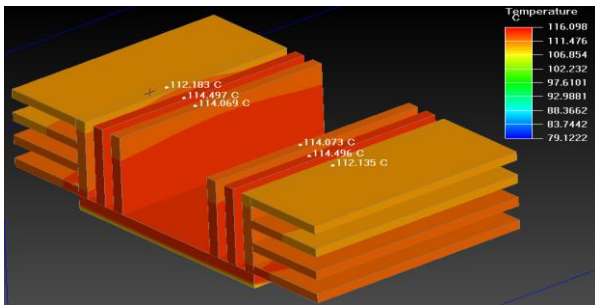

Fig. 12. Thermal image of Heat sink for Fan Failed condition at 65 W

From the above contours it is seen that maximum temperature reached is 115°C. Same Case when examined experimentally shows maximum temperature of 112°C. The results of all the above all configurations with respective error in experimental results and numerical results are tabulated below.

For 25 W

TABLE IV  
TEMPERATURE OF HEAT SINK IN EXPERIMENT AND IN CFD WITH ORIENTATION OF FAN AT 25W

Fan Orientation	Temp. (Experiment) (°C)	Temp. (CFD) (°C)	Error
FOS	31.7	29.7	6.309
FOT	69.2	71.7	-3.673
NO FAN	90	97.37	-8.189

For 65 W

TABLE V  
TEMPERATURE OF HEAT SINK IN EXPERIMENT AND IN CFD WITH ORIENTATION OF FAN AT 65W

Fan Orientation	Temp. (Experiment) (°C)	Temp. (CFD) (°C)	Error
FOS	49.5	47	5.051
FOT	79	82	-3.797
NO FAN	112	115	-2.232

The tabulated CFD results show much similarity with the experimental results with minor error. It is observed that when fan is not working i.e. No Fan Condition, there is exponential increase in the temperature of the heat sink. In order to withstand the fan failed condition above results drives our attention to a point where there is needs to optimize the heat sink. So further study is carried out to optimize heat sink for fan failed condition. (For Natural convection)

Optimization of Heat Sink for Fan Failed Condition

Optimization is performed with the help of CFD study. Optimization is carried out with varying fin thickness, fin spacing and no. of fins. On trial and error basis various configurations of heat sink design are obtained. Out of which two cases are presented below the second case gives best result for the optimized heat sink.

TABLE VI  
OPTIMIZATION OF RESULTS OF HEAT SINK IN CFD

Case	No. of vertical fins	Fin thickness (mm)	No. of horizontal fins	Fin Thickness (mm)
Base Case	3	3	4	3
Case-I	4	2.5	5	2.5
Case-II	4	2.5	6	2

Case-I shows the CFD simulation at given input powers i.e at 25 W and 65 W respectively. The temperature at the heat sink observed to exceed than the IGBT permissible temperature that's why case-I fails for the optimization of heat sink.

At 25 W

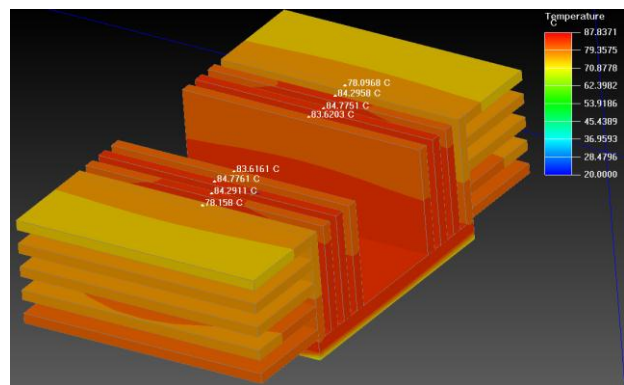

Fig. 13. Thermal image of Heat sink (Case-I) for Fan Failed condition at 25 W

At 65 W

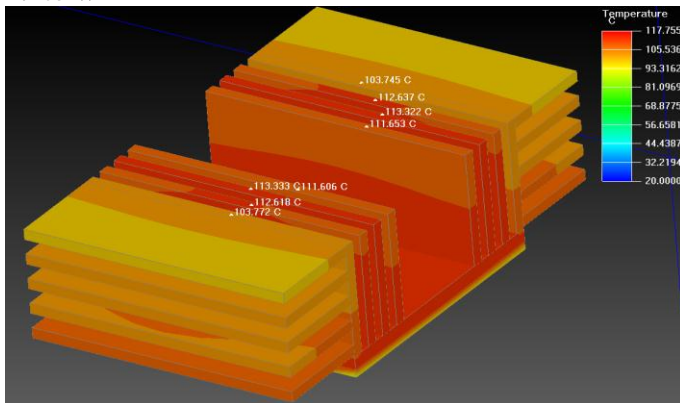

Fig. 14. Thermal image of Heat sink (Case-I) for Fan Failed condition at 65 W

Case-II shows the CFD simulation at given input powers i.e at 25 W and 65 W respectively. The temperature at the heat sink observed to be much less than the IGBT permissible temperature that's why case-II gives the best optimized results for the given heat sink.

At 25 W

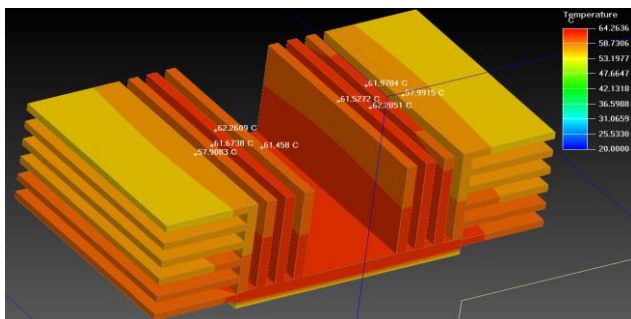

Fig. 15. Thermal image of Heat sink (Case-II) for Fan Failed condition at 25 W

At 65 W

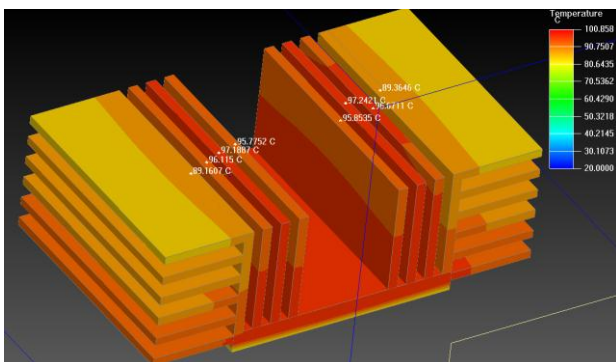

Fig. 17. Thermal image of Heat sink (Case-II) for Fan Failed condition at 65 W

The optimized results in terms of temperature for all the cases and for No fan (Fan failed) condition are given below

Table VI

Optimization Results of Heat Sink In Cfd In Terms Of Temperature			
Input Power(W)	Base Case (HS Temp)	Case-I (HS Temp)	Case-II (HS Temp)
25	90	84	64
65	112	111	95

Same results are represented graphically. In this red line shows permissible temperature limit for given IGBT.

At 25 W

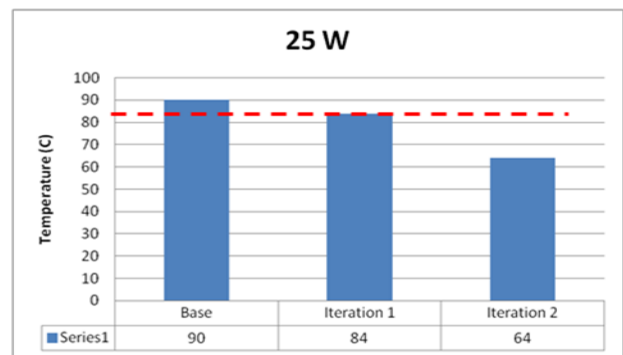

Fig. 18. Graph of Comparison of Case-I and Case-II at 25 W

At 65 W

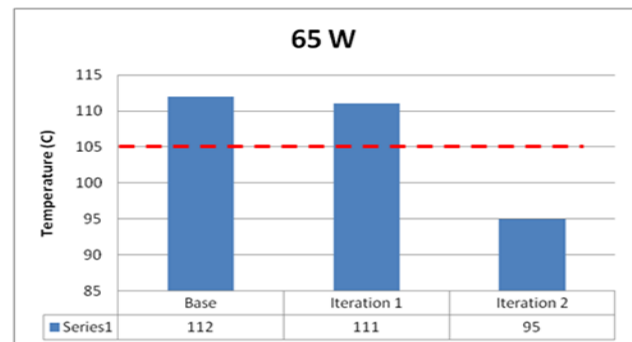

Fig. 19. Graph of Comparison of Case-I and Case-II at 65 W

From the above results it is clear that case II is the best optimized condition for given heat sink setup.

### V. CONCLUSION

In this experiment the primary goal is to study the performance of heat sink with different orientation of the fan. The experimental and numerical study is performed. It is observed that fan on side gives the better performance than fan on top. The main objective of this study is to find better configuration of a heat sink which can work smoothly even after the temperature inside the component exceeds the IGBT permissible temperature. Best optimized configuration of given heat sink has been found. This is achieved with the help of experimental & numerical study.



## ACKNOWLEDGMENT

I wish to express my sincere gratitude to my guide Prof. Dharmendra Yadav for guidance and help which had gone a long way in the process of completion of this paper .

## REFERENCES

- [1] Kyoungwoo Park., Park-Kyoun oh., Hyo-Jae Lim., The application of the CFD and Kringing method to an optimization of heat sink, International Journal of Heat and Mass Transfer 49 (2006) 3439-3447 ,Elsevier 2006.
- [2] Matthew B. de Stadler., Optimization of the geometry of a heat sink, university of Virginia, Charlottesville, VA22904
- [3] Kim D., Jung J., Kim S.,Thermal optimization of plate-fin heat sinks with variable fin thickness, International Journal of Hear and Mass Transfer 53(2010) 5988-5995,Elseveir,2010.
- [4] Koga A., C Edson., Nova H., Lima C., Silva E., Development of heat sink by using topology optimization , International Journal of Hear and Mass Transfer 64 (2013) 759-722
- [5] Ndao S., Peles Y., Jenson M.K., Multi-objective thermal design optimization and comparative analysis of electronics cooling technologies, International Journal of Hear and Mass Transfer 52 (2009) 4317-4326, Elseveir, 2009.
- [6] Tsong C.,and Chen H.,Multi-objective optimization design of plate fin heat sink using a direction based genetic algorithm,Journal of the Taiwan Institute of chemical Engineers 44(2013) 257-265 Elseveir 2013
- [7] Lin Lin, Yang Yang Chen ,Optimization of geometry and flow rate distributin for double layer microchannel heat sink,International journal of Thermal Sciences 78(2014) 158-168 ELSEVIER
- [8] anhoto P., Reis A., Optimization of forced convection heat sinks with pumping power requirements , International Journal of Hear and Mass Transfer 54 (2011) 1441-1447,Elseveir 2010. "PDCA12-70 data sheet," Opto Speed SA, Mezzovico, Switzerland.
- [9] Kim D., Jung J., Kim S.,Thermal optimization of plate-fin heat sinks with variable fin thickness, International Journal of Hear and Mass Transfer 53(2010) 5988-5995,Elseveir,2010.
- [10] R.Mohan and Dr.P.Govindrajan., Thermal analysis of CPU with Composite pin fin heat sinks, International journal of engineering science and technology vol2(9),2010,4051-4062
- [11] S.C.Fok, W. Shen, F.L.Tan., Cooling of portable hand held electronic devices using phase change materials in finned heat sinks, International journal of thermal sciences 49(2010) 109-117,Elsevier, 2009.

## BIOGRAPHY

Author 1: Bhushan G. Pawar:

Completed his Bachelor of Engineering in Mechanical, Master of Business Administration in Marketing and Human Resource from Savitribai Phule Pune University, Advanced Diploma in Industrial Safety from Maharashtra State Board of Technical Education and currently pursuing Master of Technology in Thermal Engineering from Rajiv Gandhi Proudयोगिकी Vishwavidyalaya University Bhopal, Madhya Pradesh.

Author 2: Dharmendra Yadav

Completed his Bachelor of Technology in Mechanical and Master of Technology in Thermal Engineering from Rajiv Gandhi Proudयोगिकी Vishwavidyalaya University, Bhopal, Madhya Pradesh, Currently working as an Assistant Professor in Department of Mechanical Engineering at Oriental College of Technology, Bhopal.

Author 3: Kunal S. Marathe

Completed his Diploma in Mechanical Engineering from Maharashtra State Board of Technical Education, Bachelor of Engineering in Mechanical & Master of Engineering in Mechanical- Design from Savitribai Phule Pune University, Currently working as an Assistant Professor at Loknete Gopinathji Munde Institute of Engineering Education & Research, Nashik.