

Condition Monitoring of a Dynamic System using Artificial Intelligence

Prof.Prafulla Patil
Department of Instrumentation
Mumbai,India

Kamlesh Lohar
Department of Instrumentation
Mumbai,India

Ruth George
Department of Instrumentation
Mumbai,India

Divyang Trivedi
Department of Instrumentation
Mumbai,India

Akanksha Kulkarni
Department of Instrumentation
Mumbai,India

Abstract—several machines consist of multiple rotating mechanisms, some of which are very complex and critical for operation. These rotating components give out vibrations during operation. Different components of the machine have different natural frequency of vibration. Here we have considered three source of vibrations – bearing failure, unbalanced mass and misalignment of shaft. If the amplitudes of these vibrations surpass the limiting value, it indicates the abnormal behaviour of the machinery and might cause severe damage. It is essential to identify the source of vibration that lead to failure of machine. An effective diagnostic system is needed to predict the condition and reliable lead time of the machine. In this study, Tri-Axial accelerometer is used to sense vibrations of the machine. If the vibration deviates from the standard value that is the natural frequency of vibration, the transducer measures that and it sends the data to the controller which selects the dominating amplitude and frequency and transmits these data to Artificial Intelligence (AI) code wirelessly using Ethernet. These received data is processed by Naïve Bayes Algorithm which uses probabilistic approach to predict the exact source of vibration.

Keywords: Predictive Maintenance, Condition Monitoring, Abnormal Vibrations, Tri-Axial accelerometer, Artificial Intelligence, Multinomial Naïve Bayes algorithm.

I. INTRODUCTION

The principle of this study is that every dynamic mechanism vibrates periodically when in isolation, however when there happen to be multiple dynamic motions in the same setup simultaneously, the periodicity of the vibration pattern is disrupted and the resultant vibrations are obtained. If the vibration exceeds the threshold, they may become detrimental and would affect the performance of the machine, also it would not be easy to figure out exactly which of the components is causing such anomalous vibrations.

Predictive Maintenance

Failures occurring in the machines may be expensive and also affects the overall working of the equipment. Repairing or replacing such components frequently on its failure is tedious, time consuming and a lot of capital is spent on the testing and maintenance of it. Safety being a major concern, routine checking of the setup is too required. Predictive Maintenance (PdM) is a process for monitoring equipment during operation in order to identify any deterioration,

enabling maintenance to be planned thus reducing the operational cost [1]. Vibration based condition monitoring can be used to detect and diagnose machine faults and form the basis of a Predictive Maintenance strategy [2].

Industrial Vibration Analysis

Industrial vibration analysis is a measurement tool used to identify, predict, and prevent failures of rotating machinery in heavy industries like paper cutting, iron and steel, textile industry and many other production industries [7]. Applying the analysis of vibration onto the equipment can ameliorate reliability of the machines, improve the efficiency and minimize the failure rate [3]. Condition monitoring is used in heavy industries where blowers, atomizer, motor bearings, gearboxes, rotors are used.

Source of Vibration

Defect in the bearings is one of the sources of vibration in the machinery. Bearing defects may be due to excessive load, loose or tight fits [16]. Another source of vibration in the machinery is unbalanced mass condition. In this condition, the mass around the axis of rotation is unequally distributed. This results in unbalance forces acting on the system, leading to excessive vibrations. Other source of vibration considered in this study is misalignment of shaft which is caused due to looseness of nut and bolt leading to abnormal vibrations. Under operation, such defects could lead to severe damage.

II. ABBREVIATIONS AND ACRONYMS

MEMS	Micro-Electro-Mechanical Systems
PdM	Predictive maintenance
VBR	Vibration
SFD	Shear force theory
BMD	Bending moment theory
AI	Artificial intelligence
ML	Machine Learning

The study is divided into three stages that are -

- Fabrication of the testing setup
- Sensor interfacing
- AI coding and its training.

III. TESTING SETUP DESIGN -

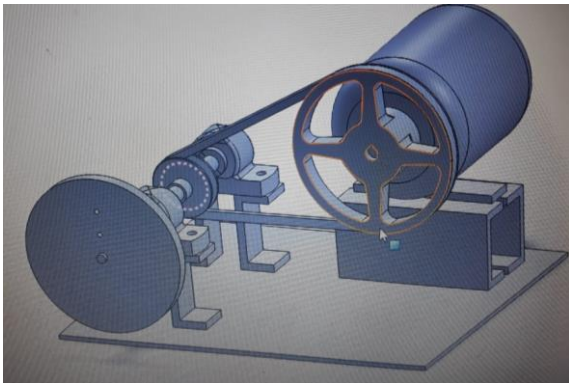

Fig1. Source of vibrations

Equations:

The transmission ratio is the ratio of input speed to the output speed. In order step up the speed on the shaft side inverse transmission ratio is used. The input speed (N_1) is 1440 rpm.

$$i = \frac{D_1}{D_2} = \frac{N_2}{N_1}$$

$$= \frac{203.3}{76.2}$$

$$= 2.667$$

For the speed of shaft

$$2.667 = \frac{N_2}{1440}$$

$$N_2 = 3842 \text{ rpm}$$

The pulleys are selected according to the standard A-section V- belt pulleys on the basis of the transmission ratio and speeds [6]. Motor of 0.5 hp is used in the setup.

Diameter of Shaft

According to the theory of SFD and BMD [8], the bending moment at point C is maximum which is 3090 N-mm and the torsional moment is given by-

$$M_t = (T_1 - T_2) \frac{R_1}{2} = (47.049 - 22.719) \times 101.65$$

$$= 2473.144 \text{ N-mm}$$

$$M_E = \sqrt{M_b^2 + M_t^2}$$

$$= \sqrt{3090.9^2 + 2473.14^2}$$

$$= 3958.55 \text{ N-mm}$$

$$d^3 = \left\{ \frac{16}{\pi \times \tau} \sqrt{M_t^2 + M_b^2} \right\}$$

$$= \frac{16}{\pi \times \tau} \times 3958.55$$

$$= 7.6508 \text{ mm}$$

Nomenclature

- N_1 - input speed
- N_2 - output speed
- D_1 - diameter of larger pulley
- D_2 - diameter of smaller pulley
- i - transmission ratio
- M_t - torsional moment
- M_b - bending moment
- d - diameter of shaft
- τ - shear stress
- hp - horsepower

The minimum value of the diameter of shaft has to be 8mm thus shaft is manufactured with a diameter of 20mm.

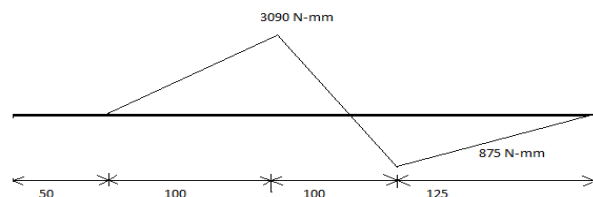

Fig2. BMD

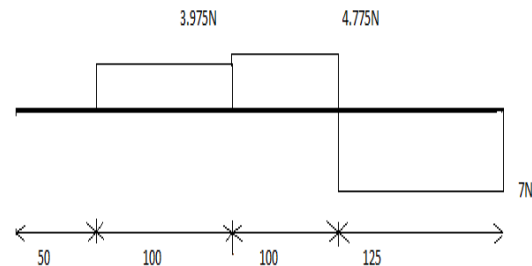

Fig3. SFD

Table 1

Electrical Components

Sr No.	Components	Description
1	Tri-Axial accelerometer	MEMS Vibration Sensor
2.	RS485 to USB Converter	Serial data trans-receiver
3.	Ethernet Shield	Wireless data transmission
4.	Motor	0.5 hp, single phase, 1440 rpm

IV. VIBRATION SENSOR -

Sensor interfacing with RS-485 to USB converter and controller is depicted in figure 4.

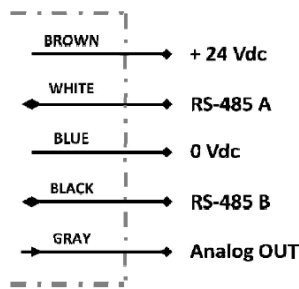

Fig4. Electrical Diagrams of the connections

Principle & Working

Sensor used in this study works on a principle of piezoelectric effect. The effect is a direct conversion of mechanical energy into electrical energy in a crystalline material composed of electric dipoles. It has a natural application in sensing vibration and acceleration. Acceleration of the case moves it relative to mass, which exerts a force on the crystal. The output is directly proportional to the acceleration or vibration level [4].

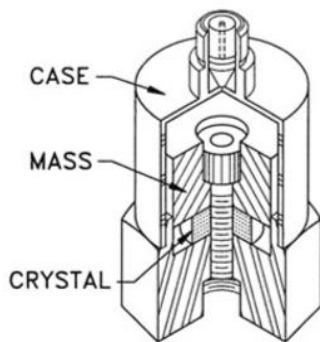

Fig5. Schematic Diagram

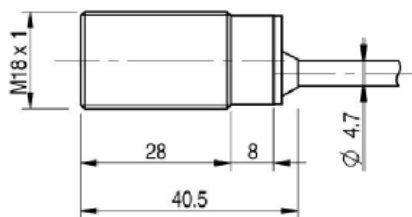

Fig6. Sensor Dimensions

Table 2

Technical Data

Supply Voltage	24 Vdc +/- 20%
Consumption	< 1 W
Operative Range	+/- 16 g (MAX)
Resolution	15,62 mg @ +/- 2 g 31,25 mg @ +/- 4 g 62,50 mg @ +/- 8 g 125 mg @ +/- 16 g

Frequency Range	400 Hz
Voltage Analogue Output	0.5 V / 0.10 V (programmable)
Current Analogue Output	4-20 mA / 0.20 mA / 0.24 mA (programmable)
Load Resistance (voltage)	1k-1M Ohm
Load Resistance (current)	100-500 Ohm
Humidity	< 80 % without condensation

Table 3

Mechanical Components

Sr No.	Components	Description
1.	Bearings	φ20 mm, seal master type,
2.	Pulley	Aluminium alloy, φ8 inches and φ3 inches
3.	MS Base Plate	Mild steel
4.	Shaft	EN8 φ20 mm and 395 mm length
5.	Channel	Mild steel C-type
6.	Rubber Pad	Hard Rubber
7.	Disc	Cast iron, φ8 inches

V. ARTIFICIAL INTELLIGENCE

Predictive maintenance is the monitoring of system's condition over its life cycle to provide a prognosis to when maintenance is required. The Predictive maintenance tools are increasingly dependent on machine learning (ML) based artificial intelligence (AI) technology [9]. Currently, there is no architecture or framework that provides a standard of practice for how data should be structured per method of Predictive Maintenance analysis dependent on ML [10]. Thus, data-driven predictive maintenance algorithms could be limited in the ability to provide accurate and current information depending on choice in ML-based analysis [11].

Naïve Bayes Algorithm

Naïve Bayes classifier works on probabilistic approach and is a common method for classification. We will be using Naïve Bayes as it is easy to implement and also gives high efficiency as compared to other AI algorithms [12]. The Naive Bayes method is a classification method based on Bayes' Theorem and the conditional independence assumption [13].

For a given training set, $T = \{(x_1, y_1), (x_2, y_2), \dots, (x_n, y_n)\}$.

Naïve Bayes first learns the joint probability distribution (x,y) of the input and output by the conditional probability distribution based on the conditional independence

assumption. The output label with the biggest posterior probability for the given input can be calculated [14].

Bayes theorem says that,

$$p(c_j/d) = p(d/c_j) * p(c_j)/p(d)$$

where,

$p(c_j/d)$ is probability of instance d being in class c_j .

$p(d/c_j)$ is probability of generating instance d given class c_j .

$p(c_j)$ is probability of occurrence of class c_j .

$p(d)$ is probability of instance d occurring.

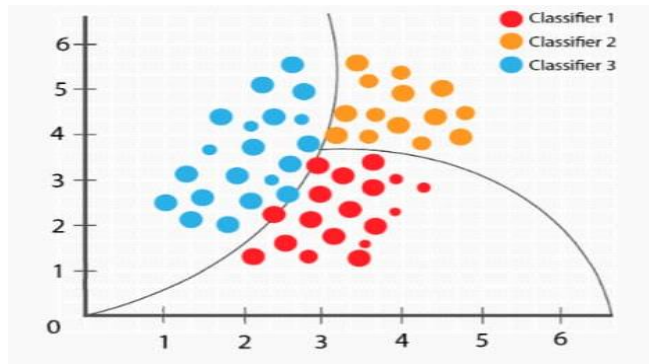

Fig7. Naïve Bayes classifier

Multinomial Naïve Bayes

As we have multiple variants i.e in case of our project different frequency and amplitude combination, we will be using multinomial Naïve Bayes [15]. It estimates the conditional probability of a particular instance given in a class as the relative frequency of term belonging to class. The variation takes into account the number of occurrences of term in training from class, including the multiple occurrences.

VI. RESULT

In this study, the sources of vibration considered are mass unbalance, misalignment of shaft and fault in bearings. The amplitude of the frequency of these vibration sources along with the ideal conditions are recorded and stored in CSV file (dataset) to analyze the defect in the rotating machine. Excessive vibrations are purposely added in the machine while it is in operating state. Then the AI code predicts the source of abnormal vibration by comparing with the ideal values stored in the CSV file. Abnormal vibration source in the testing setup while in operation, is predicted using Artificial Intelligence.

VII. FUTURE SCOPE

Accessing the machineries remotely via GNU radio in real time is the future work that can be achieved after

implementing Artificial intelligence for predicting the abnormal vibration source [5].

VIII. REFERENCES

- [1] Dr. S. J. Lacey, Engineering Manager Schaeffler (UK) Limited, "The Role of Vibration Monitoring in Predictive Maintenance"
- [2] R.Megala1, Dr. V.Eswaramoorthy, "fault detection and prediction of failure using vibration analysis", International Research Journal of Engineering and Technology (IRJET), Volume: 05 Issue: 06 | June-2018.
- [3] Vishal Pande "Predictive Maintenance For Hydraulic System" in International Journal of Engineering Research and Application, volume-9 Issue No 5, Series-I May 2019.
- [4] "Handbook of Modern Sensors – 4th edition", by Jacob Fraden
- [5] "Remote Access of Control Loop Trainer kit using GNU Radio in Real Time." In IJERA Journal special issue, VNCET'12. By Shiva Agrawal, Pushkar Bhawe, Nishigandh Vartak, Chitra Chopde, Vishal Pande, Prafulla Patil.
- [6] PSG data book.
- [7] "Automation in Paper Cutting Machine" In IJESC Journal, Vol. 9, Apr.2019 by Prafulla V. Patil, Pratik. S. Gajbiye, Siddhesh. S. Mahagaonkar, Amey. J. Churi, Manoj. D. Ambadkar
- [8] "Strength of Material- 3rd edition", Elementary Theory and Problems by Stephen Timoshenko.
- [9] "Predictive Maintenance of Machine Tool Systems Using Artificial Intelligence Techniques Applied to Machine Condition Data", Wo Jae Leea., Haiyue Wu, Huitaek Yun, Hanjun Kim, Martin B.G. Jun, John W. Sutherland, 26th CIRP Life Cycle Engineering (LCE) Conference
- [10] Wuest T, Weimer D, Irgens C, Thoben K-D. Machine learning in manufacturing: advantages, challenges, and applications. Prod Manuf Res 2016;4:23–45. doi:10.1080/21693277.2016.1192517.
- [11] "Application of Artificial Intelligence in Maintenance Modelling and Management", Khairy A H Kobbacy, 2nd IFAC Workshop on Advanced Maintenance Engineering, Services and Technology, Universidad de Sevilla, Sevilla, Spain. November 22-23, 2012.
- [12] "Artificial intelligence for fault diagnosis of rotating machinery", Ruonan Liu, Boyuan Yang, Enrico Zio, Xuefeng Chen, State Key Laboratory for Manufacturing Systems Engineering, Xian Jiaotong University, Xi'an 710049, China.
- [13] Y. Lei, M.J. Zuo, Gear crack level identification based on weighted k nearest neighbor classification algorithm, Mech. Syst. Sign. Process. 23 (5) (2009) 1535–1547.
- [14] V. Muralidharan, V. Sugumaran, A comparative study of Naïve Bayes classifier and Bayes net classifier for fault diagnosis of monoblock centrifugal pump using wavelet analysis, Appl. Soft Comput. 12 (8) (2012) 2023–2029.
- [15] "Multinomial Naive Bayes Classification Model for Sentiment Analysis", Muhammad Abbas, Kamran Ali Memon, Abdul Aleem Jamali, Saleemullah Memon, Anees Ahmed, IJCSNS International Journal of Computer Science and Network Security, VOL.19 No.3, March 2019.
- [16] "Comparative study of measurement systems used to evaluate vibrations of rolling bearings", Stanisław Adamczak, Krzysztof Stepień, Mateusz Wrzochala, Procedia Engineering 192 (2017) 971–975.