

# Comparative study on Predictive Current Control and Space Vector Modulation Techniques of Direct Matrix Converter in Wind Energy Conversion System

Vineet Dahiya<sup>1</sup>

<sup>1</sup>. Assistant Professor,  
K R Mangalam University,  
Gurugram and Presently Research Scholar in  
EEE Department  
Manav Rachna International University.  
Faridabad.

Leena G.<sup>2</sup>

<sup>2</sup>. Professor,  
EEE Department,  
Manav Rachna International University,  
Faridabad.

**Abstract:** The objective of the paper is to compare two control techniques commonly being used like predictive current control and space vector modulation in Direct Matrix Converter. These two methods are compared considering theoretical complexity and performance. The purpose of most of these methods is to generate sinusoidal currents on both input and output side. The space vector Modulation (SVM) approach is based on instantaneous space vector representation of input and output voltages and current. Due to advances in processors Predictive Control Schemes have recently emerged as feasible approaches. This strategy uses the converter and load model to predict the future behavior of load currents and power.

**Keywords:** Wind Energy Conversion System (WECS), Direct Matrix Converter (DMC), Space vector Modulation (SVM), Predictive Current Control(PCC).

## I. INTRODUCTION

Nowadays, wind energy conversion has acquired a mature technology and provides a clean and inexhaustible source of energy for maintaining the continuously growing energy requirements of humanity. Wind Energy Conversion System uses Direct Matrix Converter (DMC) for transfer of power. The Matrix Converter (MC) is an ac-to-ac direct power conversion system that can generate variable voltage, variable frequency output from the ac power source. Since the introduction of MC concept by Venturini in 1980[1], this technology has been widely studied

Years of continuous and dedicated efforts have been made for the development of modulation and control strategies that can be applied to MC's. The first and highly relevant method is called direct transfer function approach also known Venturini method. Here, the output voltage is obtained by the product of the input voltage and the transfer matrix representing the convertor. Second method was developed by Roy, which consists of using instantaneous voltage ratio of specific input voltages so as to generate the active and zero states of convertor's switches. Then the simplest approach came in the form of carrier-based PWM techniques. Further modification in controlled techniques

led to a very elegant and powerful solution that is space vector modulation (SVM) in MCs. Now a days predictive controlled techniques have been proposed for the current and torque control of AC machines using MCs[2,8,9]. This paper compares predictive current control (PCC) and space vector modulation (SVM) techniques in terms of theoretical complexities, quality of load current, dynamic response, sampling frequency, switching frequency and resonance of input filter.

Section I describes the configuration and switching techniques of DMC. Section II describes space vector modulation (SVM) method in MCs. Section III describes predictive current control (PCC) method. Section IV describes the comparative analysis between the two methods. Section V draws conclusions.

### 1. Direct Matrix Converter(DMC)

The Matrix Converter is a forced commutated converter which uses an array of controlled bi-directional switches as the main power elements to create a variable output voltage system with unrestricted frequency. It does not have any dc-link circuit and does not need any large energy storage elements.

The key element in a Matrix Converter is the fully controlled four-quadrant bidirectional switch, which allows high frequency operation. The early work dedicated to unrestricted frequency changers used thyristors with external forced commutation circuits to implement the bi-directional controlled switch. With this solution the power circuit was bulky and the performance was poor[3,4].

The introduction of power transistors for implementing the bi-directional switches made the Matrix Converter topology more attractive in 1980s [1].

The Matrix Converter is a single stage converter which has an array of  $m \times n$  bidirectional power switches to connect, directly, an  $m$ -phase voltage source to an  $n$ -phase load. The Matrix Converter of  $3 \times 3$  switches, shown in figure 1, has

the highest practical interest because it connects a three-phase voltage source with a three-phase load, typically a motor.

Normally, the Matrix Converter is fed by a voltage source and for this reason the input terminals should not be short-circuited. On the other hand, the load has typically an inductive nature and for this reason an output phase must never be opened.

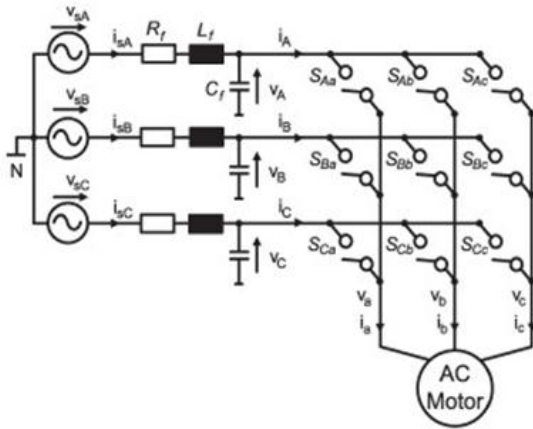

Fig.1 DMC Topology

Defining the switching function of a single switch as:

$$S_{kj} = \begin{cases} 1, \text{switch } S_{kj} \text{ closed} \\ 0, \text{switch } S_{kj} \text{ open} \end{cases} \quad (1)$$

The constraints discussed above can be expressed by :

$$S_{Aj} + S_{Bj} + S_{Cj} = 1 \quad (2)$$

With these restrictions, the 3x3 Matrix Converter has 27 possible switching states. The load and source voltages are referenced to the supply neutral, "0" in figure 1, and can be expressed as vectors defined by:

$$v_o = \begin{bmatrix} v_a(t) \\ v_b(t) \\ v_c(t) \end{bmatrix}; v_i = \begin{bmatrix} v_A(t) \\ v_B(t) \\ v_C(t) \end{bmatrix} \quad (3)$$

The relationship between load and input voltages can be expressed as:

$$\begin{bmatrix} v_a(t) \\ v_b(t) \\ v_c(t) \end{bmatrix} = \begin{bmatrix} S_{Aa}(t) S_{Ba}(t) S_{Ca}(t) \\ S_{Ab}(t) S_{Bb}(t) S_{Cb}(t) \\ S_{Ac}(t) S_{Bc}(t) S_{Cc}(t) \end{bmatrix} \begin{bmatrix} v_A(t) \\ v_B(t) \\ v_C(t) \end{bmatrix} \quad (4)$$

$$v_o = T v_i$$

where T is the transfer matrix. In the same form as that of voltage, the relationships are valid for the input and output currents.

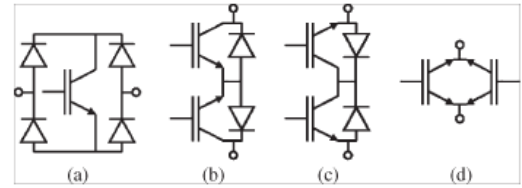

Fig.2 Possible bidirectional switch configuration (a) DB arrangement (b)CE arrangement(c)CC arrangement(d)RB-IGBT arrangement.

Now a day's most matrix converter application uses IGBT devices and diodes to create the power circuit instead of using MOSFET, GTO earlier because of latter's low power application and low switching frequency. The reverse blocking IGBT (RB-IGBT) is also gaining popularity recently as antiparallel diodes can be eliminated from the converters as seen from fig.2.

In DMC there are various control and modulation techniques out of which SVM and PCC are described and compared here

## II. SPACE VECTOR MODULATION (SVM)

Among the 27 possible switching configurations available in three phase MCs only 21 are useful out of which first 18 switching configurations determine an output voltage vector and input current vector having fixed directions. While the last three switching configurations determine zero input current and output voltage vectors. So in building SVM algorithm 21 switching configurations are useful of which first 18 determine an output voltage vector and input current vector with fixed directions [4,5,6,7].

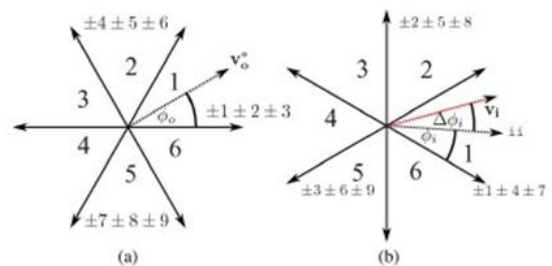

Fig.3 DMC vectors for SVM (a) voltage vectors.(b) current vectors.

The magnitude of these vectors depends upon the instantaneous values of the input voltages and the output line currents respectively. Zero input current and output voltage vectors are given by last three switching configurations. In SVM algorithm for MCs there is capability to achieve full control of both the output voltage vector and the instantaneous input current displacement angle.

Output voltage vector and input current displacement angle are called as reference quantities at any given sampling angle. The source voltages imposes input line-to-neutral voltage vector which can be assimilate by its measurements. Hence by controlling the phase angle of the input current vector control of input side can be achieved and by considering the duty cycles both input current and output voltage vectors are synthesized. The duty cycles are

calculated as shown in fig.2 which is based on the phase of output voltage and input current vector references given by equations:

$$\delta_1 = -1^{k_v+k_i+1} \frac{2m \cos(\phi'_o - \pi/2) \cos(\phi'_i - \pi/2)}{\sqrt{3} \cos(\Delta\phi)} \quad (5)$$

$$\delta_2 = -1^{k_v+k_i+1} \frac{2m \cos(\phi'_o - \pi/2) \cos(\phi'_i + \pi/6)}{\sqrt{3} \cos(\Delta\phi)} \quad (6)$$

$$\delta_3 = -1^{k_v+k_i+1} \frac{2m \cos(\phi'_o + \pi/6) \cos(\phi'_i - \pi/2)}{\sqrt{3} \cos(\Delta\phi)} \quad (7)$$

$$\delta_4 = -1^{k_v+k_i+1} \frac{2m \cos(\phi'_o + \pi/6) \cos(\phi'_i + \pi/6)}{\sqrt{3} \cos(\Delta\phi)} \quad (8)$$

Here  $m$  represents modulation index and  $\Delta\phi$  is the displacement angle between the measured input voltages vector  $v_i$  and the input current reference vector.  $k_v$  and  $k_i$  represents voltage and current factors[9-23].

$\phi'_o$  and  $\phi'_i$  can be defined by following equations:

$$\phi'_o = \phi_o - (k_v - 1)\pi/6, \phi'_i = \phi_i - (k_i - 1)\pi/6 \quad (9)$$

The name of the switching state which is to be applied has a negative sign if the sign of any duty cycle is negative. The duty cycle at a fixed sampling frequency is equivalent to the unit of zero vector as

$$\delta_o = 1 - \delta_1 - \delta_2 - \delta_3 - \delta_4. \quad (10)$$

When  $\Delta\phi=0$ , the maximum modulation index  $m = \sqrt{3}/2$

### III. PREDICTIVE CURRENT CONTROL (PCC)

In Predictive control scheme there is converters switching state selection which culminates the controlled variables to their nearest respective references at the end of the sampling period. In this method converter and load models are used which tell future behavior of load currents and reactive power [24-25].

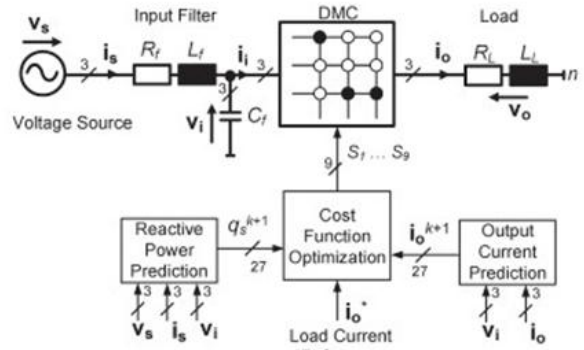

Fig .4 PCC scheme

A simple functional time continuous model of the load side can be described as

$$L \frac{di_o}{dt} = v_o - R_L i_o \quad (11)$$

From Fig 3 state variable model of the ac-input is given as

$$L_f \frac{di_s}{dt} = v_s - v_i - R_f i_s \quad (12)$$

$$C_f \frac{dv_i}{dt} = i_s - i_i \quad (13)$$

Future load current to be predicted by first order discrete approximation as:

$$i_o(k+1) = T_s v_o(k+1) + L_L i_o \frac{(k)}{L} + R_L T_s \quad (14)$$

Equations on the input side represents a second order model, the supply current in sampling period  $k+1$  predicts the future behavior whose expression is given by:

$$i_s(k+1) = c_1 v_s(k) + c_2 v_i(k) + c_3 i_s(k) + c_4 i_i(k) \quad (15)$$

The line side of converter has minimized reactive power and good accuracy of load currents are the two conditions of the converter to operate properly. Both the requirements can be merged into a single quality function  $g$  as:

$$g = \Delta i_o(k+1) + A \Delta q_s(k+1) \quad (16)$$

where first term gives comparison between the reference load currents and the predicted ones whereas second one corresponds to the predicted reactive power, both in  $\alpha \beta$  components.

All 27 possible switching states are used to determine predicted values of load and input current, which will evaluate function  $g$  at each sampling time, after which switching state with minimum value of  $g$  is selected for the next modulation period. When the value of weighting factor  $A$  is increased and becomes 1 from zero load current is sinusoidal and input reactive power is zero which eliminates the resonance of input filter and hence quality of input current [26-37].

#### IV. COMPARISON BETWEEN SVM AND PCC METHODS

This section describes the comparative analysis between the above described techniques. The comparison is carried out by analysis of following parameters: - Complexity of the circuit, sampling frequency, switching frequency, dynamic response and resonance input filter. The analysis is done in tabular form given below

TABLE -1

Technical Features	SVM	PCC
Complexity	Very high	Low
Sampling Frequency	Low	High
Switching Frequency	Low	High
Dynamic Response	Good	Very Fast
Resonance input filter	Low	From very high to low

As seen from the above table Predictive Control Scheme (PCC) appears to be more promising scheme than space Vector Modulation Technique (SVM) due to its simplicity and flexibility apart from its aspects in the control. In Predictive control strategy there is minimized reactive power flow between rotor and grid side if we are applying this scheme on generators in wind energy conversion systems. The control scheme is simple and powerful as it uses discrete model of the converter in predicting the behavior of the system. The complexity of circuit in PCC scheme is simple as compared to SVM as seen from fig.4.

#### V. CONCLUSION.

The two methods described here both have their own pros and cons. Predictive current control (PCC) method is more effective in terms of complexity, sampling frequency, switching frequency, dynamic response and resonance input filter. PCC appears as the most promising alternative out of above said two methods because of its simplicity and flexibility to include additional aspects in the control. Another method Predictive Torque Control (PTC) also uses 27 feasible states of the DMC and is analogous to PCC, while SVM uses 21 feasible states out of which 18 switching configurations are there for use. A lot of deeper research is going on in the area of modulation and control strategies of DMCs in terms of losses, system integration, electromagnetic comp ability etc.

#### REFERENCES:

[1] E. Yamamoto, T. Kume, H. Hara, T. Uchino, J. Kang, and H. Krug, "Development of matrix converter and its applications in industry," in Proc. 35th IEEE IECON, Porto, Portugal, 2009, pp. 4–12.

[2] Marco Rivera, Student Member, IEEE, José Rodríguez, Fellow, IEEE, Patrick W. Wheeler, Member, IEEE, Christian A. Rojas, Student Member, IEEE, Alan Wilson, Member, IEEE, and José R. Espinoza, Member, IEEE. "Control of a Matrix Converter With Imposed Sinusoidal Source Currents." IEEE TRANSACTIONS ON INDUSTRIAL ELECTRONICS, VOL. 59, NO. 4, APRIL 2012.

[3] O. Simon, J. Mahlein, M. Muenzer, and M. Bruckmarm, "Modern solutions for industrial matrix-converter applications," IEEE Trans. Ind. Electron., vol. 49, no. 2, pp. 401–406, Apr. 2002.

[4] D. Casadei, G. Serra, A. Tani, and L. Zarri, "Matrix converter modulation strategies: A new general approach based on space-vector representation of the switch state," IEEE Trans. Ind. Electron., vol. 49, no. 2, pp. 370–381, Apr. 2002.

[5] L. Helle, K. Larsen, A. Jorgensen, S. Munk-Nielsen, and F. Blaabjerg, "Evaluation of modulation schemes for three-phase to three-phase matrix converters," IEEE Trans. Ind. Electron., vol. 51, no. 1, pp. 158–171, Feb. 2004.

[6] D. Casadei, G. Serra, A. Tani, and L. Zarri, "A novel modulation strategy for matrix converters with reduced switching frequency based on output current sensing," in Proc. 35th Annu. IEEE Power Electron. Spec. Conf., Jun. 2004, vol. 3, pp. 2373–2379.

[7] S. Pinto and J. Silva, "Direct control method for matrix converters with input power factor regulation," in Proc. 35th Annu. IEEE Power Electron. Spec. Conf., Jun. 2004, vol. 3, pp. 2366–2372.

[8] M. Jussila, M. Salo, and H. Tuusa, "Induction motor drive fed by a vector modulated indirect matrix converter," in Proc. 35th Annu. IEEE Power Electron. Spec. Conf., 2004, vol. 4, pp. 2862–2868.

[9] L. Wang, D. Zhou, K. Sun, and L. Huang, "A novel method to enhance the voltage transfer ratio of matrix converter," in Proc. IEEE TENCON, Nov. 2004, vol. 4, pp. 81–84.

[10] K.-B. Lee and F. Blaabjerg, "Reduced-order extended Luenberger observer based sensorless vector control driven by matrix converter with nonlinearity compensation," IEEE Trans. Ind. Electron., vol. 53, no. 1, pp. 66–75, Feb. 2006.

[11] M. Jussila and H. Tuusa, "Space-vector modulated indirect matrix converter under distorted supply voltage—Effect on load current," in Proc. IEEE 36th Power Electron. Spec. Conf., Jun. 2005, pp. 2396–2402.

[12] F. Gao and M. Iravani, "Dynamic model of a space vector modulated matrix converter," IEEE Trans. Power Del., vol. 22, no. 3, pp. 1696–1705, Jul. 2007.

[13] M. Jussila and H. Tuusa, "Comparison of simple control strategies of space-vector modulated indirect matrix converter under distorted supply voltage," IEEE Trans. Power Electron., vol. 22, no. 1, pp. 139–148, Jan. 2007.

[14] S. Kwak, T. Kim, and O. Vodyakho, "Space vector control methods for two-leg and three-leg based AC to AC converters for two-phase drive systems," in Proc. 34th IEEE IECON, Nov. 2008, pp. 959–964.

[15] H.-H. Lee, H. Nguyen, and T.-W. Chun, "New direct-SVM method for matrix converter with main input power factor compensation," in Proc. 34th IEEE IECON, Nov. 2008, pp. 1281–1286.

[16] D. Casadei, G. Serra, A. Tani, and L. Zarri, "Optimal use of zero vectors for minimizing the output current distortion in matrix converters," IEEE Trans. Ind. Electron., vol. 56, no. 2, pp. 326–336, Feb. 2009.

[17] H. She, H. Lin, X. Wang, and S. Xiong, "Space vector modulated matrix converter under abnormal input voltage conditions," in Proc. 6th IEEE IPEMC, May 2009, pp. 1723–1727.

[18] F. Bradaschia, E. Ibarra, J. Andreu, I. Kortabarria, E. Ormaetxea, and M. Cavalcanti, "Matrix converter: Improvement of the space vector modulation via a new double-sided generalized scalar PWM," in Proc. 35th IEEE IECON, Nov. 2009, pp. 4511–4516.

[19] H. Nguyen, H.-H. Lee, and T.-W. Chun, "An investigation on direct space vector modulation methods for matrix converter," in Proc. 35th IEEE IECON, Nov. 2009, pp. 4493–4498.

[20] E. Ibarra, J. Andreu, I. Kortabarria, E. Ormaetxea, and E. Robles, "A fault tolerant space vector modulation strategy for matrix converters," in Proc. 35th IEEE IECON, Nov. 2009, pp. 4463–4468.

[21] R. Cardenas-Dobson, R. Pena, P. Wheeler, and J. Clare, "Experimental validation of a space vector modulation algorithm for four-leg matrix converters," IEEE Trans. Ind. Electron., vol. 58, no. 4, pp. 1282–1293, Apr. 2011.

[22] M. Nguyen, H. Lee, and T. Chun, "Input power factor compensation algorithms using a new direct-SVM method for matrix converter," IEEE Trans. Ind. Electron., vol. 58, no. 1, pp. 232–243, Jan. 2011.

[23] M. Y. Lee, P. Wheeler, and C. Klumpner, "Space-vector modulated multilevel matrix converter," IEEE Trans. Ind. Electron., vol. 57, no. 10, pp. 3385–3394, Oct. 2010.

[24] E. Ormaetxea, J. Andreu, I. Kortabarria, U. Bidarte, Martinez de Alegria, E. Ibarra, and E. Olaguegana, "Matrix converter protection and computational capabilities based on a system on chip design with an FPGA," IEEE Trans. Power Electron., vol. 26, no. 1, pp. 272–287, Jan. 2011.

[25] M. Rivera, R. Vargas, J. Espinoza, J. Rodriguez, P. Wheeler, and C. Silva, "Current control in matrix converters connected to polluted AC voltage supplies," in Proc. IEEE Power Electron. Spec. Conf., Jun. 2008 pp. 412–417.

- [26] R. Vargas, J. Rodriguez, U. Ammann, and P. Wheeler, "Predictive current control of an induction machine fed by a matrix converter with reactive power control," *IEEE Trans. Ind. Electron.*, vol. 55, no. 12, pp. 4362–4371, Dec. 2008.
- [27] R. Vargas, U. Ammann, J. Rodriguez, and J. Pontt, "Predictive strategy to control common-mode voltage in loads fed by matrix converters," *IEEE Trans. Ind. Electron.*, vol. 55, no. 12, pp. 4372–4380 Dec. 2008.
- [28] R. Vargas, U. Ammann, and J. Rodriguez, "Predictive approach to increase efficiency and reduce switching losses on matrix converters," *IEEE Trans. Power Electron.*, vol. 24, no. 4, pp. 894–902, Apr. 2009.
- [29] F. Morel, J.-M. Retif, X. Lin-Shi, B. Allard, and P. Bevilacqua, "A predictive control for a matrix converter-fed permanent magnet synchronous machine," in *Proc. IEEE Power Electron. Spec. Conf.*, Jun. 2008, pp. 15–21.
- [30] P. Gamboa, J. Silva, S. Pinto, and E. Margato, "Predictive optimal matrix converter control for a dynamic voltage restorer with flywheel energy three-phase induction machine," *IEEE Trans. Ind. Electron.*, vol. 56, no. 6, pp. 1974–1983, Jun. 2009.
- [31] P. Correa, J. Rodriguez, M. Rivera, J. Espinoza, and J. Kolar, "Predictive control of an indirect matrix converter," in *IEEE Trans. Ind. Electron.*, Jun. 2009, vol. 56, no. 6, pp. 1847–1853.
- [32] M. Rivera, P. Correa, J. Rodriguez, I. Lizama, and J. Espinoza, "Predictive control of the indirect matrix converter with active damping," in *Proc. 6th IEEE IPEMC*, May 2009, pp. 1738–1744.
- [33] Y. Li, N.-S. Choi, H. Cha, and F. Peng, "Carrier-based predictive current controlled pulse width modulation for matrix converters," in *Proc. 6th IEEE IPEMC*, May 2009, pp. 1009–1014.
- [34] J. Rodriguez, J. Kolar, J. Espinoza, M. Rivera, and C. Rojas, "Predictive current control with reactive power minimization in an indirect matrix converter," in *Proc. IEEE ICIT*, Mar. 2010, pp. 1839–1844.
- [35] R. Vargas, J. Rodriguez, C. Rojas, and P. Wheeler, "Predictive current control applied to a matrix converter: An assessment with the direct transfer function approach," in *Proc. IEEE ICIT*, Mar. 2010, pp. 1832–1838.
- [36] J. Rodriguez, J. Espinoza, M. Rivera, F. Villarroel, and C. Rojas, "Predictive control of source and load currents in a direct matrix converter," in *Proc. IEEE ICIT*, Mar. 2010, pp. 1826–1831.
- [37] J. Rodriguez, J. Pontt, R. Vargas, P. Lezana, U. Ammann, P. Wheeler, and F. Garcia, "Predictive direct torque control of an induction motor fed by a matrix converter," in *Proc. Eur. Conf. Power Electron. Appl.*, Sep. 2007, pp. 1–10. storage," in *Proc. 35th IEEE IECON*, Nov. 2009, pp. 759–764.