

# Check post and Toll Tax Collection using RFID

Yogesh Kamble<sup>1</sup>, Ajinkya Abhyankar<sup>2</sup>, TanmayPradhan<sup>3</sup>, AdityaThorat<sup>4</sup>, Prof Trupti harhare<sup>5</sup>

<sup>#</sup>LokmanyaTilak College of Engineering, Navi Mumbai

<sup>1</sup>yogeshkamble105@gmail.com, <sup>2</sup>ajinkyamabhyankar@gmail.com, <sup>3</sup>tanmay.pradhan@gmail.com

<sup>4</sup>aditya123thorat@gmail.com, <sup>5</sup>mtruptis@gmail.com

## Abstract—

The main purpose of this concept is to catch the stolen vehicles by a latest technology. This research work is developing a smart logic to identify the stolen vehicle on check post or Toll base. Still there is no technique to identify the vehicle on check posts by any mean. To employ this technology in use, we issue one unique identification code (UID) to every vehicle. This unique number is stored in the silicon chip and the chip is installed in the vehicle. No one can change this number because this UID chip is installed in the engine of the vehicle. This vehicle number is not available in the market. Now the vehicle is equipped with the UID code. This code is also stored in the Data base of check post or Toll base. Now when any vehicle passed through the check post/Toll then at the check post/Toll RF passive vehicle reader generates a 125 kHz frequency for decoding RF tag (which has been installed in the vehicle). If the data base does not find the stolen UID code then security gate gets OPEN and if the stolen UID code is matched with the data base then security gate remains closed and alarm becomes ON automatically and finally the stolen vehicle is caught.

**Keywords—** RFID principles, advantages, limitations, applications.

## I. INTRODUCTION

The modernization of transport has become one of the essential signs for the urban modernization level, the increase in the number of cars leads to serious problems concerning transport system. With the development of the technology of computer, communication, electron, information and intelligence has become important factors in achieving convenient and efficient transport system. According to these circumstances, the Intelligent Transport System (ITS) came into existence [1]. Collection of transportation information systems based on conventional detection techniques such as loop detectors, video image processing, and Dedicated Short Range Communication (DSRC) leads to high installation and maintenance costs, the high costs prevented the proliferation of these detection techniques [2]. Radio Frequency Identification (RFID) technology is one of the most rapidly growing segments of today's Automatic Identification Data Collection (AIDC) industry [3]. Using "RFID tags" on objects or assets, and "RFID readers" to gather the tag information, RFID represents an improvement over bar codes in terms of non-optical proximity communication, information density, and two-way communication ability. It can automatically identify target and obtain relevant data without contacting with the target. It has many advantages such as high precision, easy adapting ability and quickly operation and so on. Moreover, it is able to work under harsh environment and reads from long distance [4]. Automatic Vehicles

Identification (AVI) system based on RFID is design for all legally registered vehicles; these vehicles must hold RFID tags. When these vehicles travel along a road or intersection which is installed AVI system (RFID reader), the information of vehicle tag is read and sent immediately to Center Computer System (CCS) for achieving the purpose of real-time monitoring and management for vehicle movement conditions. The CCS receives the information and position of the vehicle from traffic intersection and then analyzes and filters to store it in database

## II. THEORY

RFID technology is currently being used in numerous applications throughout the world [3]. RFID is not a new technology, for example, the principles of RFID has been employed by the British in World War II to identify their aircraft using the IFF system (Identity: Friend or Foe) and it is still being used today for the same purposes. RFID uses tags to transmit data upon RFID reader queries. RFID tag responds to a reader query with its fixed unique serial number (tag ID). This fixed tag ID enables tracking of tags and the bearers. In addition to the unique serial number, some tags carry information about the objects they are attached to RFID is used for a wide variety of applications ranging from the familiar building access control proximity cards to supply chain tracking, toll collection, vehicle parking access control, retail stock management, tracking library books, theft prevention, etc.

### A. RFID System Components

RFID is a generic term for technologies that use radio waves to automatically identify people or objects. There are several methods of identification, the most common of which is to associate the RFID tag unique identifier with an object or person. RFID system (as shown in Fig1) will typically comprise the following [4]:

- RFID tag.
- RFID reader with an antenna and transceiver.
- A host system or connection to an enterprise system.

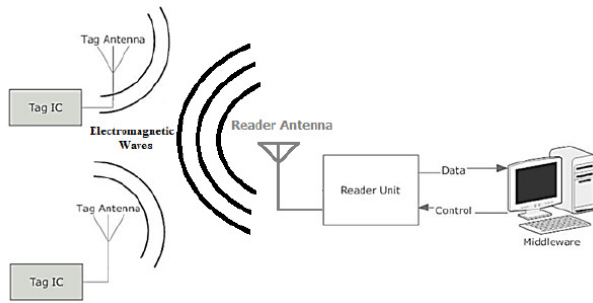

Figure 1. Components of RFID system

### B. RFID Tags

The tag, also known as the transponder (derived from the terms transmitter and responder), holds the data that is transmitted to the reader when the tag is interrogated by the reader. The most common tags today consist of an Integrated Circuit (IC) with memory, essentially a microprocessor chip, see Fig.2.

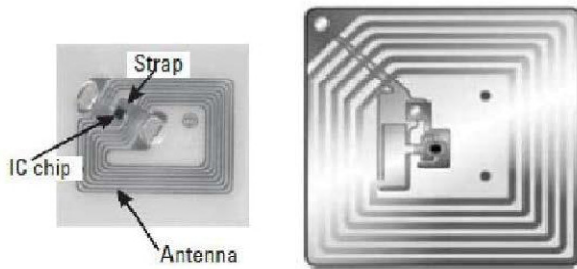

Figure 2. Typical design of passive tag

The implementation of a passive UHF RFID tag is shown in Fig.3, a block diagram of RFID tag using back scatter modulation. The tag consists of tag antenna and tag chip. The tag chip contains a RF-analog front end (voltage rectifier, clock generator, modulator and demodulator), a digital control block, and a non-volatile memory.

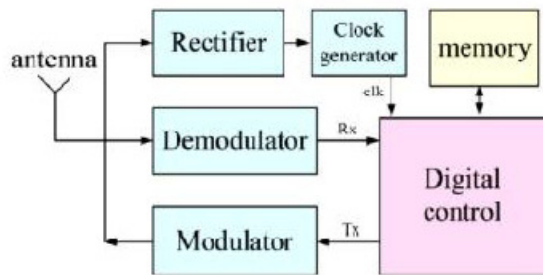

Figure 3. Passive UHF RFID tag block diagram

Other tags are chip less and have no onboard IC. Chip less tags are most effective in applications where simpler range of functions is required; although they can help achieve more accuracy and better detection range, at potentially lower cost than their IC-based counterparts. When a tag is interrogated, the data from its memory is retrieved and transmitted. A tag

can perform basic tasks (read/write from/to memory) or A tag can perform basic tasks (read/write from/to memory) or manipulate the data in its memory in other ways. RFID tags can interfere with each other. When multiple tags are present in a reader's field, the reader may be unable to decipher the signals from the tags. For many applications, such as raising the gate in a parking lot, this is not a problem. The systems are optimized so that only one tag is within range at a time.

### C. RFID Reader

Reader, as a scanning device, detects the tags that attached to or embedded in the selected items. It varies in size, weight and may be stationary or mobile. Reader communicates with the tag through the reader antenna, which broadcasting radio waves and receiving the tags response signals within its reading area. After the signals from tags are detected, reader decodes them and passes the information to middleware. The reader for a read/write tag is often called an interrogator. Unlike the reader for a read- only tag, the interrogator uses command pulses to communicate with a tag for reading and writing data [3]. RFID reader sends a pulse of radio energy to the tag and listens for the tag's response. The tag detects this energy and sends back a response that contains the tag's serial number and possibly other information as well. Historically, RFID readers were designed to read only a particular kind of tag, but so-called multimode readers that can read many different kinds of tags are becoming increasingly popular. Like the tags themselves, RFID readers come in many sizes. The largest readers might consist of a desktop personal computer with a special card and multiple antennas connected to the card through shielded cable. Such a reader would typically have a network connection as well so that it could report tags that it reads to other computers. The smallest readers are the size of a postage stamp and are designed to be embedded in mobile telephones.

### D. RFID Antenna

The reader antenna establishes a connection between the reader electronics and the electromagnetic wave in the space. In the HF range, the reader antenna is a coil (like the tag antenna), designed to produce as strong a coupling as possible with the tag antenna. In the UHF range, reader antennas (like tag antennas) come in a variety of designs. Highly directional, high-gain antennas are used for large read distances [3]. Antenna design and placement plays a significant factor in determining the coverage zone, range and accuracy of communication. Physical interdependencies mean that the antenna gain is linked to the antenna size.

### E. RFID Middleware

A middleware, as the name suggests, is a piece of software that lies between a lower layer processing device or software and an upper layer server or software, usually at the application level. Therefore, data from RFID readers are sent to a middleware platform that acts as a bridge between RFID

readers and host application software. Typically, RFID middleware platform performs aggregation of data across different readers, filtering of unwanted or noisy RFID data, forwarding of relevant data to subscriber servers or application-level systems, and persistent storage for context aware and other added value services. However, RFID middleware is often given the task of managing, monitoring and configuring the different readers and interrogators. The middleware performs monitoring task on RFID readers to check operational status of the readers. This is a very important function, especially when readers are located in distributed manner, and manual monitoring is impractical.

#### F. Automatic Vehicles Identification (AVI) based on RFID

AVI system based on RFID is a design that covers every vehicle legally registered which carries RFID tag. When these vehicles travel along a road in which AVI system is installed, all kinds of vehicles information of car tag is read and transmitted in real-time to data processing controlling unit realizing the purpose of real-time monitor and management for vehicle operating conditions. The main components of the AVI system based on RFID include: (i) hardware, i.e. passive RFID tags and readers for generation of traffic information; (ii) RFID middleware and database structure, and application software consisting of real-time process; and (iii) network architecture to deploy AVI system nationwide.

### III. ADVANTAGES AND LIMITATIONS OF THE TECHNOLOGY

#### A. Advantages

Though RFID is not likely to entirely replace commonly used barcodes in the near future, the following advantages suggest to additionally applying RFID for added value of identification:

- Tag detection not requiring human intervention reduces employment costs and eliminates human errors from data collection,
- As no line-of-sight is required, tag placement is less constrained,
- RFID tags have a longer read range than, e. g., barcodes.
- Tags can have read/write memory capability, while barcodes do not.
- An RFID tag can store large amounts of data additionally to a unique identifier,
- Unique item identification is easier to implement with RFID than with barcodes,
- Tags are less sensitive to adverse conditions (dust, chemicals, physical damage etc.),
- Many tags can be read simultaneously,
- RFID tags can be combined with sensors,
  - Automatic reading at several places reduces time lags and inaccuracies in an inventory
- Tags can locally store additional information; such distributed data storage may increase fault tolerance of the entire system,
- Reduces inventory control and provisioning costs,

- Reduces warranty claim processing costs.

#### B. Current issues of concern, limitations

Although many RFID implementation cases have been reported, the widespread diffusion of the technology and the maximum exploitation of its potential still requires technical, process and security issues to be solved ahead of time. Today's limitations of the technology are foreseen to be overcome and specialists are already working on several of these issues.

##### 1) Standardization

Though the characteristics of the application and the environment of use determine the appropriate tag, the sparse standards still leave much freedom in the choice of communication protocols and the format and amount of information stored in the tag. Companies transcending a closed-loop solution and wishing to share their application with others may encounter conflicts as cooperating partners need to agree in standards concerning communication protocols, signal modulation types, data transmission rates, data encoding and frames, and collision handling algorithms. Currently, two major groups of standards are competing worldwide: one is EPC created by the Auto-ID Center and receiving the support of UCC (Uniform Code Council) and EAN (European Article Numbering), the other is the ISO-specified (International Standards Organization) set of standards.

### TOLL COLLECTION

Electronic toll collection (ETC) is a technology enabling the electronic collection of toll payments. It has been studied by researchers and applied in various highways, bridges, and tunnels requiring such a process. This system is capable of determining if the car is registered or not, and then informing the authorities of toll payment violations, debits, and participating accounts. The most obvious advantage of this technology is the opportunity to eliminate congestion in tollbooths, especially during festive seasons when traffic tends to be heavier than normal. It is also a method by which to curb complaints from motorists regarding the inconveniences involved in manually making payments at the tollbooths. Other than this obvious advantage, applying ETC could also benefit the toll operators.

The benefits for the motorists include:

1. Fewer or shorter queues at toll plazas by increasing toll booth service turnaround rates;
  2. Faster and more efficient service (no exchanging toll fees by hand);
  3. The ability to make payments by keeping a balance on the card itself or by loading a registered credit card; and
  4. The use of postpaid toll statements (no need to request for receipts). Other general advantages for the motorists include fuel savings and reduced mobile emissions by reducing or eliminating deceleration, waiting time, and acceleration.
- Meanwhile, for the toll operators, the benefits include:

5. Lowered toll collection costs;
6. Better audit control by centralized user accounts; and
7. Expanded capacity without building more infrastructures.

**A. Canada**

The ETC system used in Canada is known as the Canada 407 Express toll route (ETR). It is one of the most sophisticated toll roads in the world. The Canada 407 ETR is a closed-access toll road, which means that there are gantries placed at the entrance and exit points of each toll. In this system, cameras are equipped with Optical Character Recognition (OCR). The OCR cameras are used to photograph license plate numbers of vehicles that do not have transponders. The toll bill will then be sent directly to the registered address of the vehicle owners. Other than that, two laser beam scanners are placed above the roadway to detect the types of vehicles passing through the gantries. Nevertheless, this toll road bears a very high infrastructure cost, and the users are the ones who help recover the cost through increments in their toll bills

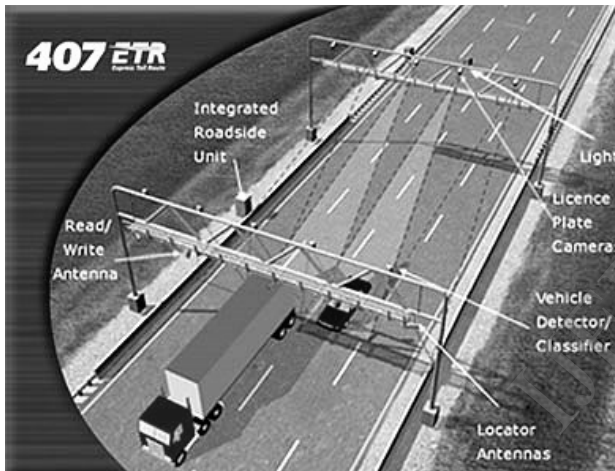

**B. Poland**

The ETC system used in Poland has been proposed by the Motor Transport Institute along with the University of Technology in Warsaw and Dublin. This system is called the National Automatic Toll Collection System (NATCS), and consists of the National Automatic Toll Collection Center (NATCC), control gates, and on-board units (OBU). The NATCS uses a combination of mobile telecommunication technology (GSM) with satellite-based Global Positioning System (GPS). Using GPS technology, the OBUs determine the kilometers that have been driven, calculate the toll fees and rates, and then transmit the information to the NATCS computer center. Each vehicle will be charged from the highway entrance up until the end of the highway. In order to identify the plate numbers of trucks, the system has control gates equipped with digital short range communication (DSRC) detection equipment and high resolution cameras.

Due to the technical specifications, this system incurs a high cost for motorists.

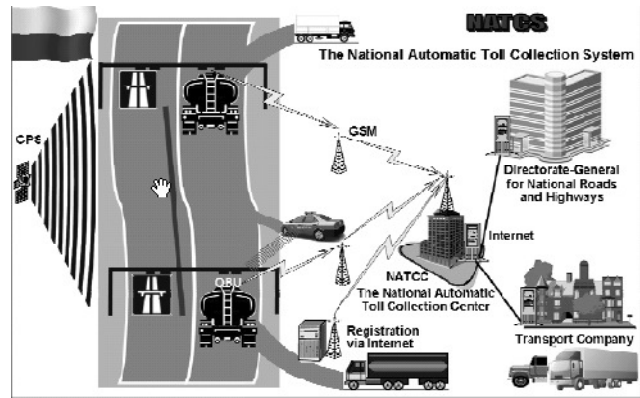

**A. Figures and Tables**

Toll Gate Exit Flow Chart

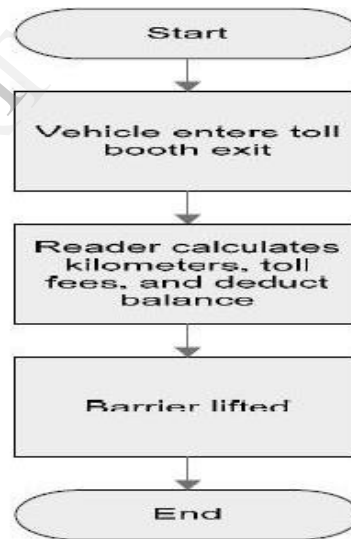

**IV. CONCLUSIONS**

The rapid spreading of ITS enables the researchers to find new methods or algorithms to use RFID technology in transport systems. The structure of the VLS based on RFID is designed depending upon that every vehicle is attached with RFID tags. When these vehicles travel along a road, all



information of vehicle's tag is read and transmitted real-time to CCS unit, to realize the purpose of real-time monitor of vehicles movement.

Therefore, after finishing the research work the following conclusions can be noted:

- During the design of the VLS, Rifi di Platform is used to simulate the connection RFID reader with the system and to testing the receiving, analysis and storage the data. The ability, functionality, efficiency, and further effects were tested by RTIS carefully, before introducing the system in a real-life.
- By the use RTIS, the system successfully synchronously connected with ten RFID readers, those readers are distributed on five intersections.
- VLS analyzed the received data from the distributed RFID readers in traffic intersections. Then, VLS concluded the vehicles locations and stored it in table. Vehicles locations table contained all the useful information about travels of the vehicles in road network.
- The location information of road intersection is preloaded by RFID readers. By tracing individual vehicles' information, VLS evaluated the road status throughout the city. VLS appraised the streets and traffic intersections congestion by depending on the average speed of vehicles in that location.
- The VLS monitored the intersections if a stolen or an illegal vehicle passed through them via checking blacklist in real-time. Also, it tracked vehicles that have a specific color in a traffic intersection during a certain period of time.

#### REFERENCES

- [1] Y. Guohao, T. Jun and C. Guochong, —RF Controller Development and Its Application in Intelligent Transport System||, Proc. of the IEEE International Workshop on Anti-counterfeiting, Security, Identification, ISBN: 1-4244-1035-5, pp. 113-116, Xiamen, Fujian, China, 2007
- [2] C. H. Li, "Automatic Vehicle Identification AVI System Based on RFID", Proc. of the IEEE International Conference on Anti-Counterfeiting Security and Identification in Communication (ASID), ISBN: 978-1-4244- 6731-0, pp. 281-284, Chengdu, China, 2010.
- [3] H. Lehpamer, ||RFID Design Principles||, Artech House Microwave Library, INC., ISBN 13: 978-1-59693-194-7, USA, 2008.
- [4] C. M. Roberts, "Radio Frequency Identification (RFID)", Computers & Security, Vol. 25, Issue 1, Feb.2006. Elsevier Ltd., DOI:10.1016/j.cose.2005.12.003, 2006
- [5] Nor Azlina , Bt Abd Rahman , Mohsen Bafandehkar, Behzad Nazarbakhsh , Nurul Haniza Bt Mohtar , "Ubiquitous Computing For Security Enhancement Of Vehicles", IEEE International Conference on Vehicular Electronics and Safety (ICVES) ,Beijing, pp: 113-118, 2011.