

Certain Investigation on Automatic Multitasking Shopping Trolley based on Rfid and Zigbee Technology

Tamilselvi. S
Ap/Ece
Nandha College of Technology,
Erode-52

Indhumathi. S, Kalaivani. R, Krishna. R
Ug Scholar/Ece
Nandha College Of Technology,
Erode-52

Abstract— Now a days purchasing and shopping at big Malls is becoming a daily activity in metro cities. We can see huge rush at malls on holidays and weekends the rush is even more when there are special offers and discount. If a consumer would like to buy something at a shopping mall, consumers need to take the particular items from the display shelf and then queue up and wait for their turn to make payment. The aim of our project is to implement the automatic goods carrier navigation and the billing system in the shopping malls. The structure of the goods carrier consists of the robotic structure and the color sensor, which is used to navigate the robotic goods carrier along the particular way. The keypad is used to give the commands to the controller for where the robotic carrier has to move on. The wireless billing system is made up of the ZigBee communication module.

Index terms : RFID reader, RFID tags, Wireless ZIGBEE Technology.

I. INTRODUCTION

RFID tags, or simply "tags", are small transponders that respond to queries from a reader by wirelessly transmitting a serial number or similar identifier. They are heavily used to track items in production environment and to label items in supermarkets. They are usually thought of as an advanced barcode. However, their possible area of use is much larger. This paper presents a few new applications that are possible using RFID technology such as locating lost items, tracking moving objects, and others.

RFID tags are expected to proliferate into the billions over the next few years and yet, they are simply treated the same way as barcode without considering the impact that this advanced technology has on privacy. This paper presents possible exploit RFID systems and some proposed solutions as well.

RFID is the special type wireless card which has an embedded chip along with loop antenna. The embedded chip represents the 12 digit card number. RFID reader is the circuit which generates 125KHZ magnetic signal. This magnetic signal is transmitted by the loop antenna connected along with this circuit which is used to read the RFID card number. In this project RFID card is used as security access card. So each product has the individual RFID card which represents the product name. RFID reader is interfaced with microcontroller. Here the microcontroller is the flash type reprogrammable microcontroller in which we already programmed with card number. The microcontroller is interfaced with keypad.

A. Related Work

While doing survey we found that most of the people prefer to leave the shopping mall instead of waiting in long queues to buy a few products. People find it difficult to locate the product they wanted to buy, after selecting product they need to stand along queue for billing and payment. To try to solve the problems previously identified recent years have seen the appearance of several technological solutions for hyper market assistance. All such solutions share the same objectives, save consumers time and money, help the retailers to win loyal clients. Satoru Ueharade fined the Web shopping cart system as a typical client-server application on the Web. Then they clarified several problems on the implementation of the Web shopping cart system, which are peculiar to the Web

In order to solve the problems, he proposed a new mechanism that can manage user sessions with high reliability and safety. He compared the Web shopping cart system implemented using the proposed mechanism with the one developed by the conventional methods. Chihhsiong Shih proposed an automatic embedded software generation framework that can create an embedded Zigbee applications.

The framework consists of two major modules, pattern extraction and code generation. Pattern extraction and development are designed to provide Zigbee application with model reuse and modification. System serves as a medium between pattern development and code generation. State diagram, class diagram and sequence diagram help describe a specific application scenario.

B. Nature of the Problem:-

When any selected product is dropped into the cart, RFID reader reads the tag against the product and the information of the product is extracted and displayed on the LCD screen. At the same time billing information is updated. The working of the Intelligent Shopping Cart can be explained with the following steps:

- 1) When shoppers with the cart press "start button" the system turns ON and then all the components such as RFID reader, microcontroller and physical media start working.
- 2) Every product has an RFID tag which contains a unique ID. These IDs are fed into the data base assigned to the corresponding products.

- 3) When the shopper drops any product in the cart then the RFID reader reads the tag. The information of the product is extracted and displayed on the LCD screen. At the same time billing information is also updated.
- 4) These steps are repeated until the end of shopping button is pressed. Once the "EndShopping" button is pressed the total bill is sent to master pc.
- 5) There is also an option provided to delete some of the products from the cart and the bill will be updated accordingly. This goes by the customer choice.
- 6) At the end of shopping, the customer can straight away pay the bill and leave.
- 7) Inventory status of the products is also updated at the end of shopping.

C. Previous work:-

Nowadays, if a consumer would like to buy something at a shopping mall, consumers need to take the particular items from the display shelf and then queue up and wait for their turn to make payment. Problem will surely arise when the size of a shopping mall is relatively huge and some times consumers don't even know where certain items are placed. Besides, consumers also need to queue for along time at the cashier to wait for turn to make payment. The time taken for consumers to wait for the customers in front of the queue to scan every single item and then followed by making payment will definitely take plenty of time. This condition will surely become worst during the season of big sales or if the shopping malls till uses the conventional way to key in the price of every item by hand to the cash register. On the other hand, consumer often have to worry about plenty of things when going to the shopping mall.

For example, most consumers will worry the amount of money brought is not enough to pay for all the things that wanted to be bought until it comes to our turn to pay at the cashier, consumers might also worry that whether certain food product available at the shopping mall or not, or suitable for vegetarians in most of the food product might not be stated clearly.

It will be a great convenience if the information of items that are available in the shopping mall can be obtained. It will be a great improvement on the existing system if the technology of RFID is implemented. Consumers will be able to get information of all the items at shopping mall, total up the prices of items as they shop, and save unnecessary time at the cashier.

II. LITERATURE SURVEY

Nowadays, if a consumer would like to buy something at a shopping mall, consumers need to take the particular items from the display shelf and then queue up and wait for their turn to make payment. Problem will surely arise when the size of a shopping mall is relatively huge and sometimes consumers don't even know where certain items are placed. Besides, consumers also need to queue for along time at the cashier to wait for turn to make payment. The time taken for consumers to wait for the customers in front of the queue to scan every single item

and then followed by making payment will definitely take plenty of time.

This condition will surely become worst during the season of big sales or if the shopping malls till uses the conventional way to key in the price of every item by hand to the cash register. On the other hand, consumers often have to worry about plenty of things when going to the shopping mall.

For example, most consumers will worry the amount of money brought is not enough to pay for all the things that wanted to be bought until it comes to our turn to pay at the cashier, consumers might also worry that whether certain food product available at the shopping mall are suitable for vegetarian since most of the food product might not be stated clearly.

It will be a great convenience if the information of items that are available in the shopping mall can be obtained. It will be a great improvement on the existing system if the technology of RFID is implemented. Consumers will be able to get information of all the items at shopping mall, total up the prices of items as they shop, and save unnecessary time at the cashier.

Block diagram

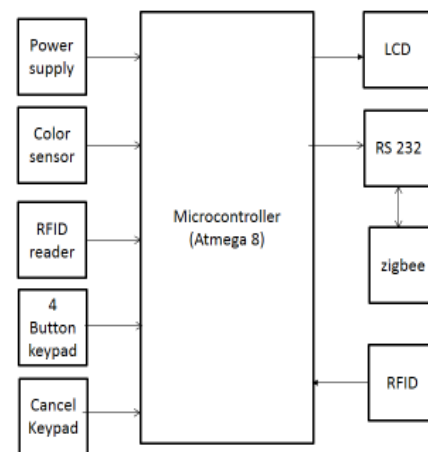

Fig.1 Navigation system block

III. COMPONENTS OF RFID

A basic RFID system consists of three components:-

1. An antenna or coil
2. A transceiver (with decoder)
3. A transponder (RF tag) electronically programmed with unique information.

These are described below:

A. Antenna:-

The antenna emits radio signals to activate the tag and read and write data to it. Antennas are the conduits between the tag and the transceiver, which controls the system's data acquisition and communication. Antennas are available in a variety of shapes and sizes; they can be built into a door frame to receive tag data from persons or things passing through the

door, or mounted on an interstate toll booth to monitor traffic passing by on a freeway. The electromagnetic field produced by an antenna can be constantly present when multiple tags are expected continually. If constant interrogation is not required, a sensor device can activate the field. Often the antenna is packaged with the transceiver and decoder. The reader emits radio waves in range of any where from one inch to 100 feet or more, depending upon its power output and the radio frequency used. When an RFID tag passes through the electromagnetic zone, it detects the reader's activation signal. The reader decodes the data encoded in the tag's integrated circuit (silicon chip) and the data is passed to the host computer for processing.

B. RFID transponders (tags):-

Consisting generally of Microchip Antenna Case Battery (for active tags only) the size of the chip depends mostly on the Antenna. Its size and form is dependent on the frequency the tag is using. The size of a tag also depends on its area of use. It can range from less than a millimeter for implants to the size of a book in container logistic. In addition to the microchip, some tags also have.

C. RFID tag:-

A radio-frequency identification system uses tags, or labels attached to the objects to be identified. Two-way radio transmitter-receivers called interrogators or readers send a signal to the tag and read its response.

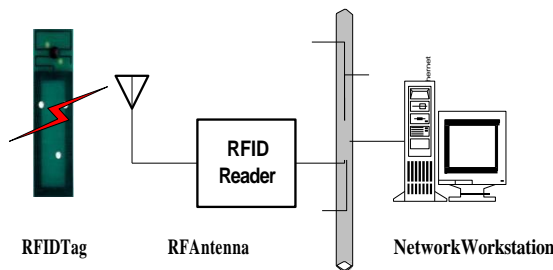

Fig.2 Working of an RFID Tag Antenna

RFID tags can be either passive, active or battery assisted passive. An active tag has a non-board battery and periodically transmits its ID signal. A battery assisted passive (BAP) has a small battery on board and is activated when in the presence of a RFID reader. A passive tag is cheaper and smaller because it has no battery.

Tags may either be read-only, having a factory-assigned serial number that is used as a key into a data base, or may be read/write, where object-specific data can be written into the tag by the system user. Field programmable tags may be write-once, read-multiple; "blank" tags may be written with an electronic product code by the user.

An RFID system is specifically designed to be asymmetric the reader is big, expensive and power hungry compared to the RFID tag. There are a number of different types of RFID system, but one basic categorization is based on the power source used by the tag. Passive tag RFID systems require no power source at the tag—there is no battery. Instead, the tag uses the energy of the radio wave to power its operation, much like a crystal radio. This results in the lowest tag cost, but at the expense of performance.

A. GLCD:-

This library makes it as to use a Graphical LCD with Arduino this is an extensive modification of the ks 0108 library that has higher performance, more features, supports more Arduino boards and is easier to integrate with different panels.

Sketches written for the old library should work with little or no modification. The configuration mechanism has been changed to facilitate use with a broad range of GLCD chip and ATmega Controllers, See the section on sketch migration for details on modifications for the new library.

B. Powersupply

Power supply is used to give the 5V to the controller. 5V can be received from IC voltage regulator. Inside the power supply rectifier, filter is present.

C. RFID tag reader

RFID reader is used to read the data's present in the RFID tag. RFID readers or receivers are composed of a radio frequency module, a control unit and an antenna to interrogate electronic tags via radio frequency (RF) communication. Many also include an interface that communicates with an application. Reader scan handheld or mounted in strategic locations so as to ensure they are able to read the tags as the tags pass through an "interrogation zone"

IV. HARDWARE AND SOFTWARE REQUIREMENT

A. Software interface

Language use: VB.net, Embedded 'C'
OS Compatible: XP, Vista, W7, W8

B. Hardware interface

System Configuration: 80GB HDD, 1GB RAM, 3.1GHz Processor

V. ALGORITHM

- STEP 1: Start
- STEP 2: Initialize System
- STEP 3: Search for RFID
- STEP 4: Check RFID tag
- STEP 5: Read related data from memory
- STEP 6: Display data on LCD
- STEP 7: Add items cost as items are added
- STEP 8: Bill calculation at trolley itself
- STEP 9: When uploaded key is pressed send data to the counter
- STEP 10: Print the bill
- STEP 11: Stop

VI. FLOW CHAT

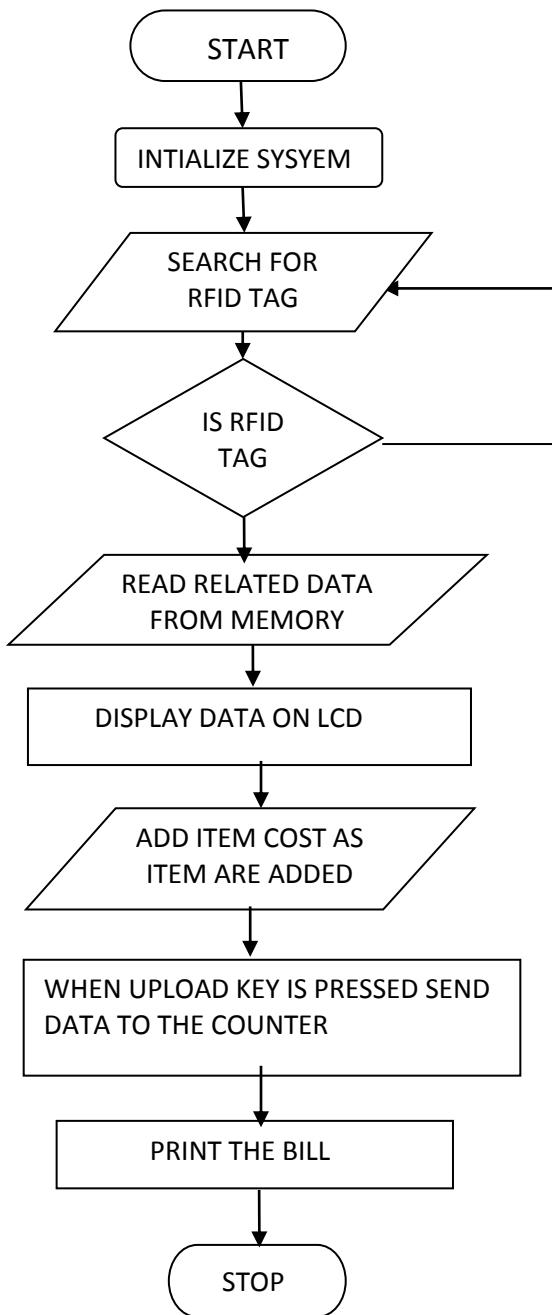

VII.PURPOSE OF THE PROJECT

The objective of this project is to improve the speed of purchase by using RFID.This project is designed to use the RFID based security system application in the shopping trolley.This project is used in shopping complex for purchase the products.

In this project RFID card is used as security access for product.If the product is put into the trolley means it will shows the amount and also the total amount.But in this project RFID card is used for accessing the products.So this project improves the security performance and also the speed.The trolley developed will also have the provision to take out the print out the bill of the purchase materials which will be designed using.net graphical user interface

with Access database.It will over come the Bar code technology which gets lot sof problems that will recover in this technology such as the bar code method is so slow and sometime it will creating error at the reading the barcode in case of damaged the barcode it wont be recognized the barcode tag by barcode reader.

A.Serial to USB converter:

It is used to connect the microcontroller output to the PC for Speech conversion.

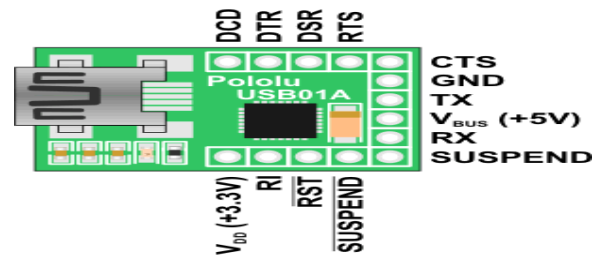

Fig.3 Serial to USB converter

USB to Serial processorchip ,this chip converts all the USB data to serial data and all the serial data to USB data,and a Serial driver chip,this chip provides the power for you're the device connected to the serial port of the adapter;it kind of amplifies the signals.

B. Contribution:

Project's foundation is aiming at providing multitasking system to help to improve performance it is most relevant for research,academic as well as institutions

C. Library management system:

The RFID is the recent technology used in library theft detection system.unlike Electro mechanically which have been used in libraries for decades,RFID based system move beyond security to be come tracking system that combine security with more efficient tracking of material through out the library including easier and faster charge and discharge inventorying and material handling.

RFIDisacominationofradiofrequencytechnologyandmicroc hip based technology.The information contained on the microchip in the tag affixed to library material is read using Radio Frequency technology regardless of it emorientationor alignment and the distance from the it emisnot a critical factor.The target used in RFID system can replace electromechanical theft detection targets and Barcodes.

D. Student attendance system:

This RFID student attendance system provide Robust Secure and Automatic Attendance system this system aims to automate the process of taking attendance on pen&paper and prevent fraudulententry.

It uses RFID tag to record attendance.Each student is assigned a unique tag which he/she required to swipe over the reader to give his/her attendance.This system benefits both the teacher and student as it quick and hassle free.This setup can be use din any educational institution regardless of which everboard they follow data is stored in a comma

separated value(CSV)file which keeps track of each day’s attendance.It should be cited as“to be published”Please give affiliations and addresses for private communications.Capitalize only the first word in a paper title,except for proper nouns and element symbols.For papers published in translation journals,please give the English citation first, followed by the original foreign-language citation.

E. Abbreviations and Acronyms

- [1] RFID :-Radio Frequency Identification
- [2] DoD :-Department of Defense
- [3] EAS :-Electronic Article Surveillance
- [4] EPC :-Electronic ProductCode
- [5] ISO :-IndianStandardof Organization
- [6] ARPT :-ActiveReaderPassiveTag
- [7] LCD :-LiquidCrystalDisplay
- [8] PCB :-PrintedCircuitBoard
- [9] BAP :-BatteryAssistedPassive
- [10] CRT :-cathode raytubes
- [11] PRAT :-PassiveReader ActiveTag
- [12] IDE :-Integrated DevelopmentEnvironment
- [13] SCC :-ServerCommunicationcomponent
- [14] UIDC :-UserInterface anddisplaycomponent
- [15] ABC :-Automatic billingcomponent

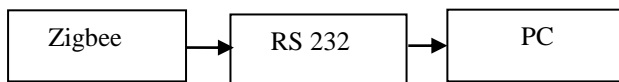

Fig.4billing system block

VIII.CONCLUSION

The intended objectives were successfully achieved in the prototype model developed.The developed product is easy to use,low-cost and does not need any special training.This project report reviews and exploits the existing developments and Different type so fradio frequency identification technologies which are used for product identification,billing,etc.We have also learned the architecture of the system that can be used in the shopping systems for intelligent and easy shopping in the malls to save time,energy and money of the consumers.Present trends point towards the fast growth of RFID in the next decade.With around 600 million RFID tags sold in the year 2005 alone,value of market including systems,services and hardware is likely to grow by factor of 10 between years 2006-2016.It is expected that total number of RFID tags delivered in the year 2016 will be around 450 times as compared to the ones delivered in the year 2006.

This project reviews and exploits the existing developments and Different type so fradio frequency identification technologies which are used for product identification,billing,etc.Thus the survey paper studies and evaluates research in sight in Radio Frequency Identification systems from a big picture first.We have studied in detail about the business model,technological model and all related work and applications in the domain of RFID based systems that make ease of identification.We have also learned the architecture of the system that can be used in the shopping systems for intelligentand easy shopping in the malls to save time,energy and money of the consumers.Thus RFID has a wide scope in the supply chain management.In the future,if all studies are favorable,we will advance with the implementation of a prototype for proposed architecture for testing in are alhypermarket scenario because RFID is a technology that has the potential to improve our lives to a very great extent. An RFID implementation that assumes for the time being large expenses will become approachable in the future.In many applications,the great cost of RFID technology will be balanced out by the achievement of the best solution and results.

REFERENCES

- [1] Control Theory& Informatics Issn 2224-5774(Print) Issn2225-0492(Online), Vol1, No1, 2011 Rfid Based Automatic Shopping Cart Saurabh Kumar Sultaina, Gourav Jaiswal, Prateek Jain
- [2] Internationalconference On Computing And Control Engineering (Iccce2012), 12&13 April, 2012 Smart Shopping Experience Based On Rfid.Vanitha
- [3] The Seventh International Conference On Sensor Technologies &Applications Smart Shopping Cart For Automated Billing Purpose Using Wireless Sensor Networks,Sanchita Roy,Udita Gangwal,Jyotsna Bapat.
- [4] Ieee Transcations On System, Man &Cyberneticspart C: Applications&Reviews, Vol.42, March 2012 Single Rfid Tag Ownership Transfer Protocols Gaurav Kapoor &Selyn Piramuthu.
- [5] Measurement, Vol.44, No.4, Pp.730-737, April 2011 Threshold-Based Identification Of Wireless Saw Rfid Tags With Pulse Position Encoding, G.Cerda-Villafana &Y.S.Shmaliy.
- [6] Parvathy A, Venkat Rohit Raj “ Rfid Based Examination Hall System”, A Paper On Ieee Paper.
- [7] J.Suryaprasad, B.O.P. Kumar, D. Roopa And A.K. Arjun, "A Novel Low-Cost Intelligent Shopping Cart", Ieee 2nd International Conference On Networked Embedded Systems For Enterprise Applications, Pp.1-4, 2011.
- [8] Kamran Ahasan,Paul Kingston Ieee Paper On “Rfid Applications:An Introductory And Exploratory Study”.