

# Automatic Star Delta Starter using Relays and Arduino for Induction Motor

Deepti Arela<sup>1</sup>, Ankit Vijayvargiya<sup>2</sup>,  
<sup>1,2</sup>Assistant Professor,  
Department of Electrical Engineering,  
SKIT, Jaipur

Himank Sharma<sup>3</sup>, Jagmohan Saini<sup>4</sup>,  
Jaiprakash Menariya<sup>5</sup>,  
Jitender Kumar<sup>6</sup>, Mahesh Kumar Yogi<sup>7</sup>  
<sup>3,4,5,6,7</sup>IV, B.Tech,  
Department of Electrical Engineering, SKIT, Jaipur

**Abstract:-** Star or Delta starters are the most common reduced voltage starters in the 50 Hz industrial motors. They are used in an attempt to reduce the starting current applied to the motor during start. The Star/Delta starter is generally manufactured using three contactors, a timer and a thermal overload for operating a 3-phase motor at 440 volt at AC mains supply of 50 Hz. However, in our project we have taken up the same to operate a 3-phase motor at 440 volt AC mains supply 50 Hz with a set of 12 volt DC relays an electronically adjustable timer provided through arduino and a set of miniature circuit breakers. The interlocking arrangement of the relay coils and the electronic arduino is all wired in low-voltage DC of 12 Volt fed from an in-built DC power supply for safe handling of the starter during the study, still retaining its application for a 3-phase motor starting with a single phasing prevention.

The timer comprises of Arduino the output of which is fed to a relay for changing the mains supply from 3-phase star to delta. The project also has the provision of single phase protection, since the 3-phase motors may get burnt if any one phase goes missing during operation. The output to the lamps shall be completely cut off in the event of any phase failure. Furthermore, the project can be enhanced by using thyristors in a firing angle control principle for soft start of the induction motor that would overcome all the drawbacks of the star delta starter.

## 1. INTRODUCTION

Due to the wide variety characteristics of the induction motor, it plays the premier role in the industrial sector. Some of those are self starting, rugged construction, high efficiency, good power factor and ease of control, etc. Squirrel cage type of induction motors are mostly used widely than the other types.

When the motor is at idle, it just look like short circuited transformer at secondary side because all the rotor bars are connected together to form a closed path. This will turn a large current flow through the rotor bars. So when the motor is started, stator draws the high current which is 8-10 times that of the motor rated current. Before starting the motor, it is necessary reduce the voltage applied to the motor.

The project is designed to provide low voltage start to induction motors. This is achieved by using star to delta conversion. Star/Delta starters are probably the most common reduced voltage starters in the 50Hz industrial motor world. Star delta is used in an attempt to reduce the

start current applied to the motor then after sometime full load current is applied to the motor. Since in star connection current is same in different phases while line voltage is the root three times the phase voltage. So the voltage is reduced (results to reduce current) if motor is started as star. And also in delta connection the voltage is same as that of phase voltage so full voltage is applied if we run the motor as delta connection. The Star/Delta starter is generally obtained from three contactors; arduino and a thermal overload for operating a 3 phase motor at 440 volt at ac mains supply 50 Hz. The interlocking arrangement of all the contactor coils is traditionally wired in 440 volt AC. The project is designed to start a 3 phase motor at 440 volt AC mains supply 50 Hz with a set of 12 volt DC relays in star mode and then to delta mode by an electronically adjustable timer. A set of relays are used to shift the motor connections from star to delta with a time delay. The project is supplied with six lamps in a 3 phase motor i.e., 3 lamps will work when motor is in star connection and when it will get converted to star to delta all 6 lamps will operate.

## 2. TECHNOLOGY

The Arduino UNO is an open-source microcontroller board based on the Microchip ATmega328P microcontroller and developed by Arduino.cc. The board is equipped with sets of digital and analog input/output (I/O) pins that may be interfaced to various expansion boards (shields) and other circuits. The board has 14 Digital pins, 6 Analog pins, and programmable with the Arduino IDE (Integrated Development Environment) via a type B USB cable. It can be powered by a USB cable or by an external 9 volt battery, though it accepts voltages between 7 and 20 volts. "Uno" means one in Italian and was chosen to mark the release of Arduino Software (IDE) 1.0. The Uno board and version 1.0 of Arduino Software (IDE) were the reference versions of Arduino, now evolved to newer releases. The Uno board is the first in a series of USB Arduino boards, and the reference model for the Arduino platform. The ATmega328 on the Arduino Uno comes pre-programmed with a boot loader that allows uploading new code to it without the use of an external hardware programmer. It communicates using the original STK500 protocol.

An arduino is used as a timer in this project “automatic star delta starter using relay for three phase induction motor”, where pin number 2 is used for start and pin number 3 for stop. Pin number 8 is used for star and 9 for delta connection. The pin number 2 starts the timer with starting of motor in star connection and after 30 seconds the motor changes to delta connection which is stopped by pin number 3.

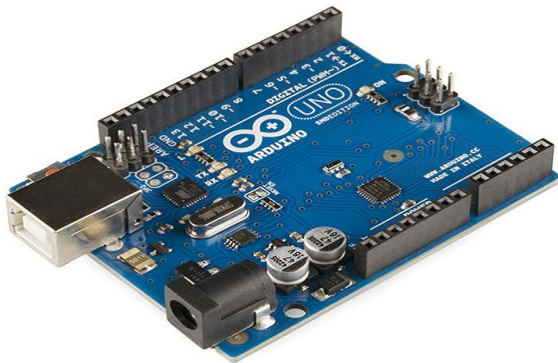

Figure - Arduino

### 3. CIRCUIT DIAGRAM

In given above circuit diagram firstly Three phase supply 415V AC is given to the three single phase transformer 230/12 Volts output from one of these transformers is supplied to the Printed Circuit Board through three sets of bridge rectifiers to operate the 12 Volt DC relays. It is also used to run the microcontroller through the 7809 Voltage regulator which gives an output of 9 volt DC output which is given to the arduino supply from other two transformers are used to operate the star and delta connected relays which operate with a time delay of 3 second set by the microcontroller. This changes the operation of motor from star mode in the starting to delta mode after the fixed time delay. It operates the motor windings from the high inrush current during starting of the motor and allows only  $1/\sqrt{3}$  of the rated current. After the fixed time delay the motor is switched to delta mode of operation allowing full load current.

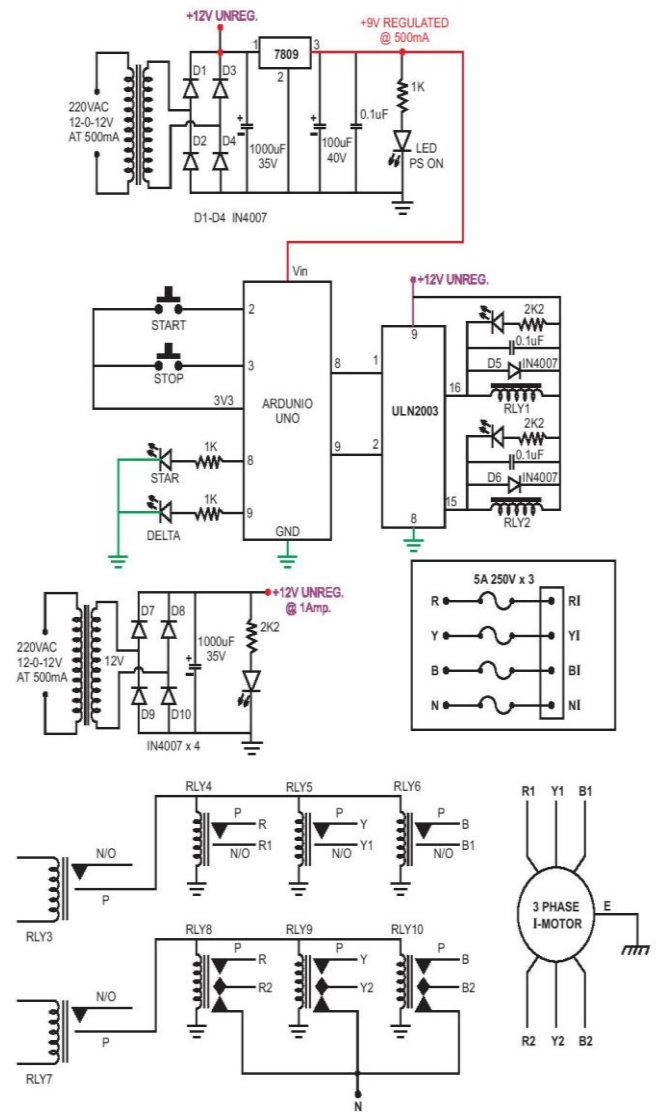

Figure-Circuit diagram of Automatic star- delta starter

### 4. FUTURE SCOPE

For star delta starter, the basic function is to enable the motor to start and the motor windings are configured in a star formation to the supply voltage. The voltage applied for star delta starter to the individual motor winding is therefore reduced by a factor of  $1/\sqrt{3} = 0.58$  this connection amounts to approximately 30% of the delta values.

- Compared to the reduced voltage methods it is the simple and cheapest way of starting the motor
- An automatic voltage fluctuation protector system has been implemented for protection of induction motor
- It can there be easily commercialized

### 5. CONCLUSION

In this project we have developed automatic star delta starter for induction motor with the help of Arduino. This system provides solution for increased starting current we

can conclude that this type of starting is used for low to medium voltage applications. It is the cheapest way to reduce the starting current for three phase induction motors as it is in the order of three to four times that in case of direct online starter. By this project we can conclude that this method of starting the motor can be easily implemented with the help of relays and the Arduino circuit. The way of connecting the relays gives prevention of the motor from the single phasing. It has been implemented by the using of induction motor starter but here in our project we are using six lamps with induction motor. Star- delta starter are also used by Direct on Line method but by automatic star delta starter they will be switched from one mode to other automatically by the use of adjustable Arduino code. Initially code will set a finite no. of second to switch over from star to delta operation mode. Basically the main advantages of this method is to protect the motor of high starting current but in DOL method motor will not be protected well. The display of the monitored voltage is easily indicated by the difference in the glowing of number of lamps.

## 6. REFERENCE

- [1] K. Sundareswaran and B.M. Jos, 2005. Development and Analysis of Novel Soft-Starter/Energy-Saver Topology for Delta-Connected Induction Motors, IEE Proc.- Electr. Power Appl., 152(4).
- [2] Kato, Masakazu, Orikawa, Koji, Itoh, Jun-ichi, Saitoh, Noboru, 2013. Fast Starting Method Using Both Inverter And Delta-Star Starter For Weaving Machine Drive Systems, IEEE 1st International Future Energy Electronics Conference (IFEEEC) - Tainan, Taiwan.
- [3] Henk de Swardt, Star Delta starting and dual Voltage motors explained, 2007. Marthinusen & Coutts (Pty.) Ltd. A division of Savcio Holdings (Pty.) Ltd. Rev.
- [4] IEEE standard test procedure for polyphase induction motor and generators, IEEE standard 112-1996, New York, May 1997.
- [5] J. Nagrath, D. P. Kothari, "Electrical Machines", 2nd ed., Tata McGraw Hill, New Delhi
- [6] G. C. Soukup "Cause and analysis of stator and rotor failures in three phase squirrel cage induction motors", IEEE Trans. Ind. Applicat, vol.28, no.4, pp.921-937 1992
- [7] AkshayRohilla,Harish Chand Joshi, AnuragNegi,"Star Delta Starter of Induction Motor",2014IJIRT,Volume 1Issue 6,ISSN:2349-6002.
- [8] AssfaqHussain,"Electrical Machines",SecondEdition,PublicationDhanpatrai and Co-operative.
- [9] Sunil.S.Rao,"Switchgear Protection and power system", Khanna Publication