

# Automatic LPG Booking, Leakage Detection And Real Time Gas Measurement Monitoring System

B. D. Jolhe, P. A. Potdukhe, N. S. Gawai

*Jawaharlal Darda Institute of Engineering and Technology*

## Abstract

*A cost-effective, automatic Liquefied Petroleum Gas (LPG) booking, leakage detection and real time gas monitoring system is proposed in this paper. In this system, the LPG leakage is detected through the sensor and information is sent to the user by Short Message Service (SMS) and simultaneously alerts the customer using a GSM module, while activating the alarm and exhaust fan. The additional advantage of the system is that it continuously monitors the level of the LPG present in the cylinder using weight sensor and automatically books the cylinder using a GSM module.*

## 1. Introduction

LPG, first produced in 1910 by Dr. Walter Snelling is a mixture of Commercial Propane and Commercial Butane having saturated as well as unsaturated hydrocarbons. Because of the versatile nature of LPG it is used for many needs such as domestic fuel, industrial fuel, automobile fuel, heating, illumination etc and the demand for LPG is on an exponential raise day by day. The leaked gases when ignited may lead to explosion. The number of deaths due to the explosion of gas cylinders has been increasing in recent years. Thus there is a need for a system to detect and also prevent leakage of LPG.

Before the development of electronic household gas detectors in the 1980s and 90s, gas presence was detected with a chemically infused paper that changed its colour when exposed to the gas. Since then, many technologies and devices have been developed to detect, monitor, and alert the leakage of a wide array of gases. Today, booking an LPG cylinder is now just a text message away. Petroleum companies have launched the customer-friendly service called as IVRS (Interactive voice Response) technique for their customers.

Hence the requirement of an efficient system to measure and display the level of LPG is inevitable, which may be used for domestic purposes. Here we intend to propose a microcontroller based system where a gas sensor, MQ6 is used to detect dangerous gas leaks. This unit is incorporated into an alarm unit, to sound an alarm or give a visual indication of the LPG leakage. The sensor has good sensitivity combined with a quick response time at low cost. If leakage is detected, message to the authorized person or family member using cellular network called GSM is sent automatically. It also provides a feature to measure weight of LPG cylinder with its value on LCD display. A gas quantity of less or equal to 10kg books the cylinder automatically by sending text message to a dealer. Also when cylinder weighs less than or equal to 0.5 Kg, it informs the family members by sending a message to refill the cylinder.

## 2. System Overview

The system block diagram comprises of parts as shown in figure 1. It consists of microcontroller (ATMega16A), gas sensor, weight sensor (Load Cell-L6D), GSM module (SIMCOM 300), and display(s).

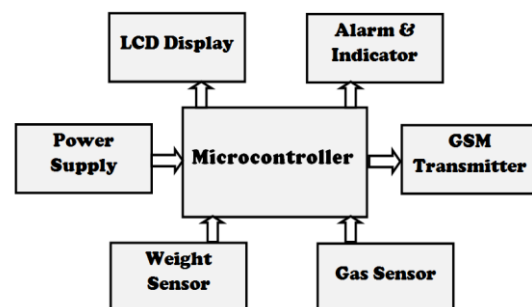

Figure 1. System block diagram

### 2.1 Microcontroller

An efficient and fast working controller is needed to continuously sense the LPG gas and its level (weight) sensor's output. Also a fast reply is desired when leakage is found. Along with this a system must

possess capacity to store some information which can be used for further processing.

Above operations require a very fast, single cycle execution rate microcontroller like ATmega16A. As shown in above figure 1, the microcontroller is at the centre of the system. It is having features like 16Kb internal RAM making easy storage of entire code in microcontroller itself, also the 1 MIPS per MHz instruction cycle execution rate enhanced overall system performance.

The LCD module connected to port B of ATmega16A in 4-bit mode is used to display the required messages. GSM module using AT commands connected to Rx and Tx pins of port D of ATmega16A are used to receive and transmit messages to desired family members and distributor. The weight sensor module output taken from relay circuit is connected to pins of port A which is used to monitor gas level continuously.

## 2.2 Gas sensor

The LPG gas consists of isobutene, propane, methane, etc. A sensitive, efficient gas sensor is required that senses only LPG gas contents and is less sensitive to other gases like cooking fumes, cigarettes, etc.

Sensitive material of MQ-6 gas sensor is SnO<sub>2</sub>, which has lower conductivity in clean air and its sensitivity increases with the concentration of gas, also it avoids gases like cooking fumes. It requires a voltage of 0-5 volts which is low and safe as per as the gaseous environment is considered.

This sensor continuously senses the gas, and if concentration level goes above danger level then it turns relay ON which gives interrupt to microcontroller and alternately switches on buzzer and exhaust fan.

## 2.3 Weight Sensor Module

To book a cylinder from a distributor, we must be aware in advance of amount of gas in the cylinder, and for this purpose the level of gas present in the cylinder has to be monitored continuously.

The load cell having required weighing capacity for domestic cylinder is used and for calibration purpose the weight sensor module is used along with the load cell. L6D weight sensor module is implemented in the system. The load cell output drives a relay circuit which gives two logic pulses (for  $\leq 10$  kg and  $\leq 0.5$  kg) as per truth table (figure. 4), which are further connected to microcontroller port pins to detect the gas level.

## 2.4 GSM Module

Gas sensor detects the presence of gas, weight sensor gives the gas level in cylinder, and microcontroller will take corrective or necessary actions. The status of all these happening has to be conveyed to the owner of system or housemates.

The technology making it very easy to send and receive messages using GSM module works on simple AT commands which can be implemented by interfacing it to the microcontroller Rx and Tx pins. The GSM module used is SIMCOM 300 which uses SIM memory to store the number of system owner or housemates and distributor or to whoever the messages have to be forwarded. It requires very less memory to send and receive text messages and operates on simple 12 Volt adapter.

## 2.5 Displays

As the system performs controlling and monitoring operations, it is primary requirement to put a display in the system which shows various message such as gas leakage detection, booking number of cylinder in case of refill of cylinder and also will display actions taken by microcontroller.

Liquid Crystal Display (LCD) of 16X2 characters operating on +5Volt supply and operated in 4-bit mode is implemented for the task of displaying required messages. Interfacing with ATmega16A and short code of programming makes it very useful to make system more user friendly.

## 3. System Operation

There are two flow charts for gas leakage detection and automatic gas booking which explain the methodology of the operation as follows:

### 3.1 Gas Leakage Detection

In this prototype, gas leakage detection has been given a highest priority. MQ6 placed in the vicinity of the gas cylinder. In the advent of leakage, the resistance of the sensor decreases increasing its conductivity. Corresponding pulse is fed to microcontroller and simultaneously switches on the buzzer and exhaust fan which we can reset by a manual reset switch.

Also a logic high pulse (+5 V) is given as an interrupt to INT0 pin of ATmega16 Microcontroller. Microcontroller sends a message "EMERGENCY ALERT: LPG gas leakage found in your home" to required cell numbers via GSM module and the same will be displayed on LCD.

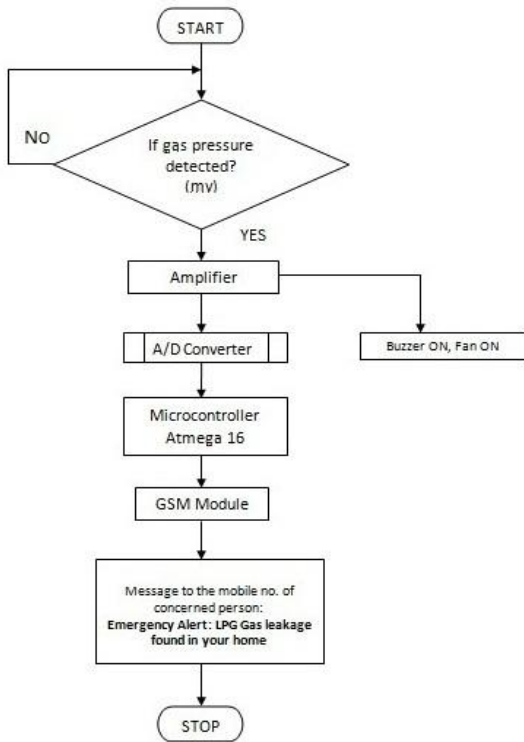

Figure 2: Gas Leakage Detection

3.2 Automatic Gas Booking

In automatic Gas booking system, L6D continuously monitors the weight of the gas in cylinder and displays it on seven segment display. When the weight of the gas is  $\leq 10$  Kg, a logic high pulse is fed to a port pin of microcontroller. As this pin goes high, microcontroller will send a booking message to distributor of format, "REG\_AMARGAS\_12345". At the same time, the message will be displayed on LCD as "Booking Cylinder".

When the weight of the gas goes below 0.5 kg another logic high pulse is fed to another port of microcontroller through a relay circuit as discussed in truth table. As this port pin goes high, microcontroller will send a message as "Gas remaining only 0.5 Kg. Immediately Refill your Cylinder" through a GSM module to cell numbers required members and the message "Cylinder Empty, Please Refill" is displayed on the LCD display.

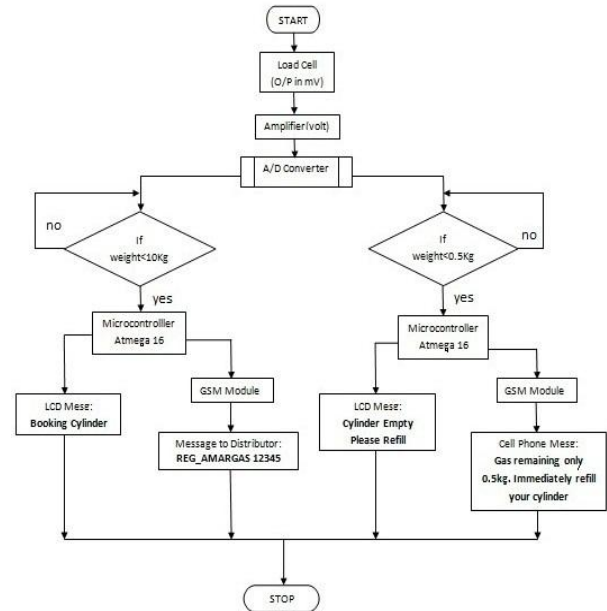

Figure 3: Automatic Gas Booking

4. Experimental Setup

ATMega 16 is the base of the system. The inputs given to the ATMega 16 are the output of gas sensor MQ-6 and load cell L6D. The output of ATMega 16 are given to the SIMCOM 300 and LCD 16x2 display.

The gas output of MQ6 is given to the INTO pin of ATMega 16 as far as the highest priority is given to the leakage detection. The output of L6D is amplified and digitized by A/D converter and is given to the port pins PA0 and PA1 of ATMega 16 as per the truth table in figure 4.

PA0	PA1	Conditions
0	0	Full Cylinder
1	0	Booking Cylinder( $\leq 10$ Kg)
1	1	Empty Cylinder( $\leq 0.5$ Kg)

Figure 4: Truth table

The Rx and Tx pins of GSM are connected to the Tx and Rx pins of ATMega 16 respectively. The output is shown by the LCD display which is operated in 4 bit mode. The higher data pins D4-D7 are connected to the PB0-PB3 pins and control pins R/s, R/W and Enable pins of LCD are connected to ATMega 16.

The output of the MQ6 drives the relay circuitry which eventually switches on the alarm and exhaust fan

as soon as the gas is detected and both are reset by a manual reset switch.



## 5. Result

The system prototype is constructed and when a small amount of LPG is brought near the system, the system sensor detects the leakage and sends the SMS to housemates and activates the alarm and switches on the exhaust fan. Also system prototype continuously monitors the LPG level of the cylinder and books the cylinder automatically.

## 6. Conclusion

A cost-effective gas leakage detection system was proposed, designed and successfully implemented in this paper. Along with gas leakage detection, this system gives a fully automated approach towards the gas booking. Real time weight measurement of the gas and its display on LCD makes it an efficient home security system and also can be used in industries and other places to detect gas leaks. The cost involved in developing the system is significantly low and is much less than the cost of gas detectors commercially available in the market.

## 7. References

- [1] Sunithaa.J, Sushmitha.D, "Embedded control system for LPG leakage detection and prevention" *International Conference on Computing and Control Engineering (ICCCE 2012)*, 12 & 13 April, 2012
- [2] V.Ramya, B. Palaniappan, "Embedded system for hazardous gas detection and alerting" *International Journal of Distributed and Parallel Systems (IJDPSS) Vol.3, No.3, May 2012*
- [3] Mr. Sagar Shinde, Mr.S.B.Patil, Dr.A.J.Patil, "Development of movable gas tanker leakage detection using wireless sensor network based on embedded system", *International Journal of Engineering Research and Applications (IJERA) ISSN: 2248-9622 www.ijera.com Vol. 2, Issue 6, November- December 2012, pp.1180-1183*
- [4] M. B. Fish, R.T. Wainer, "Standoff Gas Leakage detectors based on tunable diodes laser absorption spectroscopy"
- [5] A. Mahalingam, R. T. Naayagi, N. E. Mastorakis, "Design and Implementation of an Economic Gas Leakage Detector", *Recent Researches in Applications of Electrical and Computer Engineering*
- [6] S. Rajitha, T. Swapna, "Security alert system using GSM for gas leakage" *International Journal of VLSI and Embedded Systems-IJVES*
- [7] Taufiq Noor Machmuda, "LPG Gas Detector and leak prevention based microcontroller"
- [8] A. CheSoh, M.Sc.; M.K. Hassan, M.Eng.; and A.J. Ishak, M.Sc. "Vehicle gas leakage detector"
- [9] National Institute of Health. (2004). "What you need to know about natural gas detectors". <http://www.nidcd.nih.gov/health/smelltaste/gas>
- [10] Fraiwan, L.; Lweesy, K.; Bani-Salma, A.Mani, N, "A wireless home safety gas leakage detection system", *Proc. of 1st Middle East, Conference on Biomedical Engineering*, pp.11-14, 2011.
- [11] Nasaruddin, N.M.B.; Elamvazuthi, I.; Hanif, N.H.H.B.M, "Overcoming gas detector fault alarm due to moisture", *Proc. of IEEE Student Conference on Research and Development*, pp. 426-429, 2009.
- [12] Nakano, S.; Goto, Y.; Yokosawa, K.; Tsukada, K, "Hydrogen gas detection system prototype with wireless sensor networks", *Proc. of IEEE Conference on Sensors*, pp. 1-4, 2005.
- [13] Hanwei Electronics Co. Ltd (2002), *MQ-6 Gas Sensor Technical Data*.
- [14] ATmega 16 Datasheet; [www.atmel.com](http://www.atmel.com)
- [15] Kelvin R. Sullivan, "Understanding Relays", *A tutorial on relays*.
- [16] SIMCOM Ltd, 27<sup>th</sup> Dec, 2005, "SIM 300 Hardware Specification Manual"
- [17] Display Elektronik GmbH Datasheet; LCD Module, DEM 16216 SYH-PY
- [18] Technical Data MQ6 Gas Sensors, [www.hwsensors.com](http://www.hwsensors.com)
- [19] Aluminum Single-Point Load Cell Datasheet, model 1004, [www.vpgtransducers.co](http://www.vpgtransducers.co)