

Automatic Car Jack and Pressure Monitoring System

Prof. Deepti Patne
(Guide)

Dept. of Instrumentation Engineering
Vidyavardhini's College of Engineering &
Technology
Mumbai, India

Tarun S. Nair
(Author)

Dept. of Instrumentation Engineering
Vidyavardhini's College of Engineering &
Technology
Mumbai, India

Gauri M. Kadam
(Author)

Dept. of Instrumentation Engineering
Vidyavardhini's College of Engineering &
Technology
Mumbai, India

Anushka A. Mahadeshwar
(Author)

Dept. of Instrumentation Engineering
Vidyavardhini's College of Engineering &
Technology
Mumbai, India

Pradnyesh Redkar
(Author)

Dept. of Instrumentation Engineering
Vidyavardhini's College of Engineering &
Technology
Mumbai, India

Abstract— Our main objective is to make a motorized jack that will save time, be faster and easier to operate, requires less human energy and additional work to operate and also safe, reliable and able to raise and lower the level. Most of the people are familiar with the basic car jack (manually operated) that is still included as standard equipment with most new cars. Operating the manual car jack is quite difficult job for mainly women's and old men cannot be used on the uneven surface. The purpose of this project is to encounter these problems. The automatic car jack basically works on the conservation of the motion that converts the rotary motion into the translatory motion. The automatic car jack is operated by turning the leadscrew with the motor which is controlled by using the mobile. The motor is driven by the 12V battery which is generally the battery of car itself. Tire pressure monitoring system will ensure that all tires are inflated properly and the system uses a sensor that is mounted in the wheel to measure air pressure in each tire. This will result into increasing the lifetime of tire and reducing fuel consumption.

Keywords— Scissor Jack, Wiper Motor, Tire Pressure Monitoring System.

I. INTRODUCTION

A car jack is a mechanical device used to easily lift heavy load cars, to gain an easy access to sections underneath vehicles or to simply just change a wheel. The most important fact of a jack is that it gives the user a mechanical advantage by changing rotational force into linear, allowing the user to lift heavy structures up that would be impossible to do without this tool. Normal car jacks are mechanical and that is rated for maximum lifting capacity of 1.5 tons or 3 tons. There are different types of car jack structures, some consist in having a screw threaded component that allows the changes in height, others are more "automatic" as they use a hydraulic or pneumatic system that pump fluid and pressured air to make components rise and force the structure to operate; some

structures require more mechanical force than others. The mechanical advantage is the factor by which a mechanism multiplies the forces or torque applied to it.



Fig.1.1 Different Jacks

II. OBJECTIVE

1. To design a car jack that is safe, reliable and able to raise and lower the height level.
2. To develop a car jack that is powered by dc power and fully automated with an android system.
3. Pressure Monitoring System installed in the tire to indicate whether the pressure in the tire is less than the desired set point and its output to be displayed on the app or the LCD screen inside the car.

III. EXISTING SYSTEMS

Based on past paper presentation and the research of IEEE papers on our topic of Automatic car jack we have handpicked some of the relevant topics that best described the working progress and the current scenarios. Based on those research paper we have concluded and have put forward our project to work and help the technology grow further for the betterment and easiness of the working environment.

A. Automatic Hydraulic Car Jack

Explains about the integrated automated jack for 4 wheelers, i.e. by the single push button provided an automobile jack can be operated. The system consists of three main parts that is hydraulic pump, driven by an electric motor, hydraulic cylinder for vehicle lift. During the breakdown condition hydraulic jacks actuate separately for either side of car. By the oil incompressible of the hydraulic jack the lifting capacity is more compared with the pneumatic system where it operates on air which is compressible. With the single acting cylinders which are controlled by the control valves and the relief valve the circuit has been done.

B. Inbuilt Automatic Hydraulic Car Jack

This paper describes explains about 'Inbuilt jack in Automobile vehicles. On front and rear part of the chassis of the automobile, hydraulic jack system is attached. It can be easily attached to all kinds of automobile chassis and frames. There is a front and rear suspension hydraulic jack that is centrally mounted to front and rear suspension of automobiles between wheels respectively. It is operated by 12v dc current and works on the principle of hydraulic power. It becomes easy for the maintenance of automobiles especially heavy vehicles by implementing this system. Pascal's principle is involved in the working of the hydraulic jack system. It states that at all points in the closed container or the cylinder pressures remain same at all the points. If there are two cylinders connected small and large. Force exerted by the large cylinder is more as the area is more, provided that pressure applied remains constant. It is represented by the equation $P=F/A$ to $F=PA$. Oil pressure is used by hydraulic jack to displace vehicles up and down by moving the handler. Hydraulic fluids act as a motive medium in hydraulic machinery. Hydraulic cylinders are powered by hydraulic fluids. In this system energy supplied is not absorbed by the Hydraulic fluid.

C. Automatic Car Jack Using Internal Car Power

This paper gives information on development of auto car jack using internal car power. By the manual force car jack is a mechanical advantage to allow a human to lift a vehicle. The internal cigarette lighter power (12volts) in order to ensure the power is adequate, gear was used. In this paper they have used two relays where it is connected to the motor with the 12V power supply has been used for switch circuit. And implementation the prototype for the modification on the features and design, it was implemented on PERODOA Kancil, with the higher torque such as Proton Wira and Proton Iswara car.

D. Equations

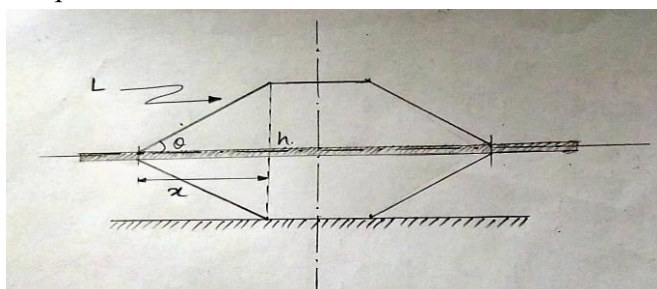

Fig.1.2

- In one revolution Linear displacement = Pitch of screw

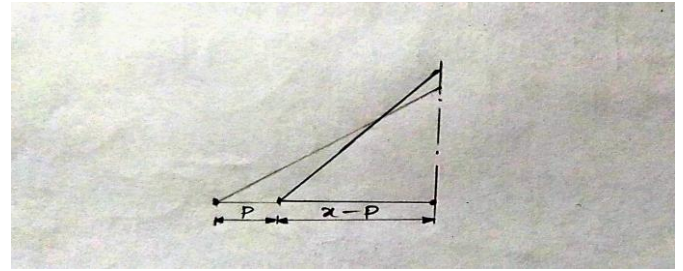

Fig.1.3

- $\cos(\Theta) = (L / x)^{-1}$
- P is known with outer of the motor
- $\cos \Theta = (L / (x - P))^{-1}$
- $L = (x - P) (\cos \Theta)^{-1}$
- $h = L \sin(\Theta_0)$
- $h_0 = [(x - nP) / \cos(\Theta_0)] * \sin(\Theta_0)$

$$h_0 = (x - nP) \tan(\Theta_0)$$

- where, n is the number of revolutions.

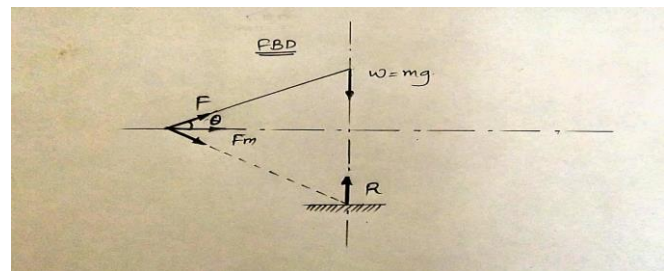

Fig.1.4

- $F_m = 2 F \cos(\Theta)$
- F is lifting of the body.
- $2 F \sin(\Theta_0) > mg$
- As Θ_0 increases with the revolutions, so does $F \sin(\Theta_0)$
- Maximum Force would be required at the beginning is, $\Theta = \Theta_0$
- Assuming, $\Theta_0 = 20^\circ$
- $2 F \sin(20^\circ) > 500$
- $F > 500 / 2 \sin(20^\circ)$
- $F = 730.95 \text{ N}$
- Considering, $F = 750 \text{ N}$
- $\tau = F * r = 750 * 0.1 = 75 \text{ Nm}$
- $P = \tau * w$
- Taking $n = 60 \text{ rpm}$
- $P = 75 * 2 \pi$
- $P = 471.23 \text{ watts}$

$$P \geq 0.631 \text{ hp}$$

IV. PROPOSED SYSTEMS

Designed a car jack such as it is permanently fitted to the car chassis by welding it and with the help of wiper motor the jack will be lifted up.

The motor works on the command from the app on the mobile phone. Redesigned the chassis model of the car such that the jack will be aligned with the chassis itself. This will prevent the jack from bumping into any obstacle on the road.

Using a pressure sensor, the tire pressure is monitored and the signal from the sensor is sent to the GSM module with the help of radio frequency. Finally, a message is sent on the user's phone indicating the tire pressure only if it is less than the set point / desired value.

A. Block Diagram

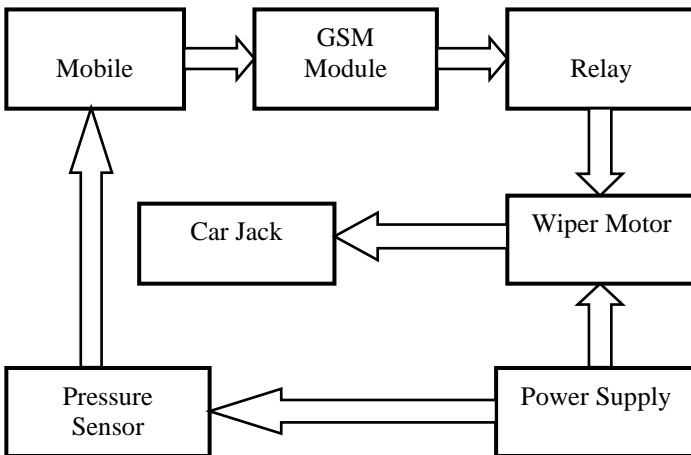

Block Functions -

- GSM module:** - A GSM Module is basically a GSM Modem (like SIM 900) connected to a PCB with different types of output taken from the board – say TTL Output (for Arduino, 8051 and other microcontrollers) and RS232 Output to interface directly with a PC (personal computer).
- Wiper Motor:** -Wiper motors are devices in the wiper system that functions on a power supply in order to move the wiper blades in a smooth motion. The wiper motor rotates continuously in one direction which is converted into a back and forth motion. The different power sources are the car batteries, voltages (12volts DC), current (minimum of 1.6 amps at 70 rpm; 1 amp at 41 rpm), computer batteries (12volts output) and other battery supplies that does not exceed the limit of 12 volts otherwise the motor is bound to overheat.
- Arduino Uno:** -Arduino Uno is a microcontroller board based on the ATmega328P. It has 14 digital input/output pins (of which 6 can be used as PWM outputs), 6 analog inputs, a 16 MHz ceramic resonator (CSTCE16M0V53-R0), a USB connection, a power jack, an ICSP header and a reset button.

B. Design & Implementation

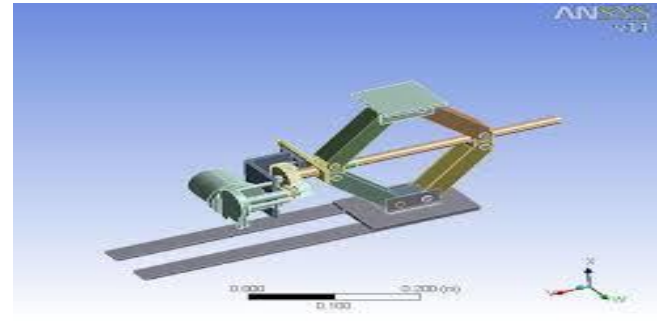

Fig 1.5 Motor Attached to the Jack

An electric motor is an electrical machine that converts electrical energy into mechanical energy. Most electric motors operate through the interaction between the motor's magnetic field and electric current in a wire winding to generate force in the form of rotation of a shaft. A gear is a rotating machine part having cut teeth which mesh with another toothed part in order to transmit torque. By introduction of an electric motor in the power screw, connecting gear with the pinion, the electric switch connected to the motor and plugged to the 12V battery source to generate power for the motor. The power screw is rotated through its gear when electrical power flows through it. the lifting and uplifting are done by changing the battery supply to the motor.

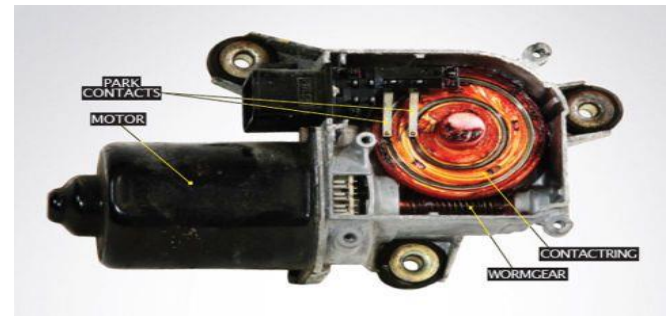

Fig1.6 Wiper Motor

With the above stated attachment to the jack the jack becomes automatic in operation. When the motor is connected to battery of car, current flows through motor. A switch is provided for changing the polarity of motor. Hence as the motor rotates the pinion connected to it rotates. The pinion is in mesh with the gear on the lead screw. Because of the gear ratio provided the torque gets multiplied and required torque is applied at the screw. As the screw of jack rotates the jack moves up. The whole assembly is required to be moved in horizontal as well as vertical direction simultaneously.

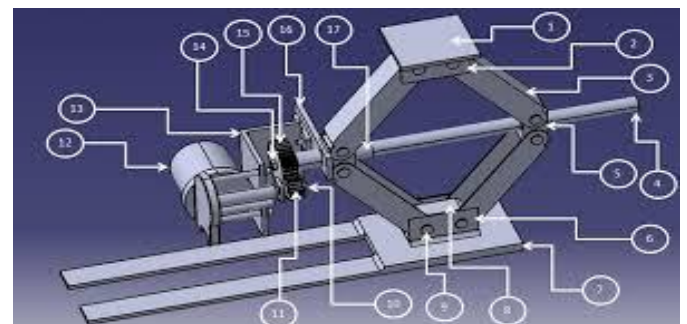

Fig.1.6 Motorized Jack

Now when the jack is lifted sufficiently to remove the tire the switch is made off. The tire then can be easily removed. After repairing the tire, it is fixed to car. Now with the help of switch the current supply can be reversed so that the jack can be lowered. In this way the jack can be operated easily without much fatigue.



Fig 1.7 Jack Lifting Vehicle

A tire-pressure monitoring system (TPMS) is an electronic system designed to monitor the air pressure inside the pneumatic tires. Direct tire pressure monitoring system uses a sensor mounted in the wheel to measure air pressure in each tire. When air pressure drops 25% below the manufacturer's recommended level, the sensor transmits that information to your car's computer system and triggers your dashboard indicator light. TPMS report real-time tire-pressure information to the driver of the vehicle, either via a gauge, a pictogram display, or a simple low-pressure warning light.



Fig.1.8 Tire Pressure Sensor

RESULT

The initial results that we have obtained so far is that the jack is fabricated according to the wiper motor and the jack takes a weight up to 100 kgs. But we need a motor of high power and low torque which is quite expensive so we are supporting one tire weight with 2 motors and 2 jacks. This has improved the weight lifting capacity and due to this the car tire can be lifted easily. In the software part, we have created an app which will help in giving command to the Arduino through which the jack will be lifted.

CONCLUSION

The existing design was modified by introduction of an electric motor in the power screw, connecting lead screw to the motor shaft, the electric switch connected to the motor and plugged to the automobile 12V battery source to generate power for the prime mover (motor), in order to make load lifting easier. In

this modified design, the power screw is rotated through the motor when electrical power flows through it. This automatic car jack will minimize the human efforts which is required to operate a jack manually and the pressure monitoring system will be a precautionary step to avoid a flat tire as it indicates the pressure level in the tires.

ACKNOWLEDGMENT

The outcome of this project required a lot of guidance and assistance from many people and we are extremely privileged to have got this all along through our project. We respect and thank Dr. Deepak Gawali, for giving us all support and guidance which made us understand our project better. We are extremely thankful to sir for providing such a nice support and guidance, although she had busy schedule. We owe our deep gratitude to our project guide Mrs. Deepti.G.Patne ma'am who took keen interest on our project work and guided us all along, by providing all the necessary information for developing a good system. Also, we would like to extend our sincere esteem to all Teaching staffs and staffs in laboratory for their timely support.

REFERENCES

- [1] <http://powerjacks.com/about-us/powerjackswhat-we-do.php>
- [2] Bhandari, V.B. (2009), —Design of Machine elementl, Tata McGraw-Hill Education.
- [3] RS Khurmi, A test book of Machine Design, Eurasia publishing house
- [4] Powerjack.com/downloads/Design%20
- [5] Guides/PJLMPT-02/S1-Screw-Jacks
- [6] PJLNIPIDG- 02.pdf
- [7] Rajput, R.K, (2007), —A Textbook of Manufacturing Technologyl, Laxmi
- [8] Publications,1st Edition, 899pp. ISBN: 978 -81 - 318 - 244 - 1.
- [9] <http://en.wikipedia.org/wiki/Jackscrew>
- [10] Academia...u/6167889/Modification_of_the_Existing_De sign_of_a_Car_jack.
- [11] http://ww.ijceronline.com/papers/Vol14_issue07/Version-1/A0470101011.pdf
- [12] Design and fabrication of motorized automated
- [13] Object lifting jack; IOSRJEN.ISSN(e):2250-3021.
- [14] IOSR Journal of Engineering (IOSRJEN)
- [15] www.iosrjen.org, ISSN (e): 2250-3021,ISSN(p): 2278-8719, VoL 04, Issue 07 (July.2014), and IIVI II PP 15-28