

# Automated License Controlled Vehicle with Air Pollution Monitor and Control

R. SharmilaGowri, <sup>1</sup>

Assistant Professor of ECE Department,  
Jayashriram Group of institutions,  
Avinashipalayam, Tamilnadu, India.

M. Gayathri, <sup>3</sup>

VIII Semester of BEECE,  
Jayashriram Group of institutions,  
Avinashipalayam, Tamilnadu, India.

K. Bhuvaneswari, <sup>2</sup>

VIII Semester of BEECE,  
Jayashriram Group of institutions,  
Avinashipalayam, Tamilnadu, India.

B. Kowsalya Devi, <sup>4</sup>

VIII Semester of BEECE,  
Jayashriram Group of institutions,  
Avinashipalayam, Tamilnadu, India.

**Abstract:** - In this paper Every License holder is provided with the RFID smart card collection of data extracted from License. This is a key for vehicle and this paper is to develop a compact system to detect and control the pollutants in the vehicle which could be assembled in the vehicle itself. This idea employs an gas sensors which is economical and capable of detecting Carbon Monoxide and other toxic gases emitted from the vehicle. Amount of toxic gases continuously display in LCD. Initial warning is given to the driver regarding the amount of toxic gases. In case of negligence then the particular License details (L.no) is extracted from RFID smart card and SMS was send to RTO (for cancellation) and with Proper intimation (SMS) the vehicle is automatically halted. Once license canceled by rto then the license isn't valid to start out the vehicle. PIC Micro controller is used to control and monitor the system.

**Keywords:** *Sensors, toxic gases and controller*

## I. INTRODUCTION

The inadequate burning in the motor of a vehicle prompts to emanation of various gasses adding to increment in the contamination and unfavorably influencing nature. Discovery and control of these gasses is a vital region of work. This outflow from vehicles can't be totally maintained a strategic distance from be that as it may, it unquestionably can be controlled. These are basic things to control so here we concoct an idea to lessen contamination and duplicate permit. As an answer for the above issues we mean to assemble an Automated license controlled vehicle with air pollution monitor and control .License holder Details extracted from RFID Smart card and gas spillage sensors is utilized to identify the lethal gasses rate in the smoke discharged by the vehicle because of burning of fuel in it. Smoke identifier is settled toward the finish of the Outlet of vehicle from where smoke is discharged into nature. The gas leakage sensor is identifies lethal gasses and offers it to the Micro controller to check the most extreme rate of dangerous content in the smoke discharged by vehicles. LCD is utilized to show the continuous level a of gas. So the controller checks the rate of lethal gas , on the off chance that it surpasses the limit level then the license number removed from the RFID Smart card and License number send to where permit enrolled RTO for

cancelation and with the best possible notice SMS to client. At that point framework gets activated and motor comes to halt state

## II. LITERATURE SURVEY

Throughout the years, there have been a few directions made by the Government to control the emanation from vehicles and copy permit the vast majority of them being unsuccessful at the same. The benchmarks and the course of events for usage are set by the Central Contamination Control Board under the Ministry of Environment and Forests. Bharat arrange discharge models are emanation guidelines established by the Government of India to direct the yield of air Pollutants from interior burning motor gear, including engine vehicles. The primary outflow standards were presented in India in 1991 for petrol and 1992 for diesel vehicles. These were trailed by making the Catalytic converter required for petrol vehicles and the presentation of unleaded petrol in the market. On April 29, 1999 the Supreme Court of India decided that all vehicles in India need to meet Euro I or India 2000 standards by June 1, 1999 and Euro II will be required in the NCR by April 2000. Auto creators were not set up for this move and in an ensuing judgment the usage date for Euro II was not upheld. The measures, in view of European controls were initially presented in 2000. Logically stringent standards have been taken off from that point forward. Every single new vehicle made after the usage of the standards must be consistent with the directions. Since October 2010, Bharat arrange III standards have been implemented over the nation. In 13 noteworthy urban areas, Bharat arrange IV discharge standards are set up since April 2010. In this paper, the semiconductor sensors have been utilized to recognize the poison level of the vehicles. This Paper focuses for the most part on three pieces; smoke identifier, smaller scale controller and fuel injector. The smoke finder recognizes the toxins (CO, NOx, and so on.) consistently. The smaller scale controller contrasts the level of contaminations and the stipulated level permitted by the administration. At the point when the poison level surpasses as far as possible, it sends a flag to the fuel injector. On accepting a flag from the controller, the fuel injector stops the fuel supply to the motor after a specific timeframe.

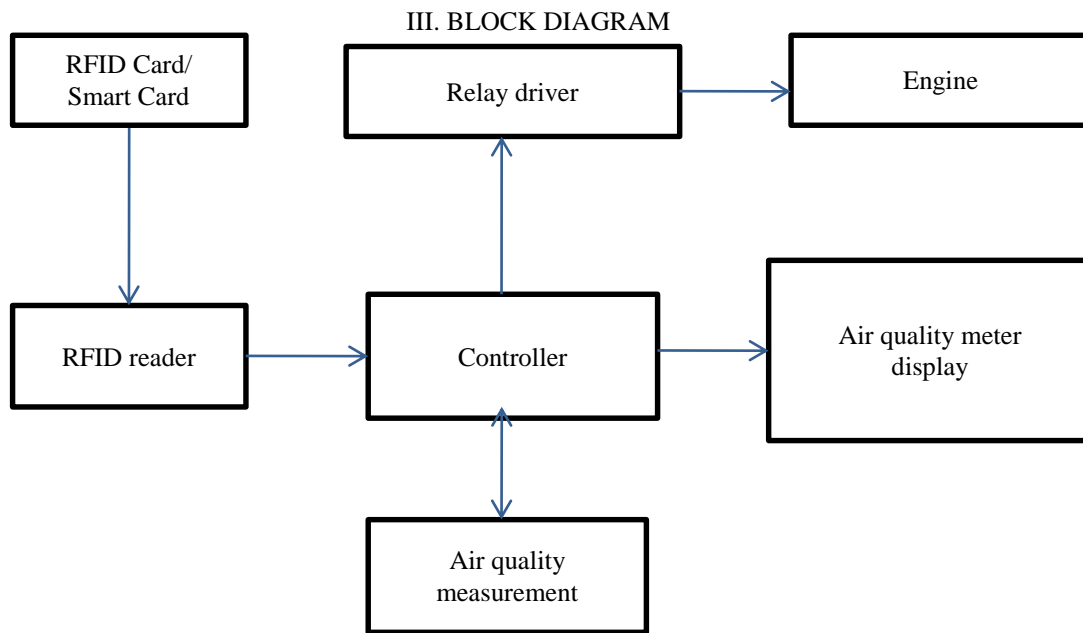

Fig.1 General block diagram of the system

III A ) BLOCK DISCRIPTION

a. RFID Card/Smart card

Radio-recurrence ID (RFID) utilizes electromagnetic fields to naturally distinguish and track labels connected to objects. The labels contain electronically put away data. Latent labels gather vitality from a close-by RFID per user’s examining radio waves. Dynamic labels have a nearby power source, for example, a battery and may work at several meters from the RFID peruse. Not at all like a standardized tag, the label require not be inside the viewable pathway of the peruse, so it might be implanted in the followed protest. RFID is one technique for Automatic Identification and Data Capture (AIDC)

RFID labels are utilized as a part of numerous ventures, for instance, a RFID label appended to a car amid generation can be utilized to keep tabs on its development through the mechanical production system; RFID-labeled pharmaceuticals can be followed through distribution centers; and embedding RFID microchips in domesticated animals and pets permits positive distinguishing proof of creatures.

b. RFID Reader

EM-18 RFID Reader is used to read the RFID tag license which we are going to use a key for vehicle. we can divide RFID devices into two classes: active and passive This is a low recurrence (125Khz) RFID reader with serial yield with at scope of 8-12cm. It is a reduced units with inherent reception apparatus and can be specifically associated with the PC utilizing RS232 convention. show your license with in the reading distance and the card number is thrown at the output in LCD display.

C. CONTROLLER

PIC13F877A is a micro controller used to control and monitor the whole system PIC stands for peripheral interface controller

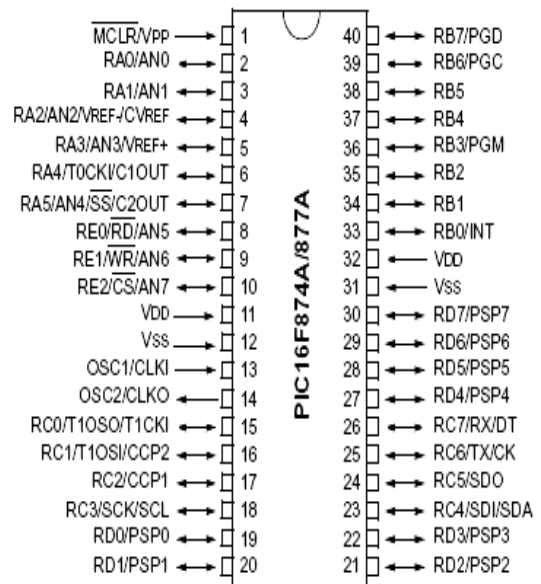

Fig 2 pin diagram of Pic 16f877a

Only 35 single-word instructions to learn .All single-cycle instructions except for program branches, which are two-cycle. Its Operating speed is DC – 20 MHz clock input DC – 200 ns instruction cycle It can store Up to 8K x 14 words of Flash Program Memory, Up to 368 x 8 bytes of Data Memory (RAM), Up to 256 x 8 bytes of EEPROM Data Memory

d. Air quality measurement

Gas sensors MQ 7 and MQ 2 are used to sense the gases from vehicle sensors were fixed in outlet of the vehicle. A gas indicator is a gadget which identifies the nearness of different gasses inside a zone, for the most part as a component of a framework to caution about gasses which may be unsafe to people or creatures. Gas indicators can be utilized to identify flammable, poisonous, and oxygen' and CO gasses. Perfect sensor for use to identify the nearness of an unsafe LPG spill in your auto or in an administration station, stockpiling tank condition. This unit can be effectively fused into a caution unit, to sound an alert or give a

visual sign of the LPG focus. The sensor has brilliant affectability joined with a speedy reaction time. The sensor can likewise detect iso-butane, propane, LNG and tobacco smoke. It detects Range: 100 - 10,000 ppm(part per milli) iso-butane propane. Here the comparator is made with operational electronic equipment luminous flux unit 358. The reference voltage is given to inverting input terminal. The reference voltage is depends on the specified gas intensity, once there's no discharge the non inverting input is kitchen utensil then inverting input therefore the output of the comparator is positive voltage that is given to the bottom of the switch semi conductor device the switch semiconductor device B.C. 547. thence the semi conductor device is conducting. Here the semiconductor device is act as switch therefore the collector and electrode are going to be closed. The output is taken from collector terminal. currently the output is zero that is given to hex electrical converter 40106.

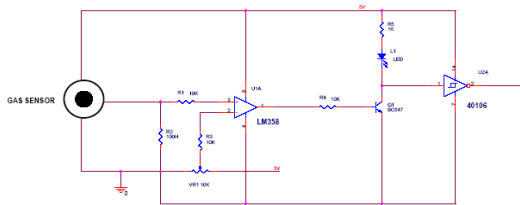

Fig 3 gas detector circuit



Fig 4 MQ7 sensor

When there's gas run the inverting input voltage is kitchen utensil than non inverting input. currently the comparator output is -12V therefore the semiconductor unit is cutoff region. The 5v is given to hex electrical converter 40106IC. Then the ultimate output knowledge is directly given to the controller to work out the gas run. Then this device is exposed to the pollutants its physical phenomenon will increase generating a symptom within the circuit that disables the engine.

Predefined value

Pollutant	Permissible Limit
Nitrogen Dioxide	60-80g/M3
Carbon Monoxide	2-4mg/M3
Sulphur Dioxide	60-80g/M3

*c. Air quality display*

LCD(Liquid crystal show) is employed to display the Characters, we have a tendency to area unit explosion the liquid crystal display that is 16X2, that's it ill show the sixteen characters in two rows. Its Command management the controller is in liquid crystal display.

*d. Relay driver*

This relay gets signal from PIC16F877. The relays ar connected with the ability path of the trains. If it gets 5volts signal from PIC16F877 the relay works. For relay driving here

use BC 547 semiconductor as a switch , for on and off the relay. The relay coil work with 12v dc provide.

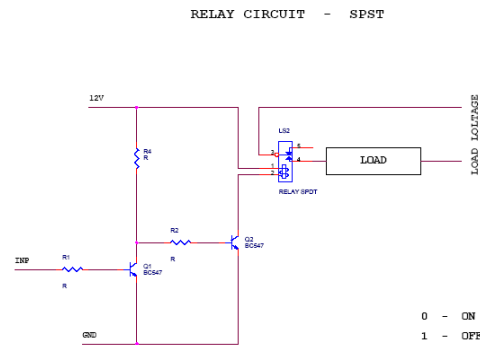

Fig 5 relay circuit

A relay is associate degree electrically operated switch. Current flowing through the coil of the relay creates a flux that attracts a lever and changes the switch contacts. The coil current is on or off thus relays have 2 switch positions and that they are double throw (changeover) switches. Relays enable one circuit to modify a second circuit which might be fully break away the primary, as an example an occasional voltage battery circuit will use a relay to modify a 230V AC mains circuit. there's no electrical association within the relay between the 2 circuits; the link is magnetic and mechanical.

IV SIMULATION RESULT AND DISCUSSION

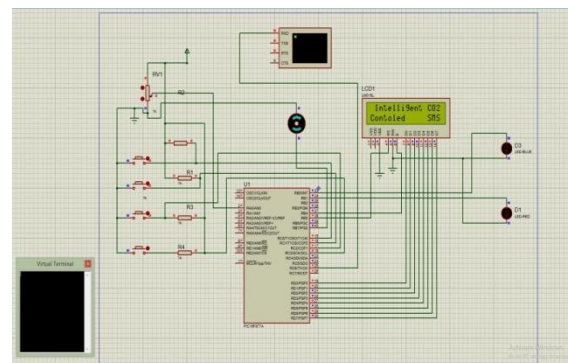
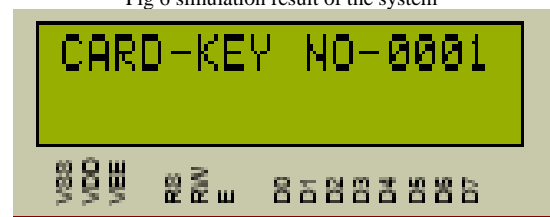

Fig 6 simulation result of the system



accessed RFID license



Continuous display of air pollutant level

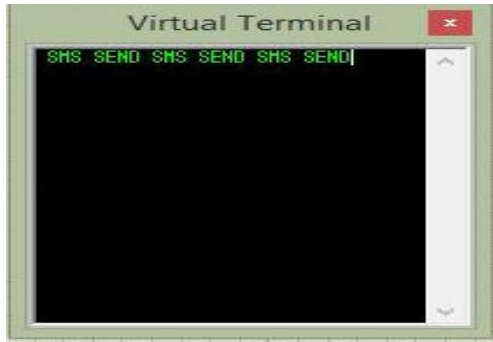

Engine stop message automatically send to RTO and RFID license holder

Pollution levels	Output voltage	Engine condition
300ppm	0V	ON
350ppm	0.5V	ON
400ppm	0.95V	ON
450ppm	1.35V	ON
500ppm	1.79V	ON
550ppm	2.30V	ON
600ppm	3V	ON
650ppm	3.45V	INTIMATION
700ppm	3.88V	INTIMATION
750ppm	4.4V	INTIMATION
800ppm	4.98V	OFF

The table below shows the sample of results obtained from the system

V. FUTURE SCOPE

The paper certainly provides Associate in Nursing innovative answer to regulate pollution and vehicle theft and duplicate license. With in the close to future each vehicle can have its own air pollution control system which can benefit to government to control pollution and global farming.

VII.CONCLUSION

The construct of sleuthing the amount of Pollution and control duplicate license .there's a rise with in the level of Pollution over the last number of decades, resulting in many Environmental issues. There'll be a large population, who don't look out of the pollution from their vehicles seriously, that has already resulted in many environmental issues in like ozonosphere depletion. then this technique are extremely useful in curbing this downside

REFERENCES

[1] [http://wikipedia.org/wiki/Bharat\\_Stage\\_emission\\_standards](http://wikipedia.org/wiki/Bharat_Stage_emission_standards)  
 [2] [https://en.wikipedia.org/wiki/Smart\\_card](https://en.wikipedia.org/wiki/Smart_card)  
[https://en.wikipedia.org/wiki/Radio-frequency\\_identification4](https://en.wikipedia.org/wiki/Radio-frequency_identification4) .Global Warming Signs [Date accessed: Jul. 2011]. [Online]. Available :<http://www.johndaly.com/ges/msl-rept.htm>  
 [3] "Trade of Motor Mechanic"; Module 5; Unit 2 Electronic Fuel injection; Phase 2 by FÁS Learning Innovation Unit with Martin McMahon & CDX Global; Curriculum Revision 2.2 16-01-07.  
 [4] V. Petrascu, G. Czibula, D. Sirbu, M. Popa, and D. Curseu, "Identifying the impact of global warming on population using a clustering-based approach," in Proc. IEEE AQTR, Cluj-Napoca, Romania, May 2010, pp. 1–6.  
 [5] GengJuntato, Zhou Xiaotao, Zhang Bingjie, "An Atmosphere Environment Monitor System Based on Wireless Sensor Network", Journal of Xihua University, Natural Science, Vol. 26, no.4, pp. 44-46 ,2007.