

Application of Multilevel Inverter Using SVPWM on High Performance Drive

¹Ashish Srivastava, ²Prof. Bharti Dwivedi, ³Dr. Anurag Tripathi

¹Sr. Lecturer, MPEC, Kanpur, ²Professor, IET Lucknow, ³Associate Professor, IET Lucknow

Abstract

Multilevel converters produce excellent line-side and load-side performances such as nearly sinusoidal line-currents at unity power factor and regulated and reduced-rippled load voltage, the neutral point of the neutral-point clamped converters is prone to fluctuations due to the irregular charging and discharging of DC-bus capacitors. This causes the unbalanced DC-bus capacitor voltages which, if not balanced, cause large voltage stress on some devices which may exceed the manufacturers' specifications and may deteriorate the source current for large voltage unbalances, thus offsetting the advantages offered by these converters. To address this issue, a modified space vector modulation strategy (voltage balancing strategy) is designed and investigated in the next stage. The voltage balancing algorithm identifies the switching states responsible for producing the capacitor voltage unbalance and then uses the redundant switching states for balancing the capacitor voltages. This algorithm perfectly balances the DC-bus capacitor voltages which further improves the performance of converter by reducing the line-current THD. The performance of converter using the voltage balancing control algorithm is evaluated for fixed and variable supply voltage and load conditions, unbalanced load conditions and under the operation with distorted mains.

Key words: Multi level inverter, SVPWM.

1. Introduction

The multilevel inverters have drawn tremendous interest in the power industry. They present a new set of features that are well suited for use in reactive power compensation. It may be easier to produce a high power, high voltage inverter with the multilevel structure because of the way in which device voltage stresses are controlled in the structure. Increasing the number of voltage source inverters allows them to reach high voltages with low harmonics without the use of transformers or series connected synchronized switching devices. As the number of voltage levels increases, the harmonic content of the output voltage waveform decreases significantly.

Medium Voltage adjustable-Speed-drive (MV-ASD) system offers significant advantages in a wide range of industrial applications such as pump, fan, and many improved process control systems with higher efficiencies combined with energy saving. The induction motor drives present an attractive solution because they are cheapest and rugged. One aspect of CML inverter apart from the three-level NPC inverter is to utilize small inverter bridges with respectively low voltage to synthesize and reach high voltage, thus is more suitable for high-voltage, high-power applications.

For the NPC inverters, a variety of modulation strategies have been reported, with the most popular being carrier-based pulse-width modulation (SPWM), space vector modulation (SVPWM). Another issue about the CML configuration is the internal voltage drop from the cascaded series connection of the insulated-gate bipolar transistor (IGBT)-diode modules, which becomes substantially high at low speeds when the output voltage is respectively low. The internal voltage drop causes voltage and current distortions at low speed when the voltage is low.

IGBTs able to support a voltage of 6.5kV are now available; however, the commutation speed of 6.5kV IGBTs is rather lower than that of 3.3kV IGBTs, available since some years. Therefore, in high-voltage converter it is still convenient to employ a Neutral Point Clamped (NPC) structure based on 3.3kV IGBTs. NPC inverters halve the maximum drop voltage on their devices because they are built up of four switches per phase, furnish a three-level voltage output and improve the current tracking performances in current control loops; moreover, they present a better harmonic content of the current than traditional VSI, allowing a torque ripple reduction.

2. VECTOR CONTROL OF INDUCTION MOTOR

Vector control, also called field-oriented control (FOC), is a variable frequency drive (VFD) control method which controls three-phase AC electric motor output by means of three controllable VFD inverter output variables:

- Voltage magnitude
- Voltage angle
- Frequency.

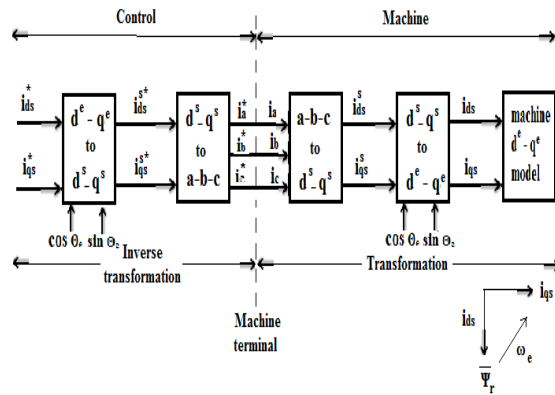

Fig 2.8 Vector control implementation principle

FOC is a control technique used in AC synchronous and induction motor applications that was originally developed for high-performance motor applications which can operate smoothly over the full speed range, can generate full torque at zero speed, and is capable of fast acceleration and deceleration but that is becoming increasingly attractive for lower performance applications as well due to FOC's motor size, cost and power consumption reduction superiority.

Not only is FOC very common in induction motor control applications due to its traditional superiority in high-performance applications, but the expectation is that it will eventually nearly universally displace single-variable scalar volts-per-Hertz (V/Hz) control.

In vector control, an AC induction motor is controlled under all operating conditions like a separately excited DC motor. That is, the AC motor behaves like a DC motor in which the field flux linkage and armature flux linkage created by the respective field and armature (or torque component) currents are orthogonally aligned such that, when torque is controlled, the field flux linkage is not affected, hence enabling dynamic torque response.

Vector control accordingly generates a three-phase PWM motor voltage output derived from a complex voltage vector to control a complex current vector derived from motor's three-phase motor stator current input through projections or rotations back and forth between the three-phase speed and time dependent system and these vectors' rotating reference-frame two-coordinate time invariant system.

Such complex stator motor current space vector can be defined in a (d,q) coordinate system with orthogonal components along d (direct) and q (quadrature) axes such that field flux linkage component of current is aligned along the d axis and torque component of current is aligned along the q axis. The induction motor's (d,q) coordinate system can be superimposed to the motor's instantaneous (a,b,c) three-phase sinusoidal system as shown in accompanying image (phases a & b not

shown for clarity). Components of the (d,q) system current vector, allow conventional control such as proportional and integral, or PI, control, as with a DC motor.

3. MODULATION TECHNIQUE

There are several different modulation technique which are as shown in fig. 3.1.

As in 3-level NPC inverter, modulation strategies can be framed into two main techniques:

- 1) Sinusoidal Pulse width Modulation technique
- 2) Space Vector Modulation technique
 - a. Open loop Control
 - b. Closed loop Control

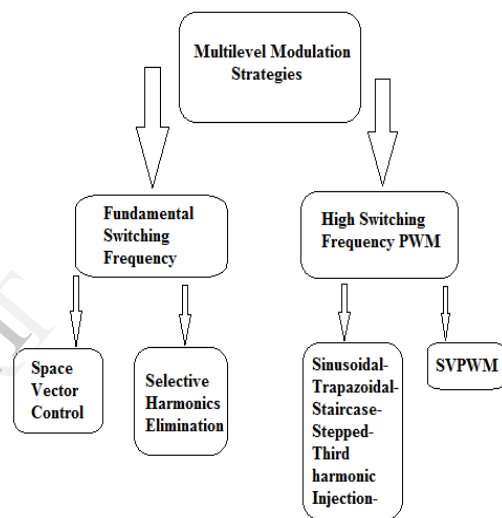

Fig. 3.1 Overviews of different modulation strategies

The first modulation techniques, widely used in industrial application, are based on the comparison, separately for each inverter phase, between suitable analogical signals. Therefore the commutation instants of the IGBT are determined by the comparators outputs, e.g. from the modulated of the signals applied to the comparators. SVM techniques, instead, determine the modulated waveforms taking into account simultaneously the desired voltage for all the inverter phases.

4. MULTILEVEL STRATEGIES

A multilevel inverter works with the usage of several levels of DC-voltages constructing a staircase formed AC-voltage. Capacitors, batteries and renewable energy sources can be used as the DC- source. When the voltage level increases the harmonics decreases. The advantage of this multilevel system is that it induces good power quality, has good electromagnetic compatibility, low switching losses and high capability. There are also several methods in decreasing the switching losses even more. Excepts for these advantages, the multilevel is characterized by low distortion

and low dv/dt (voltage variation in time) in the output, low current distortion. It also gives the possibility to terminate common-mode (CM) voltages (and so reducing the stress on the bearings) and is operational with both low and high switching frequencies. High switching frequency means higher efficiency. Unfortunately, multilevel converters do have some disadvantages. One particular disadvantage is the greater number of power semiconductor switches needed. Although lower voltage rated switches can be utilized in a multilevel converter, each switch requires a related gate drive circuit. This may cause the overall system to be more expensive and complex. This chapter will describe the Diode Clamped Multilevel Converters. Also, voltage control operations will be discussed.

The simulation tests were performed taking into account a Field Oriented Controlled drive employing a neutral-point clamped inverter. and Induction motor of rating 5HP, 460V, 50Hz at different torque input.

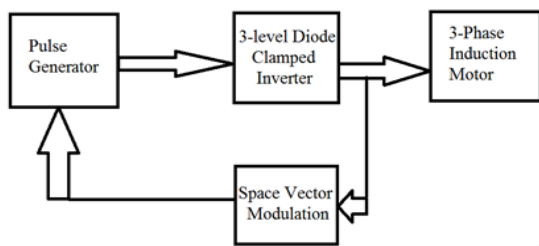

Fig. 5.1 Block Diagram of induction motor fed by NPC inverter

5. MODEL FOR NPC INDUCTION MOTOR DRIVE

Fig 5.1 shows the main circuit configuration of the NPC fed PWM induction motor drives. It basically consists of the parts named as NPC, pulse generation section, vector control unit, and induction motor. All the components are described as following in various headings.

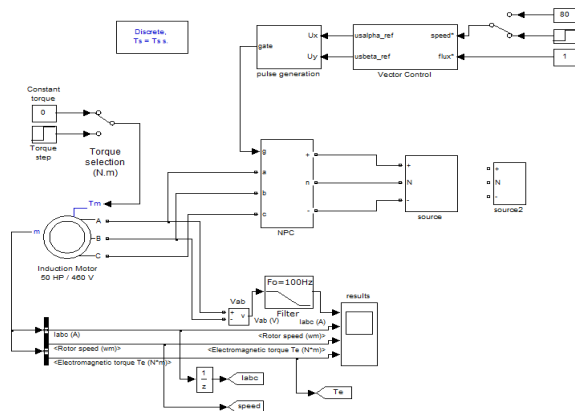

Fig. 5.1 Simulation of Main model

The basic vector control unit is as shown in fig 5.4

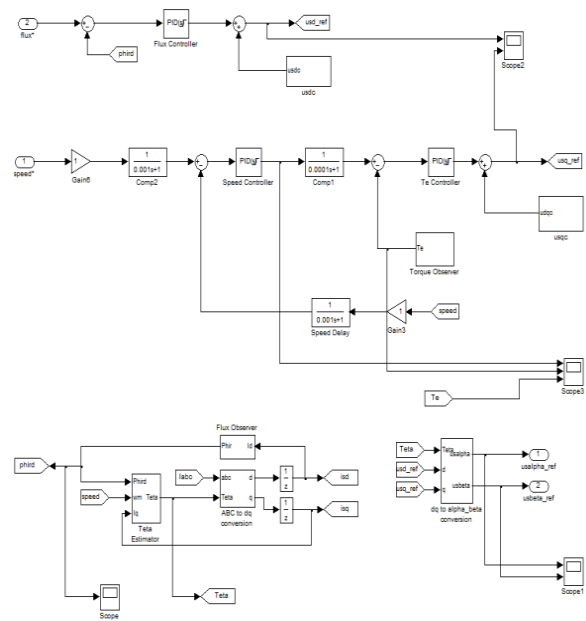

Fig 5.4 Vector Control

The Pulse generation contains sector generation, Switching time calculations section and Switching time calculation for sector as shown in figure given below. The basic programs for these sectors are given in Appendix-I.

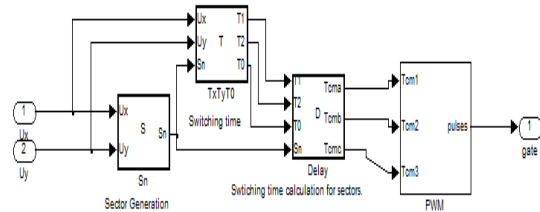

Fig 5.5 Pulse Generation

The basic Simulink model of an NPC inverter is as shown in fig 5.6. The basic of the operation of this inverter is SVPWM technique.

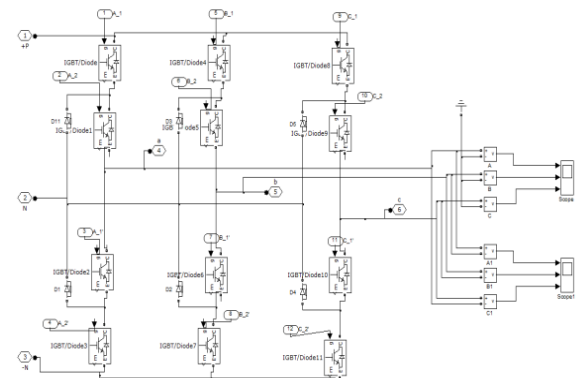

Fig. 5.7 NPC

6. RESULTS

6.1.1 CONSTANT TORQUE AND CONSTANT SPEED CONDITION

In such condition the operation is taken place for a constant value of torque and speed. we select the value of torque as a constant value ($= 0 \text{ N-m}$), whereas speed selected as (80rad-s^{-1}). The response is shown in fig 5.9. It is clear that initially during transient period the torque contains an average value of 200N-m at and the value of rotor speed goes on increasing from 0rad-s^{-1} to 80rad-s^{-1} . At the instant at which speed reaches the selected value ($= 80\text{rad-s}^{-1}$) system enters in steady state conditions and waveforms of currents goes on smooth. At this instant after some fluctuations the value of torque reaches its selected value ($=0\text{N-m}$).

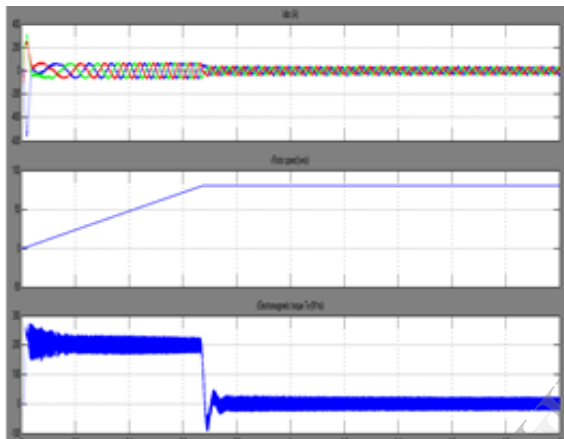

Fig 5.9 Result for Constant torque and constant Speed condition

6.1.2 CONSTANT TORQUE AND VARIABLE SPEED CONDITION

we select the value of torque as a constant value (0 N-m), whereas speed varies from 80rad-s^{-1} to 140rad-s^{-1} and the step time for the operation is selected as 1.5s . The response of the result is as shown in fig 5.11. It is clear that initially during transient period the torque contains an average value of 200N-m at and the value of rotor speed goes on increasing from 0rad-s^{-1} to 80rad-s^{-1} . At the instant at which speed reaches the selected value ($= 80\text{rad-s}^{-1}$) system enters in steady state conditions and waveforms of currents goes on smooth. At this instant after some fluctuations the value of torque reaches its selected value ($= 0\text{N-m}$). As we select the step time 1.5s so speed again goes on change from 1.5 sec (from 80rad-s^{-1} to 140rad-s^{-1}), during this speed change torque again changes and attains an average value of 200N-m system again enters in transient condition whenever its speed reaches final speed ($= 140\text{rad-s}^{-1}$).

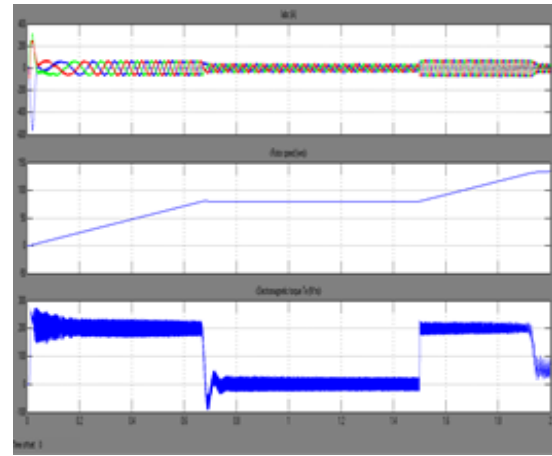

Fig 5.11 Result for Constant torque and variable Speed condition

6.1.3 VARIABLE TORQUE AND CONSTANT SPEED CONDITION

we select the variable torque values where as speed selected as constant value 80rad-s^{-1} and the step time for the operation is selected as 1.8s . The response of the result is as shown in fig 5.13. It is clear that initially during transient period the torque contains an average value of 200N-m at and the value of rotor speed goes on increasing from 0rad-s^{-1} to 80rad-s^{-1} . At the instant at which speed reaches the selected value ($= 80\text{rad-s}^{-1}$) system enters in steady state conditions and waveforms of currents goes on smooth. At this instant after some fluctuations the value of torque reaches its selected value ($= 0\text{N-m}$). As we select the step time 1.8s and final value of the torque as 200N-m so torque again changed from 0N-m to an average value of 200N-m as shown and during this situation speed goes somewhat decreasing.

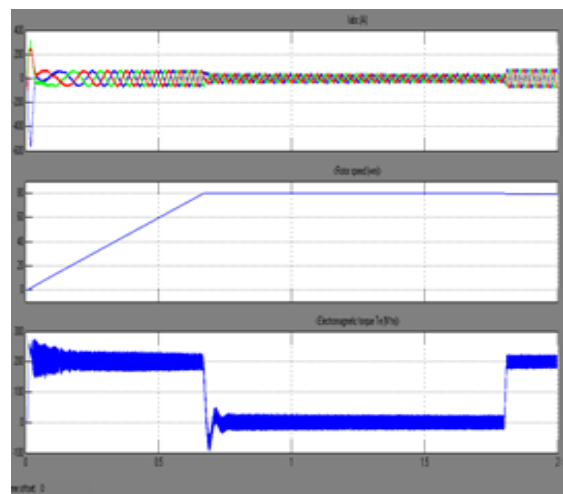

Fig 5.13 Result for variable torque and constant Speed condition

6.1.4 VARIABLE TORQUE AND VARIABLE SPEED CONDITION

The response of the result is as shown in fig 5.15. It is clear that initially during transient period the torque contains an average value of 200N-m and the value of rotor speed goes on increasing from $0\text{rad}\cdot\text{s}^{-1}$ to $80\text{rad}\cdot\text{s}^{-1}$ (as its selected initial value). At the instant at which speed reaches the selected value ($= 80\text{rad}\cdot\text{s}^{-1}$) system enters in steady state conditions and waveforms of currents goes on smooth. At this instant after some fluctuations the value of torque reaches its selected value ($= 0\text{N}\cdot\text{m}$). As we select the step time 1.8s is for torque and final value of the torque as 200N-m. The step time is selected for speed variation is as 1.5 s so at this instant the value of speed again goes on increasing (from $80\text{rad}\cdot\text{s}^{-1}$ to $140\text{rad}\cdot\text{s}^{-1}$)

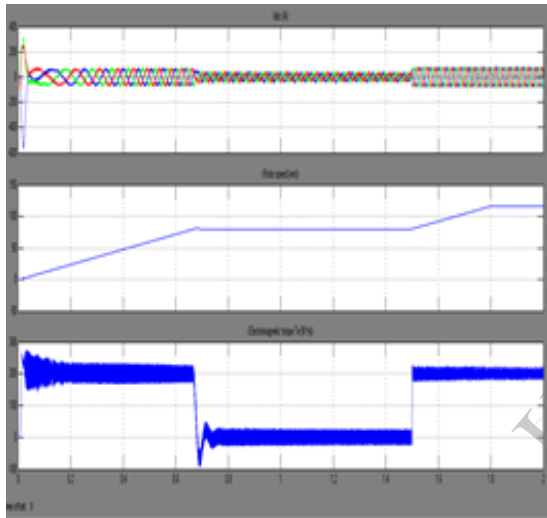

Fig 5.15 Result for variable torque and variable Speed condition

7. Conclusion

The results shows that the performance of induction motor under space vector pulse width modulation technique give precise control of speed & torque with reduced total harmonic distortion. The paper included Performance Comparisons of Modulation Technique for Induction Motor fed by Diode-clamped Neutral-Point-Clamped Inverter. The proposed pulse-rotation method, using single carrier instead of multi carriers, together with pulse decode, provided an effective pulse-control method for the diode-clamped NPC inverter. The comparison has shown that the proposed SVM always produces a smaller harmonics distortion; besides, it presents a lesser limitation on the maximum value of the output voltage module than the SPWM. We can apply this method for higher level multilevel inverters which reduces THD of the supply system.

8. APPENDIX-I

MATLAB CODE TO GENERATE SWITCHING FUNCTIONS

(a) SWITCHING STATES (sector generation)

```
function Sn = S(Ux,Uy)
theta=atan2(Uy,Ux)*180/pi;
if theta>=0&&theta<60
Sn=1;
elseif theta>=60&&theta<120
Sn=2;
elseif theta>=120&&theta<180
Sn=3;
elseif theta>=-180&&theta<-120
Sn=4;
elseif theta>=-120&&theta<-60
Sn=5;
else Sn=6;
end
```

(b) SWITCHING TIME

```
function [T1,T2,T0]=T(Ux,Uy,Sn)
Ts=1/2000;
Udc=530;
X=sqrt(3)*Ts/Udc*Uy;
Y=sqrt(3)*Ts/2/Udc*(sqrt(3)*Ux+Uy);
Z=sqrt(3)*Ts/2/Udc*(-sqrt(3)*Ux+Uy);
```

```
if Sn==1
T1=-Z;T2=X;
elseif Sn==2;
T1=Z;T2=Y;
elseif Sn==3;
T1=X;T2=-Y;
elseif Sn==4;
T1=-X;T2=Z;
elseif Sn==5;
T1=-Y;T2=-Z;
else T1=Y;T2=-X;
end
```

```
if T1+T2>Ts
a=T1;b=T2;
T1=a*Ts/(a+b);
T2=b*Ts/(a+b);
end
```

```
T0=Ts-T1-T2;
```

(c) SWITCHING TIME CALCULATION FOR SECTORS

```
function [Tcma,Tcmb,Tcmc]=D(T1,T2,T0,Sn)
T=1/2000;
Udc=530;
ton1=0.25*T0;
```

```

ton2=ton1+T1/2;
ton3=ton2+T2/2;
ifSn==1
Tcma=ton1;Tcmb=ton2;Tcmc=ton3;
elseifSn==2;
Tcma=ton2;Tcmb=ton1;Tcmc=ton3;
elseifSn==3;
Tcma=ton3;Tcmb=ton1;Tcmc=ton2;
elseifSn==4;
Tcma=ton3;Tcmb=ton2;Tcmc=ton1;
elseifSn==5;
Tcma=ton2;Tcmb=ton3;Tcmc=ton1;
elseTcma=ton1;Tcmb=ton3;Tcmc=ton2;
end

```

9. Reference

- [01] Jih-Sheng Lai and Fang ZhengPeng, "Multilevel Converters- A New Breed of Power Converters" IEEE Trans. Ind. Electron., vol. 32, no. 3, pp. May/June 1996.
- [02] G. Mondal, K. Srivakumar, R. Ramachandra, K. Gopalkumar, and E. Levi, "A dual seven-level inverter supply for a an open-end winding induction motor drives," IEEE Trans. Ind. Electron., vol. 56, no. 5, pp. 1665-1673, May 2009.
- [03] O. Lopez, J. Alvarez, J. Dovel-Gondoy, and F. D. Freijedo, "Multilevel multiphase space vector PWM algorithm," IEEE Trans. Ind. Electron., vol. 55, no. 5, pp. 1933-1942, May 2008.
- [04] B. P McGrath, D.G. Holmes, "Multicarrier PWM strategies for multilevel inverters," , IEEE Trans. Ind. Electron., vol. 49, no. 4, pp. 858-867, Aug 2002.
- [05] A Mahfouz, J Holtz, A El-Tobshy, "Development of an Integrated High Voltage 3-Level Converter-Inverter system with sinusoidal input output for feeding 3-phase induction motors",Cairo University, Egypt, Wuppertal University, Germany.
- [06] Mario Marchesoni and PierluigiTenca, "Diode-Clamped Multilevel Converters: A Practicable way to balanced DC-Link Voltages", IEEE Trans. Ind. Electron., vol. 49, no. 4, Aug 2002.
- [07]Subrata K. Mondal, Joao O. P. Pinto and Bimal K. Bose, " A Neural-Network-Based Space-Vector PWM Controller for a Three-Level Voltage-fed Inverter Induction mptor Drive", IEEE Trans. Ind. Electron., vol. 38, no. 3, pp. May/June 2002.
- [08]Tadros, Y. Salama, A. Hof. R, "Three Level IGBT Inverter", AEG Aktiengesellschaft, Institute of Drive Systems and Power Electronics Culemeyerstrabe 1, D-1000 Berlin 48, Germany.
- [09] Dongsheng Zhou (Medium Voltage Division/Rockwell Automation 6400W Enterprise/ Mequon, WI53092 USA) and Didier Rouaud (Siemens E & A/Driver Division 100 Technology Dr. STE 102/Alpharetta, GA 30005), " Experimental Comparisons of Space Vector Neutral Point Balancing Strategies for Three-Level Topology".
- [10] Emmanuel DELALEAU, Jean- Paul LOUIS, Romeo ORTEGA, "Modeling and Control Of Induction motors" Int. J. Appl. Math. Comput.Sci, 2001, Vol.11, No.1, 105-129.
- [11]Ashok Kusagur, Dr. S.F. Kodad, Dr. B.V. Sankar Ram, "Modelling of Induction Motor & Control Of speed Using Hybrid Controller Technology" Journal of Theoretical and Applied Information Technology.
- [12]Dal Y. Ohm (Drivetech, Inc., Blacksburg, Virginia); DYNAMICS MODEL OF INDUCTION MOTORS FOR VECTOR CONTROL.
- [13]High Performance Control Of Ac Drives with MATLAB SIMULINK MODEL; Haitham Abu-Rub, AtifIqbal, JaroslawGuzinski, Ed. 2012. Wiley Publications.
- [14] Advance Power Electronics and Ac Drives, Ned Mohan.
- [15] Power Electronics and Ac Drives; B.K Bose.