

ADJUSTABLE SPEED SYSTEM OF INDUCTION MOTOR USING VECTOR CONTROLLED

P.Deepthi

Department of Electrical and Electronics
Shri Vishnu Engineering College for Women
Bhimavaram, India.

Abstract:: *In the field of induction motor control theory vector control is the high performance method which is most widely used. The construction of the motor control system is based on the analysis of induction motor dynamic mathematical model and the vector control principle. The basic principle is based on the coordinate transformation theory, in which two orthogonal ac components in time phase are converted into two orthogonal dc components in space. The organic integration of functional modules, the vector control induction motor system has been constituted. Asynchronous AC induction motor module, the vector controller module, Park transform module, inverter module, module flux, as well as current control, speed-conditioning module have been set up by adopting the idea of modular in Matlab / Simulink environment. The changes in the motor load torque, the dynamic changes of speed curve, which demonstrate that the real system can be well simulated with fast dynamic response speed, steady-state small of static error, and strong ability of anti-load disturbance.*

Keywords: AC motor, vector control, MATLAB, Simulation

1. INTRODUCTION

AC Induction motor is widely used in the modern ac drive system, which has simple structure, low price, good durability and flowing capacity, and easily to be maintained. Nevertheless due to the nonlinear characteristics, such as high-order, nonlinear, multivariable and strong coupling, as compared with DC motor, AC induction motor cannot realize the high performance speed governing. With the development of power electronic technology and AC induction motor control theory, especially the appearance of DSP signal processor and ASIC, as well as the application of many control algorithm in the motion control field, such as vector control, direct torque control, adaptive control and speed sensorless control, the performance of AC speed regulation system is becoming more and more superior. AC induction motor has gradually replaced the traditional DC motor and becomes the mainstream of drive motor in transmission system, which plays a more extensive and important role in every field and department of people's daily life and in industry and agriculture. The basic principle is based on the coordinate transformation theory, in which two orthogonal ac components in time phase are converted into two orthogonal dc components in space. Then the AC induction motor stator currents is decomposed into two independent DC control quantity: excitation component and torque component, which are separately used to realize the control of motor magnetic flux and torque. Finally, two dc control quantity are reduced to ac variables to control the AC induction motor. Thus controlling magnetic flux and torque as DC motor is realized, which greatly improve the dynamic performance of speed governing. In this paper, based on the analysis of asynchronous motor dynamic mathematical model and the principle of vector control, the motor control system is constructed though vector control method. The simulation model of induction motor system has been built by Matlab/Simulink, and dynamic and static

Mrs.S.M.Padmaja

Department of Electrical and Electronics
Shri Vishnu Engineering College for Women
Bhimavaram, India.

performance of AC induction motor vector control speed regulation system has been validated via the simulation results.

II. MATHEMATICAL MODEL OF MOTOR

The mathematic model of AC induction motor is a highorder, nonlinear and strong coupling multivariable system, which needs to be simplified through coordinate transformation. By neglecting the space harmonic influence, magnetic saturation, iron loss and changes of frequency and temperature, the mathematical model of three-phase induction motor can be described on the d-q coordinate system by,

Voltage equation:

$$\begin{bmatrix} u_{1M} \\ u_{1T} \\ 0 \\ 0 \end{bmatrix} = \begin{bmatrix} r_1 + L_1 P & -\omega_1 L_1 & MP & -\omega_1 M \\ \omega_1 L_1 & r_1 + L_1 P & \omega_1 M & MP \\ MP & 0 & r_2 + L_2 P & 0 \\ \omega_s M & 0 & \omega_s L_2 & r_2 \end{bmatrix} \quad (1)$$

Flux linkage equation:

$$\begin{aligned} \Psi_{2M} &= \Psi_2 = L_2 i_{2M} + M i_{1M} \\ \Psi_{2T} &= 0 = L_2 i_{2T} + M i_{1T} \end{aligned} \quad (2)$$

Electromagnetic torque equation:

$$T = n_p M (i_{1T} i_{2M} - i_{1M} i_{2T}) \quad (3)$$

Then equation (4) can be deduced from (1), (2) and (3) as follows:

$$\begin{aligned} T &= n_p \frac{M}{L_2} \Psi_2 i_{1T} \\ \Psi_2 &= \frac{M}{T_2 P + 1} i_{1M} \end{aligned} \quad (4)$$

In equation (1-4), r_1 and r_2 are stator resistance; L_1 and L_2 are stator self-induction ; M is stator mutual inductance; u_{1M} and u_{1T} are the stator voltage of M axis and T axis; ω_s is slip angular frequency; ω_1 is synchronous rotation angular frequency; T is electromagnetic torque; i_{1M} , i_{1T} , i_{2M} and i_{2T} are stator currents, n_p is motor pole logarithm; Φ_2 is rotor flux linkage; Φ_{2M} and Φ_{2T} are the rotor flux linkage of M axis and T axis; P is differential operator.

III. SIMULATION MODEL OF VECTOR CONTROL

The simulation model diagram in Simulink can be obtained from the basic equation, as shown in Fig.1. ω is speed, T is

torque, $M T i$, i and $i p h i r a b c$, are the preset current and flux linkage separately. The system consists of squirrel-cage motor and IGBT FB converter, current compare pulse generator, Vector control linkage, preset flux linkage, speed controller, expectation speed.

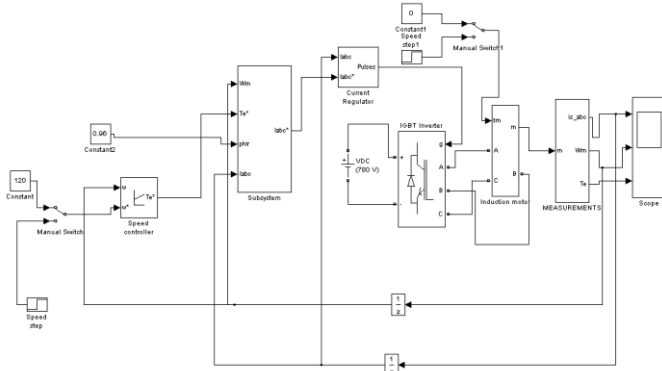

Fig.1 Simulink model for vector control of three phase motor

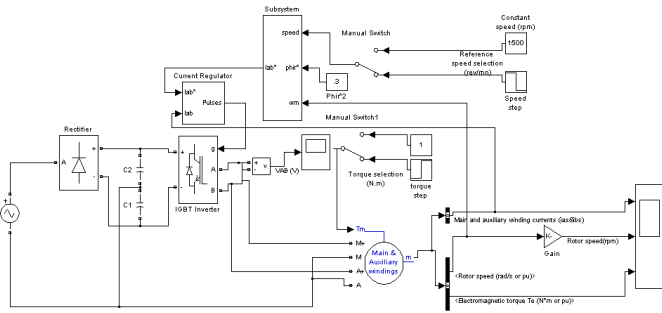

Fig.2: Simulink model for vector control of single phase motor

A. Induction Motor and Power Converter Module

The package structure of induction motor and power converter module is shown in Fig.1. Induction Machine SI Units module is adopted, which can simulate wound-rotor and squirrel induction motor in two-phase rotation coordinate system (including static two-phase coordinate system, rotor coordinate system and synchronous rotation coordinate system). A, B and C are the input terminal of three-phase induction motor stator windings, which connects with three output terminal of IGBT inverter, and constitute the induction motor sub-module power driven by inverter. As the access terminal of motor load, Tm is used to execute the motor loading experiment. Power converter module consists of six IGBT power tube and adopts Universal Bridge module which can simulate the inverter composed of GTO, MOSFET, THYRISTORS and IGBT, DIODES component. Inverter Pulses is the input terminal of six PWM control signals, and the DC bus voltage can input from “+” and “-” in inverter module.

B. Current Regulator Module

Current regulator can realize hysteresis tracking control of the induction motor three-phase current, the structure of which is shown in Fig.3. This module is composed of three hysteresis controllers (Relay) and three logical negation operators (Logical operator). The input is three-phase reference and measured current value, and the output is six PWM control signals. While No.1, No.3, No.5 control signal are complementary to No.2, No.4, No.6 control signal. This module can be constructed by the Relay and Logical operator module Simulink Library. Relay skips between logic 1 and logic 0 according to the changes of input signal. When the practical current is lower than reference current and the

differentials is bigger then hysteresis breaths of Relay, then the corresponding phase will forward break over (Relay output 1) and negative shutoff (Logical operator output 0); while the practical current is higher than reference current and the differentials is bigger then hysteresis breaths, then the corresponding phase will negative break over and forward Shutoff.

C. Co-ordinates Transformation Module

Coordinates transformation module include the transformation from three-phase static abc coordinate system to two-phase rotation dq coordinate system (Clarke and Park transformation) and transformation from two-phase rotation dq coordinate system to three-phase static abc coordinate system (inverse Park and inverse Clarke transformation). The transformation formula from dq to abc is:

$$i_a = i_{sd} \theta_s - i_{sq} \theta_s$$

$$i_b = \frac{i_{sd}}{2} (\sqrt{3} \sin \theta_s - \cos \theta_s) + \frac{i_{sq}}{2} (\sqrt{3} \cos \theta_s + \sin \theta_s) \quad (5)$$

$$i_c = -(i_a + i_b)$$

This module can be constructed through the user-defined function Fcn in Simulink Library, whose structure is shown in below figure.

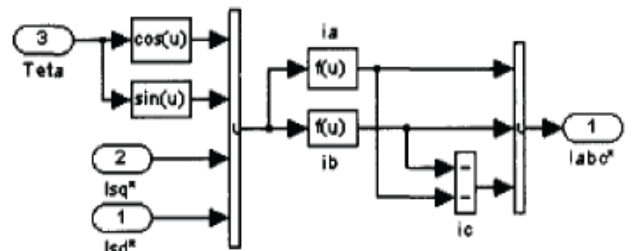

Fig.3 Transform module for dq to abc

The transformation formula from three-phase static abc coordinate system to two-phase rotation dq coordinate system is,

$$i_{sd} = \frac{2}{3} \left[i_a \cos \theta_c + \frac{1}{2} i_b (\sqrt{3} \sin \theta_c - \cos \theta_c) - \frac{1}{2} i_c (\cos \theta_c + \sqrt{3} \sin \theta_c) \right]$$

$$i_{sq} = \frac{2}{3} \left[-i_a \sin \theta_c + \frac{1}{2} i_b (\sqrt{3} \cos \theta_c + \sin \theta_c) + \frac{1}{2} i_c (-\sqrt{3} \cos \theta_c + \sin \theta_c) \right] \quad (6)$$

The realization structure of this module is given in below fig.4

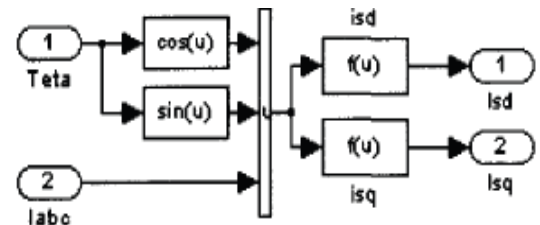

Fig.4 Transform module for abc to dq

IV.SIMULATION RESEARCH

Parameters of the asynchronous motor are set up as: rated power $n p = 500w$, rated voltage $n v = 460v$, pole logarithm $p n = 2$, stator resistance $R_s = 0.087 \Omega$, rotor resistance $R_r = 0.228 \Omega$, stator

inductance $L_s = 0.8 \text{ e-3 H}$, rotor inductance $L_r = 0.8 \text{ e-3 H}$, mutual inductance $L_m = 34.7 \text{ e-3 H}$. Simulation curve is given in Fig.5 for the condition that the given reference speed is 160rad/s, and the motor load is 300N.m. It includes line voltage, three-phase currents, load torque and motor speed. Line voltage is PWM wave whose amplitude equals to line voltage. The phase current peak is relatively large during the accelerating process, which is 2-3 times larger than the rated current. In the initial transient accelerated process, a rotating magnetic field is constructed and the three-phase current is not stable yet. When flux linkage reaches steady-state value, motor output the maximum torque and accelerate. The rise time is about 1 second. When the speed reaches steady-state value, then torque jump to zero, and the phase current keep steady, torque output maintain zero.

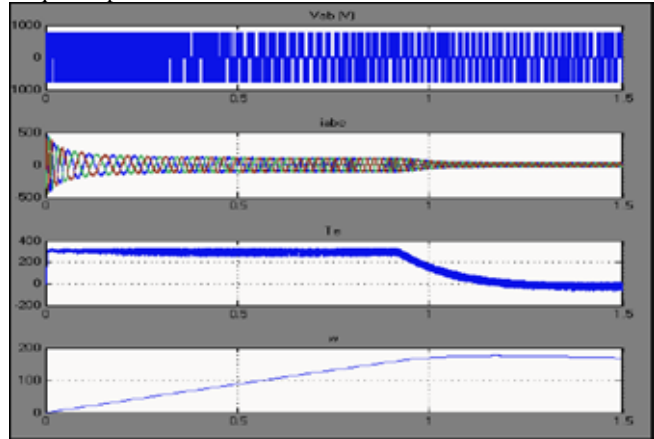

Fig5: simulation waveforms for phase voltage, current, load torque and speed with time when given speed is 160 rad/s

Fig.6 shows the simulation curve when initial speed changes from 160rad/s to 140rad/s. It is obvious that the peak speed appears at 0.3s which is about 165rad/s, after 1.5s it reaches to the given value 160rad/s. After 0.3s the load torque gradually descends from 300N.m to 0, and three-phase current achieve stability, then remain unchanged.

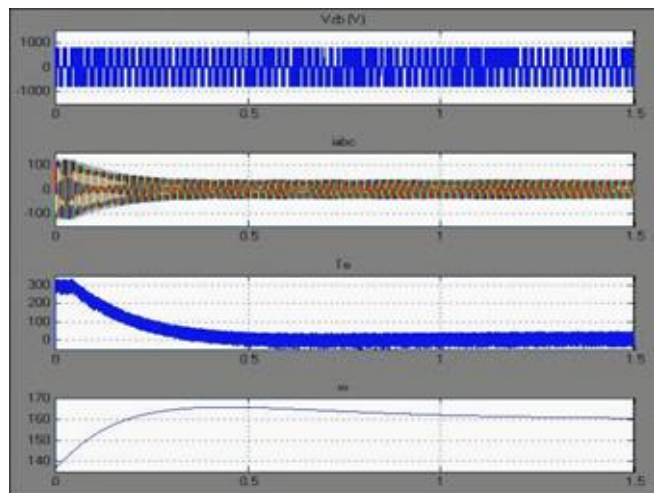

Fig.6 Simulation diagram when initial speed changes from 160 to 140

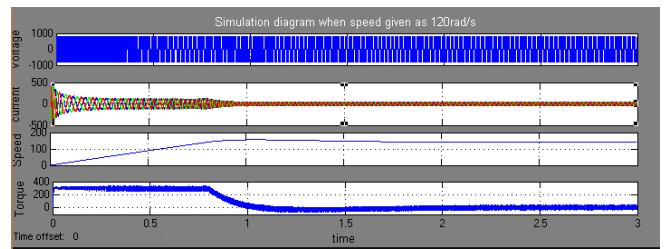

Fig.7 Simulation waveform for phase voltage, current, load torque and speed with time when speed is 120 rad/s

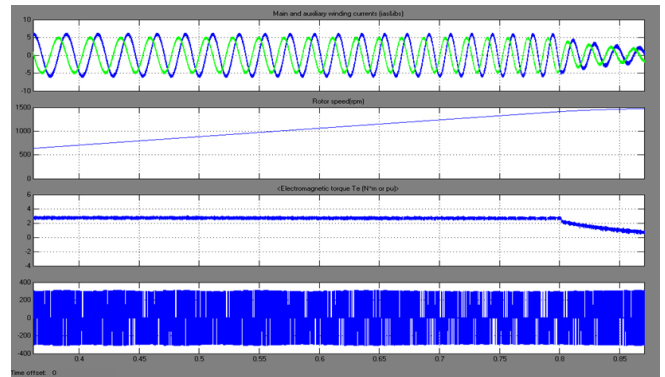

Fig.8 Simulation waveform for voltage, current, load torque and speed single phase induction motor using vector control

V.CONCLUSION

Based on the sufficient analysis of induction motor mathematical model and vector principle, simulation model in Matlab/Simulink environment has been constructed. The simulation results show that the dynamic response of the motor speed is fast, steady tracking has high precision, and the torque has instantaneous response characteristics, all of which are consistent with the theoretical analysis of vector control variable frequency speed regulation. Meanwhile this constructing method of simulation model is simple and convenient, which provides effective means for the realization and debugging in practical motor control system.

ACKNOWLEDGEMENT

I am thank full to my guide Mrs.S.M.Padmaja (Assoc. Prof) of EEE department for his valuable suggestion to complete my paper in time.

VI.REFERENCES

- [1] Rui Wang, Jin Zhao, Qin Deng, Yang Liu. Analysis and Experiment for Asynchronous Motor in Default of One Stator Phase. Journal of Electric Drive, Vo40, pp.13-15, September 2010 (In Chinese).
- [2] Bing Xiao, Qi Xue. Study of Asynchronous Motor Speed Sensorless Vector Control System Based on DSP. Journal of Electrical Automation, Vo32, pp.1-3, February 2010 (In Chinese).
- [3] Yichang Zhong, Lunlong Zhong, Feng Huang. Asynchronous motor vector control and realization based on SMVSC. Journal of Electrical Drive Automation, Vo54, pp.28-31, June 2009 (In Chinese).
- [4] F.Parasiliti, R.Petreia, and M.Tursini. Adaptive Sliding-mode Observer for speed sensorless control of induction motors. IEEE Trans.Ind. Applicat. Vol 46, pp128-137, February 1999.

- [5] Z.Yan, C.Jin, and V.I.Utkin. Sensorless Sliding-mode control induction motors. IEEE. Trans. Ind. Electronics, vol 47, pp 1286-1297, December 2000.
- [6] Vadim Lutkin. Sliding Mode Control Design Principles and Applications to Electric Drives. IEEE Trans., Vol 40, February 1993
- [7] B.K.Bose. Sliding mode control of induction motor. IEEE IAS Annu.meet. Conf. Rec., pp479-486, 1985
- [8] Baishan Mei, Wenqi Hu. Stator Flux Orientation Control of Asynchronous Motors with Stator Resistance Compensation. Journal of Electric machines control application, Vo37, pp.32-36, August 2010