

Smart Electronic System for CO₂ Emission Detection and Assessment

S. Thirumamani

Assistant Professor, Department of EEE, Sri Bharathi Engineering College for Women, Pudukkottai, India.

Abstract - The ever-increasing application of wireless sensor networks in many different fields is causing a growing demand of low-cost energy-efficient sensors for monitoring physical variables such as temperature, pressure or gas concentration. This paper presents a conditioning system for low-cost non-dispersive infrared gas sensors used to measure the CO₂ concentration in an open air environment. It mainly consists of amplification and filtering circuit that adapts the small and noisy signal provided by the sensor to a signal which can be easily read by a low-power microcontroller. The proposed interface presents a good trade-off between energy consumption and accuracy, compatible the energy requirements of wireless sensor network applications. Test performed connecting the system interface to a node sensor in a wireless sensor network using a simple communications protocol only causes a low reduction in the operating life of the node.

Key Words: Sensor interface, Carbon dioxide sensor, Smart sensor, Wireless sensor networks, NDIR sensor.

1. INTRODUCTION

The recent advances in mobile communications, joined to the ever-increasing reduction of the sensors size have made become a reality the use of low-cost low-power sensor networks in widely diverse environments. They offer a broad range of innovative applications [1], such as environmental monitoring, militar sensor networks, healthcare applications, networks for detecting chemical, biological, or radio logical materials, manufacturing automation, etc.

In the field of environmental monitoring, CO₂ measurement becomes an important issue related to the detection and prevention of forest fire and the control of fuzzy greenhouse emissions. In the case of fire detection, an early measurement of anomalous CO₂ concentration by a sensor network will help the extinction teams to locate fast and precisely the fire; for greenhouse emissions control, the monitoring system will allow a fast CO₂ emission detection, thus allowing a fast reaction to reduce its effects. However, the high energy requirements of most gas sensors in the market make difficult their use in portable battery-operated applications where energy autonomy is a must, as in wireless Sensor networks (WSN). An option is the use of non-dispersive infrared (NDIR) sensors, which present relative low power consumption at a reasonable accuracy value [2-3].

The goal of the present work is the study of the viability to integrate these sensors in battery operated low form-

factor wireless sensor networks nodes. Thus, this paper presents the design and test of a conditioning system able to transform the output voltage from CO₂ NDIR sensors into a more suitable signal which facilitates the calculation of the carbon dioxide concentration with a low-cost microcontroller.

The paper is organized as follows. In section II, the characteristics of the selected sensors are reviewed. Section III describes the designed sensor interface, detailing the operation of its main building blocks. Section IV explains the experimental tests performed and summarizes the main results achieved. Conclusions are drawn in Section V

NDIR Sensors: NDIR sensors operation is based on the absorption of infrared light due to the presence of the gas to be detected. Depending on the gas concentration, the light intensity arriving to a sensor photo detector changes, thus giving information the presence and concentration of the gas.

These devices are characterized by its relative low power consumption compared to conventional gas sensors and the possibility to be biased at low voltage ranges. That is why this non - dispersive infrared method



Fig. 1: IRC-A1 Carbon Dioxide Infrared sensor

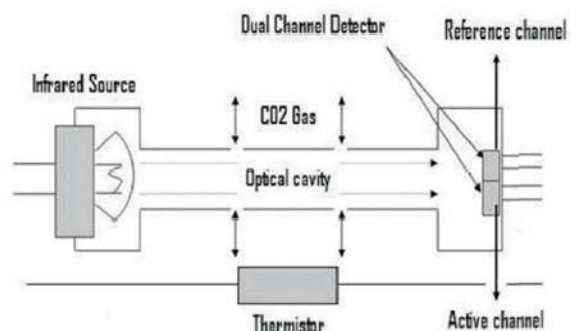

Fig. 2: Structure of an NDIR-based CO₂ sensor

is increasingly being used to measure CO₂ concentration [4]. In particular, in this work, the NDIR-based CO₂ sensors used are IRC-A from Alpha sense (Fig. 1).

In general and also for the selected one, NDIR CO₂ sensors consist of an infrared source with a determined frequency, an optical cavity where the gas to be detected can be diffused, a dual channel detector and an internal thermistor [5]. While a detector channel is used to measure the incident light (Related to the presence of CO₂), the other channel is used as a reference [6], compensating undesired effects. In the active channel, light is filtered such that only the wavelength that corresponds to an absorption band of the target gas is allowed to pass through. If the target gas is present in the optical cavity, the intensity of light which passes through the filter and hits the active channel detector decreases. In the reference channel, a filter only allows light wavelengths that are out of the absorption spectrum of the gas.

The use of a reference channel allows compensate variations in the light intensity due to other effects than gas sensing. In addition, NDIR detectors are highly sensitive to the ambient temperature, making necessary to constantly monitor the temperature to compensate the associated output drift. The internal thermistor is used for this purpose. Fig. 2 describes the structure of an NDIR-based CO₂ sensor.

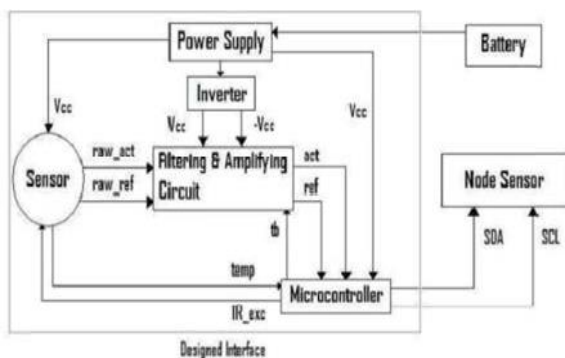

Fig. 3: Block diagram of the designed sensor interface

Due to the sensitivity of the sensor it is necessary to calibrate the device before starting to get measures. In the calibration process, firstly, the sensor has to be in a zero gas atmosphere to obtain the signal values of both active and reference channels. For the calibration process, the sensor takes a warm up time between 10 to 30 minutes. Next, a determined gas concentration has to be fixed at a known temperature. Once the channel values are measured, the sensor is ready to be used for gas concentration measurements, applying the obtained calibration data. Although some warm-up time is needed for calibration, the sensor does not need additional warm-up time in the measurement process, which allow us to leave the electronics interface in sleep mode until the gas concentration would be measured, saving power and battery operating life.

Sensor Interface: The interface circuit transforms the small and noisy signals provided by the sensor to more suitable signals to be properly read by an analog to digital converter, giving the best resolution. Once the values are read, they are

sent through a serial communication protocol to the node sensor.

Hardware Design: The block diagram of the designed sensor interface is shown in Fig. 3. It can be divided in three parts: the power supply, the filtering and amplification system and the interface control software [7].

Power Supply: Due to the requirements of low power consumption in battery operated sensor nodes, the proposed interface has been designed be powered with a 3V battery. The sensor output is given a symmetrical signal, so it is necessary to use a DC voltage inverter to provide the suitable negative level to the filtering and amplification electronics in the following conditioning stage. The negative voltage level is achieved using a TPS60403 charge pump voltage inverter from Texas Instruments. The NDIR excitation signal is provided by the microcontroller (line IR_exc in Fig. 3) included in the interface and consists of a square wave with a frequency of 2.5 Hz and 50% of duty cycle.

A power supply provides a constant output regardless of voltage variations. "Fixed" three-terminal linear regulators are commonly available to generate fixed voltages of plus 3 V and plus minus 5 V, 9 V, 12 V, or 15 V when the load is less than about 7 amperes.

The "78xx" series (7805, 7812, etc.) regulate positive voltages while the "79xx" series (7905, 7912, etc.) regulate negative voltages. Often, the last two digits of the device number are the output voltage; eg, a 7805 is a +5 V regulator, while a 7915 is a -15 V regulator. The 78xx series ICs can supply up to 1.5 Amperes depending on the model.

Features:

- Output Current up to 1A
- Output Voltages of 5, 6, 8, 9, 10, 12, 15, 18, 241.
- Thermal Overload Protection
- Short Circuit Protection
- Output Transistor Safe Operating Area Protection

This circuit is a small +5V power supply, which is useful when experimenting with digital electronics. Small inexpensive wall transformers with variable output voltage are available from any electronics shop and supermarket. Those transformers are easily available, but usually their voltage regulation is very poor, which makes then not very usable for digital circuit experimenter unless a better regulation can be achieved in some way [8-11]. The following circuit is the answer to the problem. This circuit can give +5V output at about 150 mA current, but it can be increased to 1 A when good cooling is added to 7805 regulator chip. The circuit has over overload and thermal protection.

When you have requirement for a project of say 12V, or even 5V if it's a digital project, then these are the types you use. 7805 or 7812 are the types. There are of course negative voltage regulators with the numbers 79XX which are substantially the same as those discussed here excepting they are negative. We will not consider them further. Assume your project calls for a basic fixed 12V DC. to operate. Looking back to our earlier tutorial we apply we apply all the same principles. Look at the original schematic.

In a typical linear power supply, AC line voltage is first down-converted to a smaller peak voltage using a transformer which is then rectified using a full wave bridge rectifier circuit. A capacitor filter is then used to smoothen the obtained sinusoidal signal. The residual periodic variation or ripple in this filtered signal is eliminated using an active regulator.

To obtain a DC power supply with both positive and negative output voltages, a center-tapped transformer is used, where a third wire is attached to the middle of the secondary winding and it is taken as the common ground point. Then voltages from the opposite ends of the winding will be positive or negative with respect to this point.

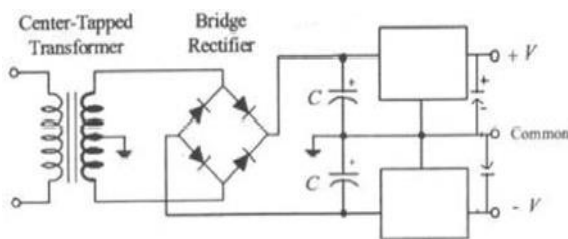

This circuit is a small +5V power supply, which is useful when experimenting with digital electronics. Small inexpensive wall transformers with variable output voltage are available from any electronics shop and supermarket. Those transformers are easily available, but usually their voltage regulation is very poor, which makes them not very usable for digital circuit experimenter unless a better regulation can be achieved in some way [8-11]. The following circuit is the answer to the problem. This circuit can give +5V output at about 150 mA current, but it can be increased to 1 A when good cooling is added to 7805 regulator chip. The circuit has over overload and thermal protection.

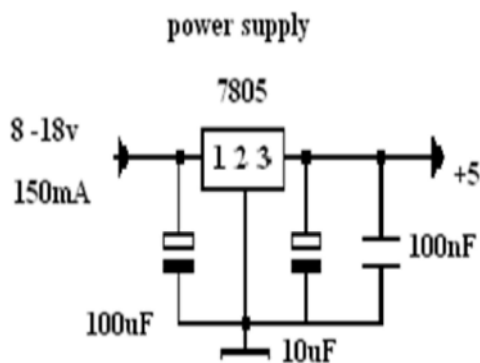

Filtering and Amplifying Circuit: A circuit for filtering and amplifying the raw signals from the sensor is implemented by using low-power operational amplifiers. The DC offset voltage previously filtered using a simple RC circuit.

Once the signals are properly filtered and the DC offset voltage is eliminated, they are amplified to be more suitable for being measured by the microcontroller. Two identical circuits are used for both active and reference operational amplifiers are used; however, in the last stage

the data signals have larger amplitudes, making necessary the use of rail-to-rail operational amplifiers. Figs. 4 and 5 show the data signal before and after the conditioning stage, respectively. The conditioned output signals present both positive and negative values, which is not compatible with the characteristics of the ADCs included in typical low-power microcontrollers.

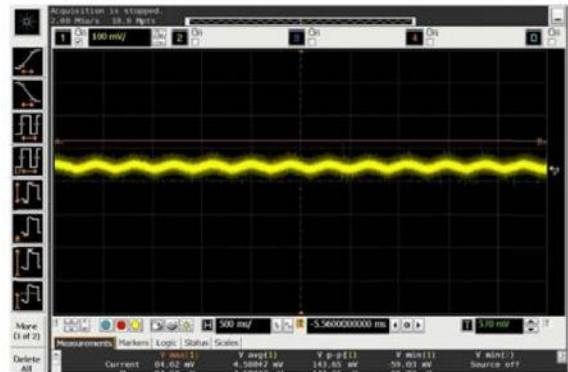

Fig. 4: AC component of raw active signal

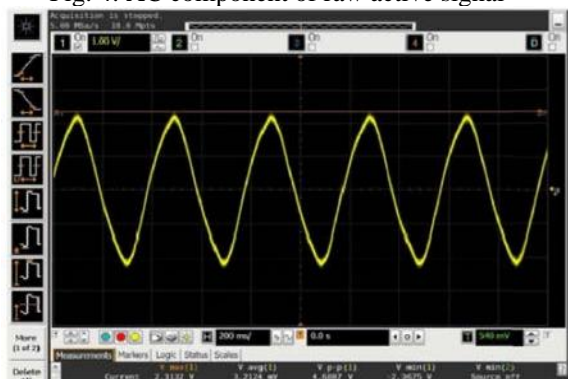

Fig. 5: Active signal after filtering and amplification

Thus, in order to allow an accurate reading of the sensor information, a voltage peak detector consisting of a capacitor stores the maximum positive value of the sensor signals at the output of the conditioning stage. Lines act and ref connects these peak detectors to the microcontroller ADC inputs, thus properly converting the voltage values to digital format. These peak detectors are periodically reset by the microcontroller using the tab line.

Thermistor: Due to the high sensitivity of the sensor to the ambient temperature it is needed to constantly monitor the temperature.

For this purpose a thermistor is included in the NDIR sensor device. The thermistor is a NTC resistor with a R3 k2 at 25°C and forms a resistive divider with a n additional resistor: NTC is connected internally to ground while a second resistor (R = 3 k) connects the NT Va. The voltage between the resistors is connected to an ADC input in the microcontroller (temp line, Fig. 3).

Microcontroller: Circumstances that we find ourselves in today in the field of microcontrollers had their beginnings in the development of technology of integrated circuits.

This development has made it possible to store hundreds of thousands of transistors into one chip. That was a prerequisite for production of microprocessors and the first computers were made by adding external peripherals such as memory, input-output lines, timers and other. Further increasing of the volume of the package resulted in creation of integrated circuits. These integrated circuits contained both processor and peripherals. That is how the first chip containing a microcomputer, or what would later be known as a microcontroller came about.

Memory is part of the microcontroller whose function is to store data. For a certain input we get the contents of a certain addressed memory location and that's all. Two new concepts are brought to us: addressing and memory location. Memory consists of all memory locations and addressing is nothing but selecting one of them. This means that we need to select the desired memory location on one hand and on the other hand we need to wait for the contents of that location. Besides reading from a memory location, memory must also provide for writing onto it. This is done by supplying an additional line called control line. We will designate this line as R/W (read/write). Control line is used in the following way; if $r/w=1$, reading is done and if opposite is true then writing is done on the memory location.

Let add 3 more memory locations to a specific block that will have a built in capability to multiply, divide, subtract and move its contents from one memory location onto another. The part we just added in is called "central processing unit" (CPU). Its memory locations are called registers.

Registers are therefore memory locations whose role is to help with performing various mathematical operations or any other operations with data wherever data can be found. Look at the current situation. We have two independent entities (memory and CPU) which are interconnected and thus any exchange of data is hindered, as well as its functionality.

Bus: That "way" is called "bus". Physically, it represents a group of 8, 16, or more wires. There are two types of buses: address and data bus. The first one consists of as many lines as the amount of memory we wish to address and the other one is as wide as data, in our case 8 bits or the connection line. First one serves to transmit address from CPU memory and the second to connect all blocks inside the microcontroller.

Input-Output Unit: Those locations we've just added are called "ports". There are several types of ports: input, output or bidirectional ports. When working with ports, first of all it is necessary to choose which port we need to work with and then to send data to, or take it from the port. When working with it the port acts like a memory location. Something is simply being written into or read from it and it could be noticed on the pins of the microcontroller.

Serial Communication: As we have separate lines for receiving and sending, it is possible to receive and send data (info.) at the same time. So called full-duplex mode block which enables this way of communication is called a serial communication block. Unlike the parallel transmission, data moves here bit by bit, or in a series of bits what defines the term serial communication comes from. After the reception of data we need to read it from the receiving location and store it in

memory as opposed to sending where the process is reversed. In order for this to work, we need to set the rules of exchange of data. These rules are called protocol. Data goes from memory through the bus to the sending location and then to the receiving unit according to the protocol.

Timer Unit: The timer block this can give information about time, duration, protocol etc. The basic unit of the timer is a free-run counter which is in fact a register whose numeric value increments by one in even intervals, so that by taking its value during periods T1 and T2 and on the basis of their difference we can determine how much time has elapsed. This is a very important part of the microcontroller whose understanding requires most of our time.

Watchdog: One more thing is requiring our attention is a flawless functioning of the microcontroller during its run-time.

Suppose that as a result of some interference (which often does occur in industry) our microcontroller stops executing the program, or worse, it starts working incorrectly. Of course, when this happens with a computer, we simply reset it and it will keep working. However, there is no reset button we can push on the microcontroller and thus solve our problem. To overcome this obstacle, we need to introduce one more block called watchdog.

This block is in fact another free-run counter where our program needs to write a zero in every time it executes correctly. In case that program gets "stuck", zero will not be written in and counter alone will reset the microcontroller upon achieving its maximum value. This will result in executing the program again and correctly this time around.

Implementation and Test: To verify the correct operation of the designed sensor interface a sealed tight crystal vessel has been used, controlling the inner carbon di oxide concentration by means of an Alicat Scientific flow meter, which allows selecting the suitable constant flow of CO₂ gas inside the receptacle. In this way, it is possible to control the exact amount of gas concentration by properly opening the valve during a determined time. Fig. 4 makes clear the need of pre-processing the raw signal provided by the sensor before to be read by the sensor node. This figure shows the AC component signal that must be amplified in order to calculate the gas concentration. In order to achieve the best sensitivity, the DC voltage offset in the sensor signal must be filtered before to be amplified. Results of the amplification and filtering of the sensor signal are shown in Fig. 5. sensor

2.CONCLUSION

This paper presents the development of a low power interface designed to measure CO₂ gas concentration levels for applications in battery operated wireless sensor networks.

Fig. 7 shows the actual prototype interface designed for that purpose. This device presents and average consumption of 25 mA in full operation and 2A in low power mode, at a bias voltage of 3 V. This consumption represents the 16.3% of the power consumption of a sensor no de, a very low value compared to standard gas sensor interfaces. Fig.8 compares the concentration readings of this interface and the real

concentration at different temperatures. According to the results obtained, the addition of the proposed sensing element to a wireless sensor node provides to the wireless network system an important feature in applications where precise CO₂ monitoring is necessary, as in forest fire detection or greenhouse emissions monitoring, with a minimum reduction

3. REFERENCES

- [1]. Ahmad, N., 2003. A Framework for Estimating Carbon Dioxide Emissions Embodied in International.
- [2]. Trade of goods. STI/SD/WAF(2003)20. Organisation for Economic Co-operation.
- [3]. Development (OECD). <http://www.oecd.org/sti/working-papers>.
- [4]. Ahmad, N. and A. W. Wyckoff, 2003. Carbon dioxide emissions embodied in international trade of
- [5]. goods. STI Working Paper 2003/15 (DSTI/DOC (2003) 15). Organisation for Economic Cooperation and Development (OECD), Paris, France. <http://www.oecd.org/sti/working-papers>.
- [6]. Ahmad, N., N. Yamano and OECD. 2006. The OECD's Input-Output Database: 2006 Edition, 29th.
- [7]. General Conference of The International Association for Research in Income and Wealth, Joensuu, Finland, 29th General Conference of The International Association for Research in Income and Wealth. http://www.oecd.org/document/3/0,2340,en_2649_33715_38071427_1_1_1_1,00.htm.
- [8]. Tatyana Aleksandrovna Skalozubova and Valentina Olegovna, 2013. Reshetova Leaves of Common Nettle (*Urtica dioica* L.) As a Source of Ascorbic Acid (Vitamin C), *World Applied Sciences Journal*, 28(2): 250-253.
- [9]. Rassoulinejad-Mousavi, S.M., 11M. Jamil and 2M. Layeghi, 2013. Experimental Study of a Combined Three Bucket H-Rotor with Savonius Wind Turbine, *World Applied Sciences Journal*, 28(2): 205-211.
- [10]. Vladimir G. Andronov, 2013. Approximation of Physical Models of Space Scanner Systems *World Applied Sciences Journal*, 28(4): 528-531.
- [11]. Ahmed, Naseer, 2013. Ultrasonically Assisted Turning: Effects on Surface Roughness *World Applied Sciences Journal*, 27(2): 201-206.