

Optimization of Microstrip Patch Antenna for Wireless Communication

R Rukmani¹

¹Research Scholar, School of Electrical and Electronics Engineering,
SASTRA Deemed University, Thanjavur, India
rukmanidullan@gmail.com

Abstract— This work aims to enhance the performance of a Microstrip Patch Antenna Array using the Particle Swarm Optimization (PSO) algorithm. These antennas are crucial components of modern wireless communication systems, particularly in the context of high-frequency applications like 5G. Designing these antennas to operate optimally is complex due to the various design parameters involved. This research employs the PSO algorithm in MATLAB to systematically refine the array antenna design. To optimize key performance metrics such as dimensions of antenna, gain, and bandwidth. This approach aims to create a highly efficient and customized antenna array. Consequently, this study offers insightful information on creating antennas with optimal performance for wireless communication systems.

Index Terms— PSO, Gain, optimization, CST, Antenna Parameters, MATLAB.

I INTRODUCTION

In recent years, seamless integration into devices has been made possible by the evolution of antennas in contemporary communication from massive to compact designs like microstrip patch antennas [1]. This progression highlights how important a role they play in balancing size and performance for wireless communication. Due to their adjustable emission patterns and adaptability, they also play important roles in radar, remote sensing, and IoT applications [2],[3]. When designing antennas, especially microstrip patch antennas, optimization techniques like Particle Swarm Optimization (PSO) are crucial. The performance of manual designs might not be at their best and can be time-consuming[4]. Optimization strategies are essential for obtaining higher antenna performance and adaptability since the need for efficient and miniaturized antennas in contemporary communication systems keeps on rising. For instance, Particle Swarm Optimization (PSO) provides logical approaches to maximize desirable features, balance design complexity, and optimize antennas[5]. To achieve greater performance and flexibility in antenna design, optimization methodologies become more essential due to the rising need for effective, tiny antennas in a variety of applications. Recently, there has been a surge in research focused on applying particle swarm optimization in the area of antenna design. [6] – [9]. Kennedy and Eberhart created Particle Swarm Optimisation (PSO) in 1995 [10], which is a flexible optimization algorithm influenced by social behavior, particularly bird swarming. It adjusts particle velocities depending on their closeness to the best-found solutions within a swarm, providing a simple yet effective method for optimizing nonlinear equations. PSO is a powerful tool in a variety of applications, including neural

network training, due to its simplicity, ease of implementation, and ability to handle computationally costly or non-differentiable objective functions. PSO has proven that it is beneficial in the area of antenna design by optimizing parameters such as dimensions, locations, and shapes to meet desired features of an antenna's performance, including return loss, bandwidth, and radiation pattern[11],[12]. The electromagnetic community has widely adopted PSO for antenna design, resulting in significant increases in antenna performance across a wide range of applications. The study seeks to show the beneficial effects of the Particle Swarm Optimization (PSO) technique to optimize microstrip patch antennas, to improve characteristics such as bandwidth, gain, and dimensions of the antenna. Overall, it contributes to the understanding of how optimization strategies might increase the performance of microstrip patch antennas, which are critical components of current communication systems.

II PARTICLE SWARM OPTIMIZATION ALGORITHM

The Particle Swarm Optimization (PSO) is an optimization technique based on the collective behavior of animals such as birds and fish. In PSO, a population of potential solutions, represented as particles, flows around a search space to discover the optimal solution to a difficult issue. Each particle has a position and a velocity, which determine its present solution and travel direction. The method iteratively adjusts the placements and velocities of these particles based on their unique experiences (personal best) and the best solution obtained by any particle in the swarm (global best). PSO effectively searches the search space, achieving a balance between exploration and exploitation to settle on optimum or near-optimal solutions. It has several applications in handling complex optimization and search problems across a variety of disciplines[10],[13].

A. Parameterized Antenna Model

Define The Particle Swarm Optimization (PSO) algorithm was implemented to optimize the design of an array antenna. The objective is to find the optimal values for various design parameters such as number of patches, patch size, position, and feed that maximize the antenna's fitness function. The system begins with the creation of a parameterized antenna model that captures the essential structural and geometric aspects of the antenna array. Design parameters, including several radiating patches, and feed point positions and orientations, are defined within this model. The problem formulation for the provided PSO-based antenna optimization code involves maximizing the performance of a microstrip patch antenna. This optimization aims to find the best configuration of design parameters, including the number of patches, patch size, position, and feed points, denoted as "x."

The performance of the antenna is quantified by a fitness function, "F(x)," which combines aspects such as antenna gain, bandwidth, and radiation pattern. The objective is to find the values of "x" that maximize "F(x)." The Particle Swarm Optimization (PSO) algorithm is employed to systematically explore the design parameter space, iteratively adjusting "x" to converge toward the optimal or near-optimal antenna configuration that maximizes performance.

B. Steps involved in PSO:

i) Initialization of PSO Parameters:

The algorithm is initialized by setting up the parameters for the Particle Swarm Optimization (PSO) algorithm. These parameters include the number of particles in the swarm, the maximum number of iterations, the number of design variables, and the range or limits for each design variable. These parameters define how the PSO algorithm will operate.

ii) Initializing the particle position and particle velocity

Initially, particle velocities and particle positions are initialized for each particle in the swarm. These initial positions represent potential solutions to the optimization problem, while how particles proceed across the search space is governed by their beginning velocities. Variables that monitor the best position and fitness for each particle, as well as the global best position and fitness for the whole swarm, are initialized to starting values.

iii) Evaluate Fitness function:

A fitness function is formulated to evaluate the performance of each antenna array configuration. The fitness function quantifies the antenna's ability to meet the desired specifications, considering the output parameters of VSWR, directivity, power gain, insertion loss, return loss, and center frequency. The fitness function takes the design parameter values as input and returns a fitness value. The goal is to maximize this fitness value because higher fitness indicates better antenna performance.

iv) Update Particle Velocities and Positions:

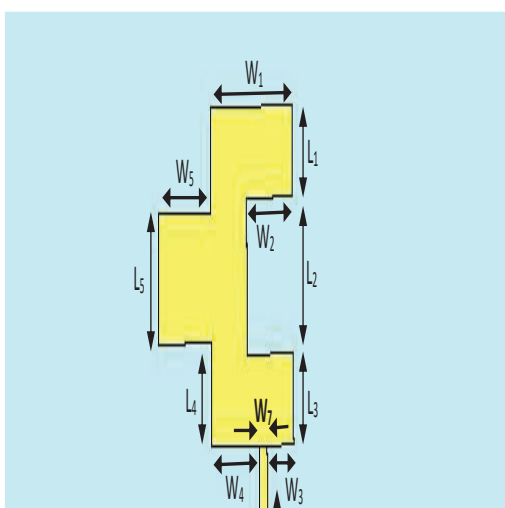

Figure 1 Structure of single patch

After initializing the particles, the algorithm proceeds with the PSO iterations on each iteration, particles update their

velocities and positions based on mathematical formulas that consider their own experiences, the best experiences of their neighbors (personal best), and the best experience of the entire swarm (global best). These updates aim to guide the particles toward better solutions in the search space. Particle positions are also constrained to stay within the specified variable ranges. The fitness of each particle is evaluated after the position update, and if a particle achieves better fitness, its best position and fitness are updated. The global best position and fitness are also updated if a better solution is found in the swarm. The velocity and position updates are governed by the following equations:

$$v_i(t + 1) = w * v_i(t) + c1 * rand() * (pbest_i - x_i(t)) + c2 * rand() * (gbest - x_i(t)) \quad (1)$$

Position updates:

$$[x_i(t + 1) = x_i(t) + v_i(t + 1)] \quad (2)$$

v) Extract the Optimized Parameters

After completing the specified number of iterations, the code displays the optimized results. This includes the optimal values for the design parameters (e.g., number of patches, patch size, position, and feed) that maximize the antenna's performance, as well as the best fitness value achieved during the PSO optimization process. These results provide insight into the design configuration that yields the best antenna performance according to the defined fitness function.

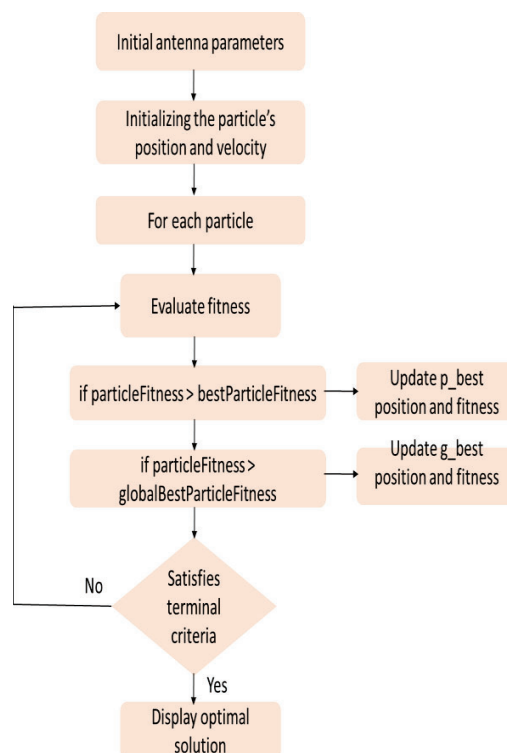

Figure 2 Flowchart of PSO

| Parameter | Value (mm) | Parameter | Value (mm) |
|----------------|------------|----------------|------------|
| a | 20.0 | Z ₄ | 1.4 |
| b | 8.0 | Z ₅ | 0.27 |
| Z ₁ | 4.56 | Z ₆ | 0.2 |
| Z ₂ | 1.10 | Z ₇ | 0.1 |
| Z ₃ | 90 | Z ₈ | 1.6 |
| Z ₄ | 1.4 | G | 1.9 |

III

DESIGN OF MICROSTRIP PATCH ANTENNA ARRAY

In this section, we present the detailed design considerations and parameters of the microstrip patch antenna tailored for the 35 to 37 GHz frequency band. The antenna design process involves careful optimization of substrate material, microstrip patch geometry, and feeding techniques to achieve desired performance characteristics. The design of a microstrip antenna at a frequency range of 35 to 37 GHz was done by using the CST Studio suite (Learning edition) and the design of the antenna was inspired by the optimization result obtained from the particle swarm optimization algorithm. The choice of substrate material profoundly influences the antenna's overall performance. In this study, the Rogers RT/duroid 5880 substrate was due to its favorable dielectric constant ($\epsilon_r \approx 2.2$) and low-loss tangent ($\tan \delta \approx 0.0009$) at the target frequency range. This substrate material offers excellent impedance matching and radiation efficiency, contributing to enhanced overall antenna performance [14]. Using transmission line theory the dimensions of the antenna were estimated for this work [1],[15], [16]. The dimensions of a single patch are shown in Table 1 and the structure is depicted in Figure 2. Table 1: List of the physical dimensions of a single patch. Array antennas are designed to enhance directivity and gain by arranging multiple antenna elements in specific patterns. They focus on creating controlled radiation patterns and are used in applications requiring targeted coverage, like radar systems and point-to-point links [17]. The structure of the array antenna is shown in Figure 2 and the dimension of the array antenna is illustrated in Table 2.

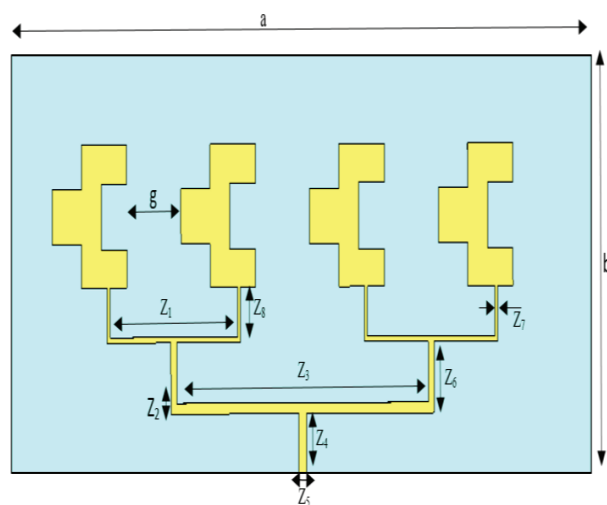

Figure 3 Antenna structure for a 1x4 array

Table 2: Measurements of the proposed antenna array

A corporate feed technique for array antennas involves creating an efficient distribution network for RF signals to multiple antenna elements. This technique is essential for optimizing signal reception and transmission at the challenging millimeter-wave frequency range of 35 to 37 GHz. Key considerations include antenna layout, impedance matching, precise beamforming, low-loss materials, and isolation to minimize interference. A well-designed corporate feed system enhances gain, improves beamforming, and boosts capacity, making it suitable for high-data-rate applications [3], [19], [20]. In this approach, a corporate feed network is employed to split power into $2n$ parts (where n can be 2, 4, 8, 16, etc.). This splitting is achieved using either tapered transmission lines or quarter-wavelength impedance transformers [19]. The patch elements are connected using the quarter-wavelength impedance transformer technique. [21], [22]. To avoid mutual coupling among each antenna element, the spacing between each antenna element kept up at 1.9mm, which is the 0.25λ distance. To attain the same phase, the length of the transmission line of each adjacent element is kept equal. The width of the feed line for multiple elements of an array to obtain the desired matching impedance is calculated by [21]

$$w_{zc} = \left(\frac{377}{Z_c \sqrt{\epsilon_r}} - 2 \right) \times h_s$$

Where ,

w_{zc} is the feed line's width,

Z_c is its matching impedance,

ϵ_r is the symbol of the dielectric constant of the substrate,

Thickness is given by the notation h .

The 4-element array antenna is compact, with dimensions of 8mm x 20mm, and the patch conductor and ground plane are made of copper.

Various tactics have been presented by numerous research. One of the simple methods to increase the gain of the microstrip antenna is to build an array out of various individual components [18].

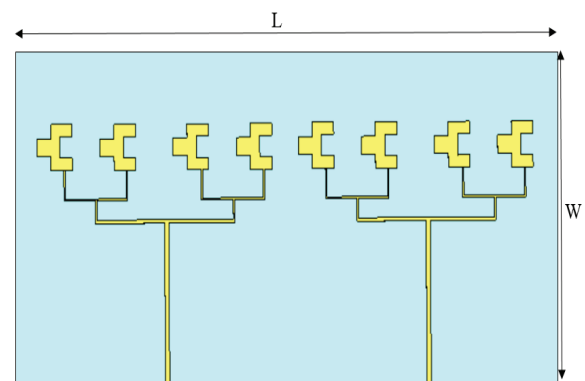

Figure 4 1x8 antenna array

Numerous research have suggested several methods to increase the gain of array antennas. The symmetry of an array is maintained in the suggested 1x8 array layout, and no additional modifications are made. $L = 20$ mm and $W = 40$ mm are the total substrate measurements in this arrangement.

IV RESULTS AND DISCUSSION

a) Reflection Coefficient:

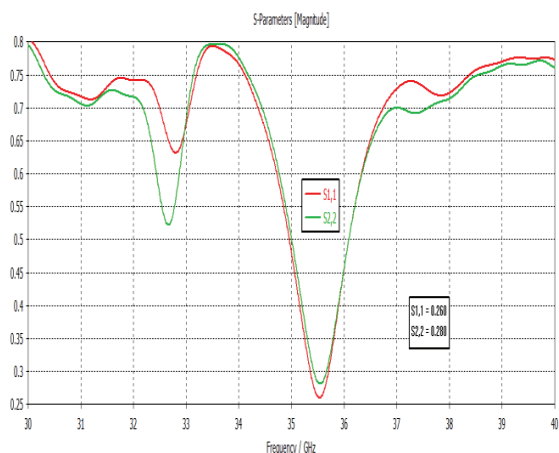

Figure 5 Reflection Coefficient for 1x8 array

The antenna resonances for port 1 are at a magnitude of -11.69 dB, with a center frequency of 35.4 GHz and a bandwidth of 34.95 to 36.102 GHz. The antenna resonates with a center frequency of 34.95 GHz, a reflection co-efficient magnitude of -11.02 dB, and a bandwidth between 34.96 and 36.14 GHz, as well as for port-2.

b) VSWR

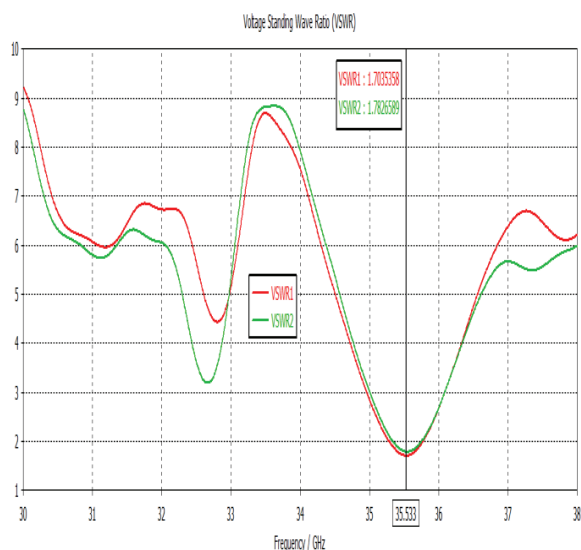

Figure 6 VSWR for 1x8 array

The Voltage Standing Wave Ratio (VSWR) measurements for Ports 1 and 2 of an antenna, at 35.533 GHz, Port 1 exhibits a VSWR of 1.704, while Port 2 shows a VSWR of 1.783. These VSWR values are relatively close to the ideal value of 1.0, indicating keen impedance matching and effective power transmission for both ports at 35.53 GHz. The low VSWR values are desirable for minimizing signal loss, particularly in high-frequency applications, so further impedance tuning or

matching may be required to optimize the antenna's performance.

c) Gain

The graph depicting the gain of the array antenna provides valuable insights into its performance. Gain, measured in decibels (dB), signifies the antenna's capability to concentrate and direct the transmitted signal in a specific direction. In this case, the graph illustrates an impressive peak gain of 9.805 dB, almost reaching 10 dB, at the frequency of 35 GHz. This substantial gain level shows that the antenna can effectively concentrate and amplify the signal, making it particularly well-suited for wireless communication applications. The antenna's efficacy in long-distance and high-frequency communication scenarios is increased by the antenna's substantial gain value, which denotes that it can transmit and receive signals with more strength and directionality. This attribute is particularly valuable in wireless communication systems where signal strength and precision are critical for reliable and efficient data transfer.

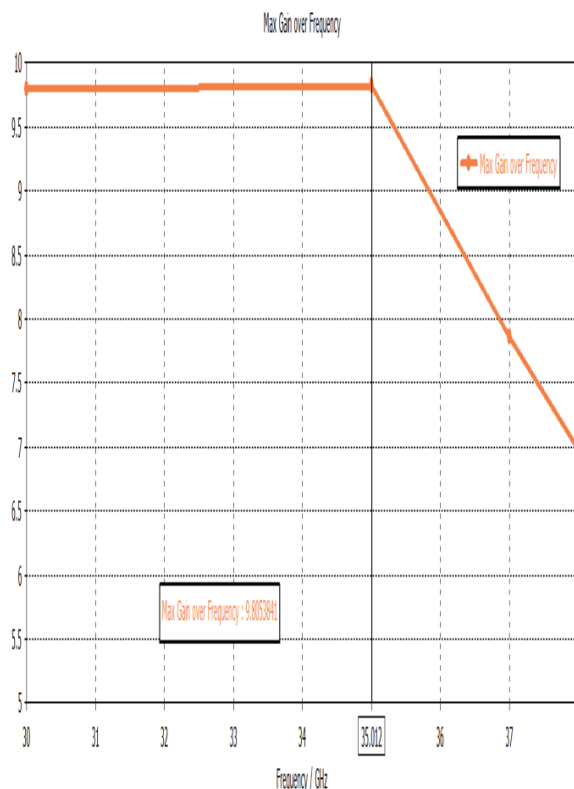

Figure 7 Gain for 1x8 array

d) Farfield Directivity

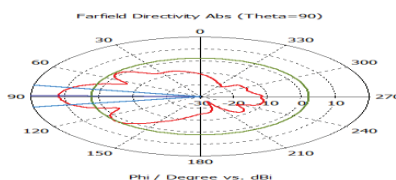

Figure 8 Farfield directivity for Port 1

PORT 1: Figure 8 displays the antenna's Farfield directivity pattern for Port 1 and offers crucial details about its radiation properties. First, the pattern shows that the main beam, which

corresponds to the major radiation direction, is pointed at 89 degrees. This signifies that the antenna's emitted or received signals are mostly focused in this direction. The transmission of the signal has been optimized by intentionally selecting this orientation to line up with the intended target or receiver. Second, the measured side lobe level of -9.4 dB indicates that radiation in directions other than the main lobe, albeit weaker than the main beam, is nonetheless substantial. Although the side lobes' negative dB value shows that they are significantly less intense than the main lobe, it is important to emphasize that they are not at all feeble.

PORT 2:

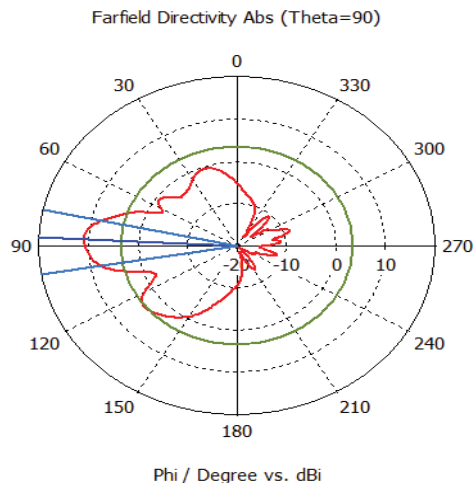

Figure 9 Farfield directivity for Port 1

The primary radiation beam of the antenna, which is aimed at 87 degrees according to the Farfield directivity pattern for Port 2 of the antenna, indicates concentrated directional transmission. The lowered side lobe levels at -7.3 dB show how successfully the antenna suppresses radiation in other directions, hence reducing interference. The antenna's high gain of 10.8 dBi in the main lobe direction makes it perfect for uses needing powerful and accurate signal transmission or reception in that particular orientation, which is advantageous to many communication and wireless systems.

V CONCLUSION

The primary objective of the research is to use the Particle Swarm Optimisation (PSO) approach to optimize Patch Antenna Arrays for high-frequency wireless communications for the specified issue. Microstrip Patch Antenna (MPA) based on PSO has been developed, simulated, and optimized for the defined issue to methodically improve the size, gain, and antenna array bandwidth, allowing for the development of highly effective, specialized arrays by systematically refining the antenna array design parameters, such as the number of patches, patch size, position, and feed. The findings of this research not only emphasize the critical role that optimization plays in contemporary antenna design but also provide valuable guidance for designing efficient antennas that are specifically suited to the requirements of wireless communication systems. Furthermore, it suggests potential areas for further refinement and optimization, such as addressing the challenges in identifying the optimal combination of position and feed, and highlights the importance of incorporating real-world data and

multi-stage optimization procedures for even more robust antenna designs in the future.

REFERENCES

- [1] N. A. Wahab, S. A. Nordin, W. N. W. Muhamad, and S. S. Sarmin, "Microstrip Rectangular Inset-Fed Patch Array Antenna for WiMax Application," in 2020 IEEE International RF and Microwave Conference (RFM), Kuala Lumpur, Malaysia: IEEE, Dec. 2020, pp. 1–4. doi: 10.1109/RFM50841.2020.9344799.
- [2] N. Ojaroudiparchin, Ming Shen, and G. F. Pedersen, "Beam-steerable microstrip-fed bow-tie antenna array for fifth generation cellular communications," in 2016 10th European Conference on Antennas and Propagation (EuCAP), Davos, Switzerland: IEEE, Apr. 2016, pp. 1–5. doi: 10.1109/EuCAP.2016.7481156.
- [3] P. Subbulakshmi and R. Rajkumar, "Design and characterization of corporate feed rectangular microstrip patch array antenna," in 2013 IEEE International Conference ON Emerging Trends in Computing, Communication and Nanotechnology (ICECCN), Tirunelveli: IEEE, Mar. 2013, pp. 547–552. doi: 10.1109/ICE-CCN.2013.6528560.
- [4] Y. K. Choukiker, S. K. Behera, B. K. Pandey, and R. Jyoti, "Optimization of Planar Antenna for ISM Band Using Particle Swarm Optimization Technique," 2011.
- [5] R. Nagpal, P. Singh, and B. P. Garg, "Smart Particle Swarm Optimization," in 2021 International Conference on Computing, Communication, and Intelligent Systems (ICCCIS), Greater Noida, India: IEEE, Feb. 2021, pp. 167–173. doi: 10.1109/ICCCIS51004.2021.9397141.
- [6] R. N. Biswas and A. Kar, "A novel PSO-IE3D based design and optimization of a low profile Dual Slot Microstrip Patch Antenna," in TENCON 2008 - 2008 IEEE Region 10 Conference, Hyderabad, India: IEEE, Nov. 2008, pp. 1–4. doi: 10.1109/TENCON.2008.4766781.
- [7] P. Elechi, S. Orike, and C. E. Ikpo, "Performance Analysis of Patch Antenna for Ultra-Wideband using Particle Swarm Optimization," vol. 13, no. 3.
- [8] K. V. Rop, D. B. O. Konditi, H. A. Ouma, and S. M. Musyoki, "PARAMETER OPTIMIZATION IN DESIGN OF A RECTANGULAR MICROSTRIP PATCH ANTENNA USING ADAPTIVE NEURO-FUZZY INFERENCE SYSTEM TECHNIQUE," vol. 4, no. 3, 2012.
- [9] F. A. Ali and K. T. Selvan, "A study of PSO and its variants in respect of microstrip antenna feed point optimization," in 2009 Asia Pacific Microwave Conference, Singapore: IEEE, Dec. 2009, pp. 1817–1820. doi: 10.1109/APMC.2009.5384147.
- [10] J. Kennedy and R. Eberhart, "Particle Swarm Optimization," Proc. ICNN'95 - Int. Conf. Neural Netw. 1995, vol. 4, pp. 1948–1953. doi: 10.1109/ICNN.1995.488968.
- [11] J. Robinson and Y. Rahmat-Samii, "Particle swarm optimization in electromagnetics," IEEE Trans. Antennas Propag., vol. 52, no. 2, pp. 397–407, Feb. 2004. doi: 10.1109/TAP.2004.823969.
- [12] N. Jin and Y. Rahmat-Samii, "Advances in Particle Swarm Optimization for Antenna Designs: Real-Number, Binary, Single-Objective and Multiobjective Implementations," IEEE Trans. Antennas Propag., vol. 55, no. 3, pp. 556–567, Mar. 2007. doi: 10.1109/TAP.2007.891552.
- [13] Eberhart and Yuhui Shi, "Particle swarm optimization: developments, applications, and resources," in Proceedings of the 2001 Congress on Evolutionary Computation (IEEE Cat. No.01TH8546), Seoul, South Korea: IEEE, 2001, pp. 81–86. doi: 10.1109/CEC.2001.934374.
- [14] S. Singh, A. Kumar Singh, Karunesh, A. Pandey, and R. Singh, "A Novel MIMO Microstrip Patch Antenna for 5G Applications," in 2021 International Conference on Computing, Communication, and Intelligent Systems (ICCCIS), Greater Noida, India: IEEE, Feb. 2021, pp. 828–833. doi: 10.1109/ICCCIS51004.2021.9397137.
- [15] L. Lu, G. Y. Li, A. L. Swindlehurst, A. Ashikhmin, and R. Zhang, "An Overview of Massive MIMO: Benefits and Challenges," IEEE J. Sel. Top. Signal Process., vol. 8, no. 5, pp. 742–758, Oct. 2014. doi: 10.1109/JSTSP.2014.2317671.
- [16] "PSO Based Microstrip Patch Antenna Design for ISM Band," in 2019 5th International Conference on Advanced Computing & Communication Systems (ICACCS), Coimbatore, India: IEEE, 2019.
- [17] E. Al Abbas, M. Ikram, A. T. Mobashsher, and A. Abbosh, "MIMO Antenna System for Multi-Band Millimeter-Wave 5G and Wideband 4G Mobile Communications," IEEE Access, vol. 7, pp. 181916–181923, 2019. doi: 10.1109/ACCESS.2019.2958897.

- [18] N. Shoaib, S. Shoaib, R. Y. Khattak, I. Shoaib, X. Chen, and A. Perwaiz, "MIMO Antennas for Smart 5G Devices," *IEEE Access*, vol. 6, pp. 77014–77021, 2018, doi: 10.1109/ACCESS.2018.2876763.
- [19] K. DurgaRao and K. N. Pillai, "Design Array Antenna Using Different Feeding Technique in HFSS," in *2020 International Conference for Emerging Technology (INCET)*, Belgaum, India: IEEE, Jun. 2020, pp. 1–4. doi: 10.1109/INCET49848.2020.9154127.
- [20] U. Ullah, M. Al-Hasan, S. Koziel, and I. B. Mabrouk, "Series-Slot-Fed Circularly Polarized Multiple-Input–Multiple-Output Antenna Array Enabling Circular Polarization Diversity for 5G 28 GHz Indoor Applications," *IEEE Trans. Antennas Propag.*, vol. 69, no. 9, pp. 5607–5616, Sep. 2021, doi: 10.1109/TAP.2021.3066247.
- [21] M. M. Kamal et al., "A Novel Hook-Shaped Antenna Operating at 28 GHz for Future 5G mmwave Applications," *Electronics*, vol. 10, no. 6, p. 673, Mar. 2021, doi: 10.3390/electronics10060673.
- [22] S. Imtiaj and S. Bhattacharya, "Performance Comparison Between 2×1 and 2×2 Corporate Feed Antenna Array in X-band," in *2020 IEEE Calcutta Conference (CALCON)*, Kolkata, India: IEEE, Feb. 2020, pp. 189–193. doi: 10.1109/CALCON49167.2020.9106492.