

A Compact 27 GHz Microstrip Patch Antenna for 5G Millimeter wave Communication

R.Abisha
PG Student
Department of Electronics and
Communication Engineering
Alagappa Chettiar Government
College of Engineering and
Technology
Karaikudi
abishareginald@gmail.com

P.Aarthi
PG Student
Department of Electronics and
Communication Engineering
Alagappa Chettiar Government
College of Engineering and
Technology
Karaikudi
aarthipichairaj5991@gmail.com

Dr.D.Helena Margaret
Associate Professor
Department of Electronics and
Communication Engineering
Alagappa Chettiar Government
College of Engineering and
Technology
Karaikudi
helenamargaret@accet.ac.in

Abstract— Millimeter wave frequency bands have become a key enabling technology for fifth-generation (5G) wireless communication systems due to their ability to support high data rates and large bandwidth. Antenna structures operating in these frequency ranges must provide compact size, efficient radiation, and stable impedance characteristics. This work presents the analysis of a compact rectangular microstrip patch antenna operating at 27 GHz for potential 5G millimeter wave applications. The antenna structure is simulated on a Rogers RT/Duroid 5880 substrate with a dielectric constant of 2.2 and a thickness of 0.787 mm. A microstrip line feeding technique is employed to excite the radiating patch while maintaining a compact overall substrate dimension of 6 mm × 6 mm. Electromagnetic simulation is performed using CST Studio Suite to evaluate the antenna characteristics. The obtained results demonstrate a return loss of -31 dB at the resonant frequency of 27 GHz and a voltage standing wave ratio of 1.057, indicating excellent impedance matching. An impedance bandwidth of 1.711 GHz is achieved between 26.251 GHz and 27.962 GHz. The antenna exhibits a gain of 7.64 dBi with stable radiation characteristics, suggesting suitability for compact 5G millimeter wave communication systems.

Keywords— Microstrip Patch Antenna, Millimeter Wave Antenna, 5G Communication, 27 GHz Band, Rogers RT/Duroid 5880, Antenna Simulation

I. INTRODUCTION

The rapid growth of wireless communication technologies has significantly increased the demand for higher data rates, lower latency, and improved spectral efficiency. Fifth-generation (5G) communication systems are designed to meet these requirements by enabling high capacity wireless connectivity for applications such as smart cities, autonomous vehicles, and Internet of Things (IoT) devices. One of the key technologies that enables these capabilities is the use of millimeter wave (mmWave) frequency bands, which provide wider

bandwidth and support multi gigabit data transmission [1]. Regulatory and standardization organizations such as the International Telecommunication Union and the 3rd Generation Partnership Project have identified several mmWave frequency bands above 24 GHz, including the 26 GHz and 28 GHz bands, for future 5G deployments [2].

Antennas operating in the millimeter wave spectrum must satisfy several important requirements such as compact size, high radiation efficiency, and reliable impedance matching. Among the various antenna structures, microstrip patch antennas have gained significant attention due to their low profile, lightweight configuration, ease of fabrication, and compatibility with integrated microwave circuits. These characteristics make microstrip antennas suitable for compact wireless communication devices and high frequency applications.

Several studies have investigated microstrip antennas designed for millimeter wave communication systems. A comprehensive overview of mmWave communication technologies was presented by Theodore S. Rappaport and colleagues, highlighting the potential of mmWave frequencies for achieving high capacity wireless networks [1]. In addition, various antenna designs operating near the 26 GHz and 28 GHz bands have been proposed to improve bandwidth and radiation performance [2]. Many of these designs employ techniques such as slot loading, stacked patches, or antenna arrays to enhance antenna characteristics.

Although these approaches can improve antenna performance, they often introduce additional design complexity and fabrication challenges. Complex antenna structures may also increase the overall size and cost of the system. In contrast, simple single patch microstrip antennas offer a compact and straightforward design while still providing

acceptable radiation performance for millimeter wave communication systems [3].

Another important factor affecting antenna performance is the choice of substrate material. At millimeter wave frequencies, dielectric losses and signal attenuation can significantly influence antenna efficiency. Substrate materials such as Rogers RT/Duroid 5880 are widely used in mmWave antenna designs because of their low dielectric constant and low loss tangent, which help improve radiation efficiency and reduce propagation losses [4].

Motivated by the need for compact and efficient antenna solutions for millimeter wave communication systems, this work investigates a rectangular microstrip patch antenna operating at 27 GHz. The antenna is simulated on a Rogers RT/Duroid 5880 substrate and excited using a microstrip line feeding technique. The antenna performance is analyzed through electromagnetic simulations using CST Studio Suite, and key parameters such as return loss, bandwidth, voltage standing wave ratio (VSWR), gain, and radiation characteristics are evaluated. The obtained results demonstrate that the proposed antenna provides stable impedance matching and suitable radiation performance for millimeter wave wireless communication applications.

II. ANTENNA DESIGN

The microstrip patch antenna investigated in this study is designed to operate at a resonant frequency of 27 GHz, which lies in the millimeter wave spectrum and is suitable for high frequency wireless communication systems. Millimeter wave frequencies are widely considered for next generation communication networks due to their ability to support high data rates and large bandwidth.

The antenna is simulated on a Rogers RT/Duroid 5880 substrate with a dielectric constant of 2.2 and a thickness of 0.787 mm. This substrate is commonly used in high-frequency antenna applications because of its low dielectric loss, stable electrical properties, and lightweight characteristics, which improve antenna efficiency and radiation performance.

The antenna structure consists of three primary layers: a radiating patch, a dielectric substrate, and a ground plane. The patch and ground plane are simulated using copper with a thickness of 0.0175 mm, while the dielectric substrate separates the conductive layers. This layered configuration is widely adopted in microstrip antenna structures due

to its compact geometry, low profile, and ease of fabrication.

The overall dimension of the antenna substrate is 6 mm × 6 mm, resulting in a compact configuration suitable for integration into millimeter wave devices. The rectangular patch is excited using a microstrip line feeding technique, in which the feed line is directly connected to the edge of the radiating patch. This feeding method is simple and provides effective impedance matching between the transmission line and the radiating element.

The antenna geometry was modeled and analyzed using CST Studio Suite, which enables accurate evaluation of electromagnetic behavior through full wave simulation. The design process began with theoretical calculations of the patch dimensions based on standard microstrip antenna equations [5]. These parameters were then refined through several simulation iterations to achieve resonance at the desired operating frequency.

A. Width of the Patch

The width of the rectangular patch significantly influences the radiation efficiency and bandwidth of the antenna. The approximate width of the patch can be calculated using

$$W_p = \frac{c}{2f_r} \sqrt{\frac{2}{\epsilon_r + 1}}$$

Where,

W_p = width of the patch

c = speed of light in free space (3×10^8 m/s)

f_r = resonant frequency

ϵ_r = dielectric constant of the substrate

B. Effective Dielectric Constant

Due to the presence of fringing fields around the edges of the patch, the effective dielectric constant must be considered. It can be calculated using

$$\epsilon_{eff} = \frac{\epsilon_r + 1}{2} + \frac{\epsilon_r - 1}{2} \left(1 + \frac{12h}{W_p}\right)^{-1/2}$$

where

h = substrate thickness

W_p = patch width

C. Effective Length of the Patch

The effective length corresponding to the resonant frequency is expressed as,

$$L_{eff} = \frac{c}{2f_r \sqrt{\epsilon_{eff}}}$$

D. Length Extension

Because of fringing fields, the electrical length of the patch appears slightly larger than its physical length. The extension in length can be estimated as,

$$\Delta L = 0.412h \frac{(\epsilon_{eff} + 0.3)(W_p/h + 0.264)}{(\epsilon_{eff} - 0.258)(W_p/h + 0.8)}$$

E. Actual Length of the Patch

The physical length of the patch is obtained by subtracting the fringing field extension from the effective length

$$L_p = L_{eff} - 2\Delta L$$

F. Ground Plane Dimensions

To minimize edge effects and ensure stable radiation characteristics, the ground plane dimensions are typically chosen larger than the patch dimensions. The approximate substrate dimensions can be expressed as

$$L_s = L_p + 6h$$

$$W_s = W_p + 6h$$

where

L_s = substrate length

W_s = substrate width

The geometric structure of the proposed antenna was modeled in CST Studio Suite, and the antenna layout used for simulation is illustrated in Fig. 1.

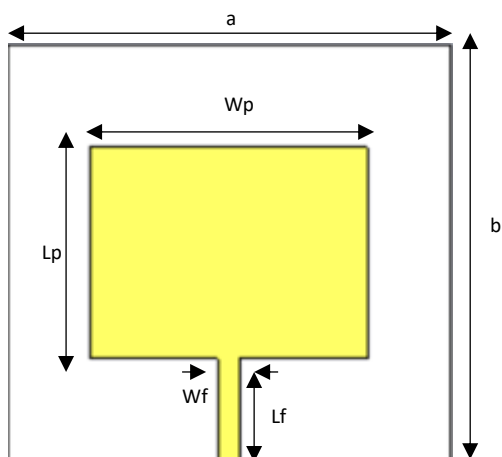

Fig. 1. Antenna top view

The optimized antenna dimensions used in the simulation are summarized in Table I.

Table I. Optimized Antenna Parameters

Parameter	Description	Value
W_p	Patch Width	3.74 mm
L_p	Patch Length	3.06 mm
W_f	Feed Line Width	0.30 mm
L_f	Feed Line Length	1.47 mm
W_s (a)	Substrate Width	6 mm
L_s (b)	Substrate Length	6 mm
h	Substrate Thickness	0.787 mm
t	Copper Thickness	0.0175 mm

The CST simulation model of the antenna is illustrated in Fig. 2.

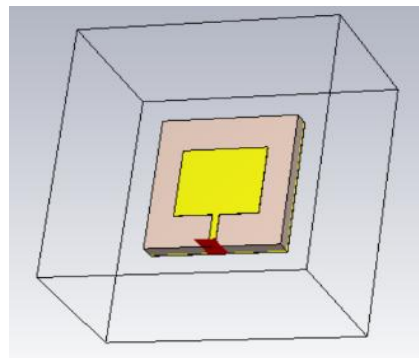

Fig. 2. CST view of the designed antenna

III. RESULTS AND PERFORMANCE ANALYSIS

The designed microstrip patch antenna was modeled and analyzed using the electromagnetic simulation environment provided by CST Studio Suite. The antenna structure consists of a rectangular radiating patch printed on a Rogers RT/Duroid 5880 substrate with a dielectric constant of 2.2 and thickness of 0.787 mm. A microstrip line feed is used to excite the patch, enabling effective impedance matching and stable signal excitation.

The antenna performance was evaluated in terms of several important parameters including S parameters, bandwidth, Voltage Standing Wave Ratio (VSWR), radiation pattern, gain, and directivity. These parameters are widely used to

assess the efficiency and radiation characteristics of antennas operating in the millimeter wave frequency range.

Simulation results indicate that the antenna resonates close to the target frequency of 27 GHz, demonstrating proper impedance matching and stable electromagnetic behaviour.

A. S-Parameters

The reflection coefficient (S11) is an important parameter that indicates how much power is reflected from the antenna input port. A lower S11 value indicates better impedance matching between the feed line and the antenna. The simulated results show a significant reduction in return loss near the operating frequency, confirming efficient power radiation.

The bandwidth of the antenna is determined from the frequency range where the return loss remains below -10 dB. The obtained bandwidth is 1.711 GHz which indicates that the antenna operates effectively within the desired millimeter wave frequency band.

The S parameter of the simulated antenna is shown in Fig.3.

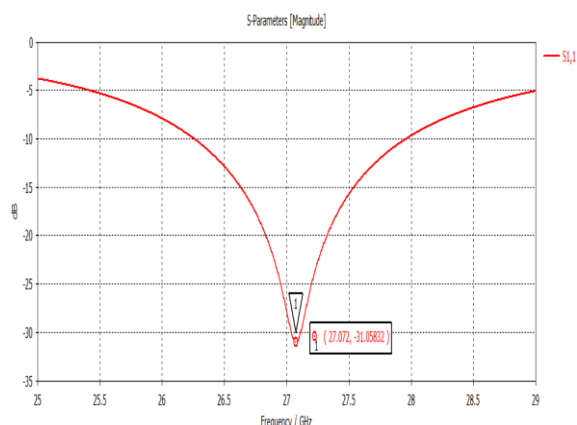

Fig. 3. Return Loss of the designed antenna at 27GHz

B. Voltage Standing Wave Ratio (VSWR)

The Voltage Standing Wave Ratio (VSWR) describes the level of impedance matching between the transmission line and the antenna. An ideal antenna typically has a VSWR close to 1. The simulated results show that the antenna maintains a VSWR value close to unity at the resonant frequency, indicating good impedance matching and minimal signal reflection.

The VSWR of the simulated antenna is shown in Fig.4.

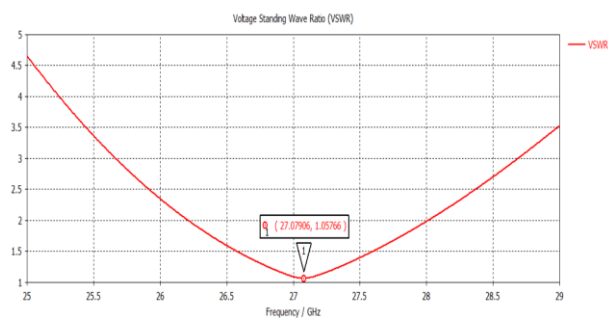

Fig. 4. VSWR of the designed antenna at 27 GHz

C. Gain and Directivity

Gain and directivity are important parameters that describe the radiation efficiency and directional performance of the antenna. The simulation results indicate that the antenna provides stable gain and directivity at the operating frequency, which is essential for reliable millimeter wave communication systems. The gain and directivity of the simulated antenna is shown in Fig.5.

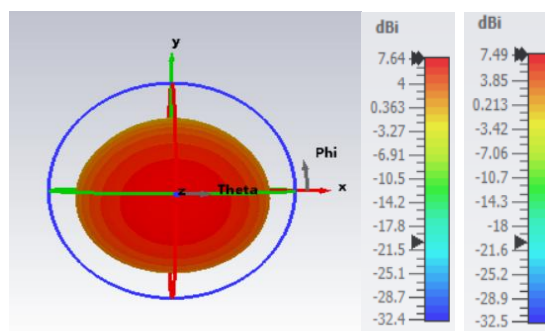

Fig. 5. Gain and Directivity of the designed antenna at 27 GHz

D. Radiation Pattern

The radiation pattern represents the directional distribution of radiated power from the antenna. The simulated radiation pattern demonstrates stable directional characteristics with effective radiation in the desired direction, making the antenna suitable for high-frequency wireless communication applications. The radiation pattern of the simulated antenna is shown in Fig.6.

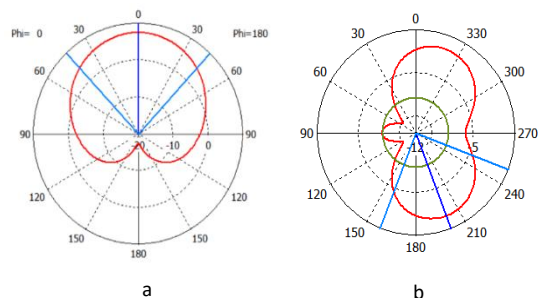

Fig. 6. Radiation Pattern of designed antenna (a) H plane (b) E plane

Simulation summary of the designed antenna are summarized in table II.

Table II. Simulation Summary of the Designed Antenna

Parameter	Simulated Value
Resonant Frequency	27 GHz
Return Loss (S11)	-31 dB
Bandwidth	1.711 GHz
Gain of the Designed Antenna	7.64 dBi
Voltage Standing Wave Ratio (VSWR)	1.057

IV. CONCLUSION

In this paper, a compact microstrip patch antenna operating at 27 GHz for millimeter wave communication applications has been presented. The antenna is designed on a Rogers RT/Duroid 5880 substrate with a dielectric constant of 2.2 and optimized dimensions to achieve efficient radiation performance. The proposed antenna structure provides stable electromagnetic characteristics while maintaining a compact size suitable for integration in high-frequency wireless devices.

Simulation results obtained using CST Studio Suite demonstrate that the antenna achieves good impedance matching at the desired operating frequency. The antenna exhibits a return loss of approximately -31 dB, a bandwidth of 1.711 GHz, a VSWR close to unity, and a gain of 7.64 dBi, indicating efficient radiation and minimal signal reflection.

The obtained performance characteristics confirm that the designed antenna is suitable for millimeter wave wireless communication systems, particularly for emerging high data rate applications. The compact structure and stable performance make the antenna a promising candidate for integration in future 5G and high-frequency communication devices.

REFERENCES

[1] Theodore S. Rappaport, S. Sun, R. Mayzus, H. Zhao, Y. Azar, K. Wang, G. N. Wong, J. K. Schulz, M. Samimi, and F. Gutierrez, "Millimeter Wave Mobile Communications for 5G Cellular: It Will Work," *IEEE Access*, vol. 1, pp. 335-349, 2013.

[2] J. J. Xu, Z. N. Chen, X. Qing, and W. Hong, "Millimeter-Wave Microstrip Patch Antenna for 5G Mobile Communication Systems," *IEEE Transactions on Antennas and Propagation*, vol. 65, no. 12, pp. 7287-7292, 2017.

[3] Z. Ullah Khan, S. F. Jilani, A. Belenguer, T. H. Loh, and A. Alomainy, "Empty Substrate Integrated Waveguide-Fed Millimeter-Wave Aperture-Coupled Patch Antenna for 5G Applications," 2018.

[4] H. Wang, D. Fang, and B. Zhang, "28 GHz Millimeter-Wave Rectangular Microstrip Patch Antenna for 5G Communication," *IEEE International Conference on Microwave and Millimeter Wave Technology*, 2020.

[5] C. A. Balanis, *Antenna Theory: Analysis and Design*, 4th ed. Hoboken, NJ, USA: Wiley, 2016.