

Internet of Things (IoT) & Sensor Networking For Smart Agriculture

Faheema Mohammed Baig

College Name:- Dr D Y Patil Arts, Commerce and Science College,
Pimpri Pune 411018

Abstract - he Internet of Things (IoT) is a technology where physical objects are connected to the internet so that they can collect, store and share data automatically. These objects are enabled with sensors, software, and network connectivity. When many sensors are connected together, they form a sensor network, which continuously gathers data and sends it to other systems for monitoring and helps in decision-making. This technology is now widely used in agriculture fields to increase the plants health and management resources. Plants in nurseries are often monitored manually and continuous manual monitoring is difficult and time-consuming with no real-time information which can lead to over-watering, under-watering, wastage of water and are very harmful to the plant's health. Hence, there is a need for an IoT based sensor networking system which can monitor the soil moisture, temperature and humidity and give real-time update and alerts the caretaker and automatically start the drip irrigation system. This sensors from a sensor network connected to a micro-controller that processes the data and can be easily monitored. It also minimizes human interference. Thus, the proposed system highlights how IoT and sensor networking can support smart and sustainable agriculture especially in nurseries.

Keywords:- Internet of Things, Sensor Networking, Smart Agriculture, Soil Monitoring, Real-Time Data

I. INTRODUCTION:-

Soil plays a very important role in agriculture and the plants health is mostly depends on soil .Its condition directly impacts the growth, yield and overall ecosystem. The plants need the right amount of water, temperature and humidity to grow properly. But in many nurseries water is supplied manually. This traditional method is not accurate and the plant faces problems like over-watering, under-watering, plant stress, and wastage of water. The caretaker also most of the time doesn't have real-time information about the plant's health. But with the development of modern technology, the Internet of Things (IoT) and sensor networking is helping to improve the agriculture sector. IoT allows different devices like sensors to connect and share real time information automatically. Sensor networks collect real-time data from the soil and environment

and send it to the user for monitoring. These technologies reduce human effort and human interference which helps in taking timely actions for better plant growth.

In nurseries caretakers often do not know what is the exact condition of the soil. Because of this, plants may not get water at the right time. To solve this problem, a smart monitoring system is required. An IoT-based system can continuously check soil moisture, temperature, and humidity and inform the user whenever attention is needed to the plant.

This research addresses these limitations by proposing a Soil Monitor which monitors the soil moisture environment conditions like temperature and humidity in real time and sends SMS and call alerts when the soil moisture goes below the specific threshold value and automatically drip irrigation will start. The main aim of this system is to reduce water usage, reduce manual work, and improve plant health through smart and automated monitoring.

II. SYSTEM ARCHITECTURE AND DESIGN

A. Mechanical design:-

This system consists of a compact and portable structure with sensors placed inside the plant roots for accurate monitoring. If the soil moisture goes below a specific threshold value, the system sends an SMS alert to the caretaker and drip irrigation will start automatically to maintain proper moisture level.

B. Hardware interfacing:-

1. Microcontroller Section:

Arduino Uno is used as a main controller that can process all sensor data and to control the system.

2. Sensor Interfacing

The soil moisture sensor is connected to the analog input pin of the arduino to measure the soil moisture

and the DHT11 sensor is connected to the digital pin to read temperature and humidity.

3. Communication Section:

The GSM module is interfaced with Arduino Uno through serial communication so that it can send SMS to the caretaker.

4. Control Section:

A relay module is connected to Arduino to automatically control the drip irrigation motor.

5. Power Supply:

All components are powered using regulated 5V and 12V supply for stable and safe operation.

III. Mathematical Modeling:-

The system reads soil moisture value from the sensor as an analog input. This value is then converted into percentage using the formula:

$$\text{Moisture \%} = (\text{Analog value} / 1023) * 100$$

A threshold(t) moisture value is set for proper plant growth. If the measured moisture value is less than the threshold, the system gives an alert signal. Temperature and humidity values are also monitored for better plant condition. Based on these parameters, the system decides whether irrigation should be ON or OFF. This mathematical logic helps to automate and smart decision making.

IV. BLOCK DIAGRAM:-

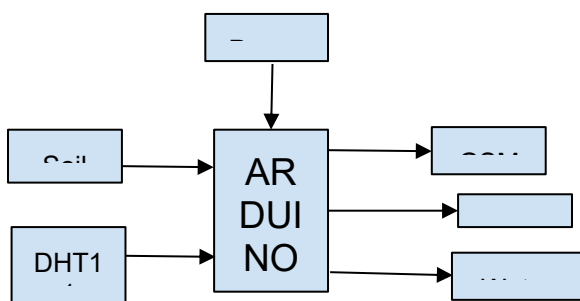

V. LITERATURE REVIEW:-

Limin Yu, Wanlin Gao, Redmond R. Shamshiri, Sha Tao, Yanzhao Ren, Yanjun Zhang, Guilian Su “A soil moisture sensor is an important tool for measuring soil moisture content. In this study, the previous research conducted in recent 2-3 decades on soil moisture sensors was reviewed and the principles of commonly used soil moisture sensors and their various applications were summarized.”[1]

Pushkar Singh; Sanghamitra Saikia “The designed system deals with various environmental factors such as moisture, temperature and amount of water required by the crops using sensors like water flow sensor, temperature sensor and soil moisture sensor. Data are collected and received by arduino which can be linked to an interactive website which shows the real time values along with the standard values of different factors required by a crop. This allows users to control irrigation pumps and sprinklers from far distances through a website and to meet the standard values which would help the farmer to yield maximum and quality crops.” [2]

Ravi Kishore Kodali; Archana Sahu “The influence of population growth on agriculture leads to a miserable impact on the farmers livelihood. To overcome the problems we design a low cost system for monitoring the agriculture farm which continuously measures the level of soil moisture of the plants and alerts the farmers if the moisture content of particular plants is low via sms or an email. This system uses an esp8266 microcontroller and a moisture sensor using the Losant platform.”[3]

VI. FUTURE SCOPE:-

1. The system can be connected to the internet using Wi-Fi so that it can be accessed from any remote places.
2. More sensors like pH level sensor and nutrient sensor can be added so that will be beneficial for the plant.
3. Data can be stored on cloud platforms for long-term monitoring and to have a previous record of the plant.
4. Automatic weather-sensors for irrigation control can be added.
5. The system can be used in large agricultural areas.

VII. CONCLUSION:-

This system demonstrates the effective use of IoT and sensor networking in agriculture and in nursery for the plant monitoring. The system continuously measures important parameters such as soil moisture, temperature, and humidity in

real time. By providing accurate and timely information, it helps caretakers to understand the raw condition of plants without the need for manual checking., That can reduce human interference and also saves time. Whenever the soil moisture level goes below the specific threshold value, the system immediately sends an SMS alert and automatically the drip irrigation system will start. This ensures that the plants receive water at the right time and in the right amount. The system reduces human effort, prevents water wastage, and improves overall plant health. It is simple to use, low-cost, and suitable for small-scale agricultural fields, home gardens, and college campuses. The project proves that traditional farming methods can be improved with modern technology. Overall, this system shows us that IoT-based smart monitoring systems are practical, reliable, and helpful for getting efficient and sustainable agriculture.

VIII. REFERENCES:-

- [1] Limin Yu, Wanlin Gao, Redmond R. Shamshiri, Sha Tao, Yanzhao Ren, Yanjun Zhang, Guilian Su. Review of research progress on soil moisture sensor technology[J]. International Journal of Agricultural and Biological Engineering, 2021, 14(4): 32-42. DOI: 10.25165/j.ijabe.20211404.6404
- [2] Pushkar Singh; Sanghamitra Saikia “Arduino-based smart irrigation using water flow sensor, soil moisture sensor, temperature sensor and ESP8266 WiFi module” 2016 IEEE Region 10 Humanitarian Technology Conference (R10-HTC) DOI: 10.1109/R10-HTC.2016.7906792
- [3] Ravi Kishore Kodali; Archana Sahu “An IoT based soil moisture monitoring on Losant platform” 2016 2nd International Conference on Contemporary Computing and Informatics (IC3I)